

# LinkSwitch<sup>®</sup>

## Design Guide

### Application Note AN-35



## Introduction

Integrated switching power supply technology, offering small size, low weight and universal AC input voltage operation, has finally evolved to cost-effectively replace linear transformer-based power supplies for low power applications. *LinkSwitch* reduces the cost of switching battery chargers and AC adapters to the level of linear transformer power supplies. *LinkSwitch* also easily meets standby and no-load energy consumption guidelines specified by worldwide regulatory programs such as the USA's Presidential 1 W Standby Executive Order and the European Commission's 2005 requirement for 300 mW no-load consumption.

The feature set of *LinkSwitch* offers the following advantages over other solutions:

- Lowest cost and component count for a constant voltage, constant current (CV/CC) solution
- Extremely simple circuit – only 14 components required for a production-worthy design
- Primary based CV/CC solution eliminates 10 to 20 components for low system cost
- Up to 75% lighter power supply reduces shipping costs
- Fully integrated auto-restart for short circuit and open loop fault protection
- 42 kHz operation simplifies EMI filter design
- 3 W output with EE13 core for low cost and small size

*LinkSwitch* is designed to produce an approximate CV/CC

output characteristic as shown in Figure 2. In charger applications, a discharged battery operates on the CC portion of the curve until almost fully charged and then naturally transitions to the CV portion of the curve. Below an output voltage of approximately 2 V (consistent with a failed battery pack), the supply enters auto-restart, reducing the average output current to approximately 8% of nominal.

In an AC adapter, normal operation occurs only on the CV portion of the curve, the CC portion providing overload protection and auto-restart short circuit protection.

*LinkSwitch* is a fixed frequency PWM controlled device, designed to operate with flyback converters in discontinuous mode. In the CV portion of the curve, the device operates using voltage mode control and changes to a current limit mode during the CC portion of the curve. Total system CV accuracy is typically  $\pm 10\%$  at the peak power point, including all device tolerances and line input voltage variations. The total system CC accuracy is typically  $\pm 20\%$  (LNK501),  $\pm 25\%$  (LNK500) and  $\pm 24\%$  (LNK520).

During CV operation, the output voltage is sensed on the primary side and controls the duty cycle. For LNK500/501 the device is placed in the high-side rail as shown in Figure 1. This allows the reflected output voltage ( $V_{OR}$ ) to be sensed directly, requiring no additional subtraction of the input voltage component. For LNK520, the device is placed in the low-side as shown in Appendix B, Figure B1, with an auxiliary/bias winding to sense the output voltage.

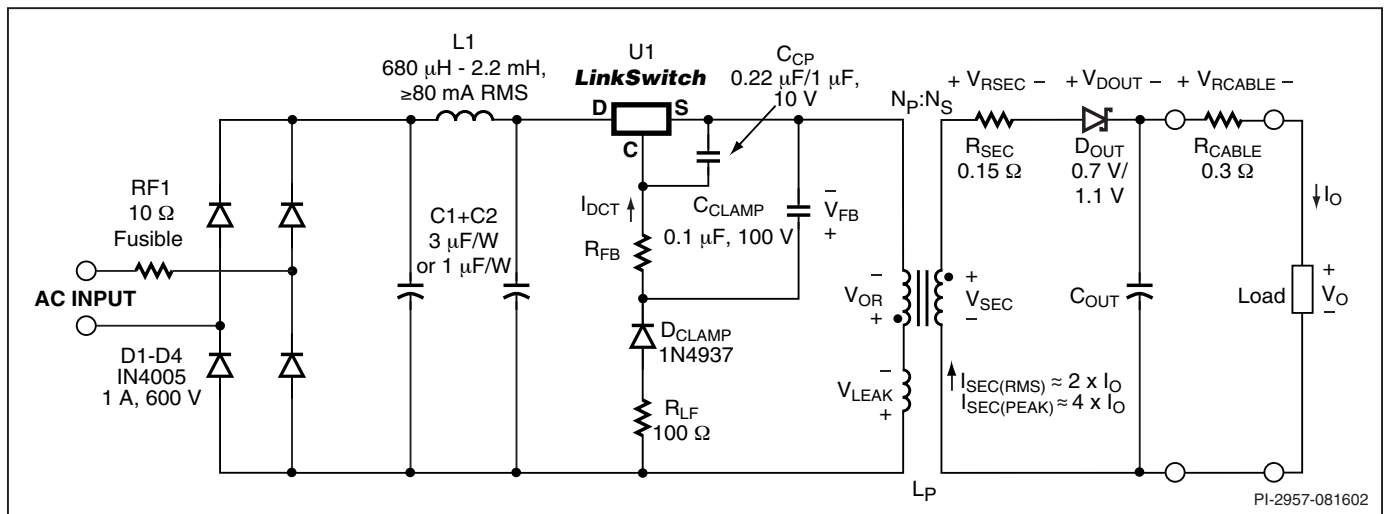

Figure 1. Key Parameters for an Initial LinkSwitch Design.

During CC operation, duty cycle is controlled by the peak drain current limit ( $I_{LIM}$ ). The device current limit is designed to be a function of reflected voltage such that the load current remains approximately constant as the load impedance is reduced. When the output voltage falls to approximately 30% of nominal value (normally associated with a failed battery), *LinkSwitch* enters the auto-restart mode of operation to safely limit average fault current (typically 8% of  $I_O$ ).

With discontinuous mode design, maximum output power is independent of input voltage and is a simple function of primary inductance, peak primary current squared and switching frequency (Equation 6). *LinkSwitch* controls and cancels out variations normally associated with frequency and peak current by specifying a device  $I^2t$  term. This allows users to easily design for a specific corner point where CV mode transitions to CC mode.

## Scope

This application note is for engineers designing an AC-DC power supply using the *LinkSwitch* LNK500/501 or LNK520 devices in a discontinuous mode flyback converter. The main document focuses on the LNK500/501 devices. However, as much of the information is also applicable to LNK520, it is recommended this section be read regardless of the device selected for the design. For a detailed comparison of LNK500 vs. LNK520 please see Table B2. Appendix A provides a detailed tolerance analysis for LNK500/501 designs while Appendix B provides specific guidance when designing with LNK520 devices.

Since *LinkSwitch* is designed to replace linear transformer based power supplies, the output characteristic provides an approximate CV characteristic, offering much better line and load regulation than an equivalent linear transformer. The very simple nature of the *LinkSwitch* circuit allows an initial paper design to be completed quickly using simple design equations. It is then recommended that the circuit performance be tuned with a prototype power supply to finalize external component choices.

This document therefore highlights the key design parameters and provides expressions to calculate the transformer turns ratio, primary inductance and clamp/feedback component values. This enables designers to build an operating prototype and iterate to reach the final design.

For readers who want to generate a design as quickly as possible, the Quick Start tables (Table 1 for LNK500/501 and Table B1 for LNK520) provide enough information to generate an initial prototype.

This document does not address transformer construction. Please see *LinkSwitch* DAK Engineering Prototype Reports for

## LNK500/501 QUICK START

Figure 1 shows the key parameters and components needed to generate an initial *LinkSwitch* design. Where initial estimates can be used, they are shown below the parameter they refer to.

- 1) Let  $V_{OR}$  equal 50 V.
- 2) Define the transformer turns ratio according to Equation 5. If no better estimates or measurements are available, then let  $V_{DOUT}$  equal 0.7 V for a Schottky or 1.1 V for a PN diode,  $R_{CABLE}$  equal  $0.3 \Omega$ ,  $R_{SEC}$  equal  $0.15 \Omega$ ,  $I_{SEC(RMS)}$  equal  $2 \times I_O$ , and  $I_{SEC(PEAK)}$  equal  $4 \times I_O$ , where  $I_O$  is the desired CC output current and  $V_O$  is the desired output voltage at the CV/CC transition point.
- 3) Calculate  $P_{O(EFF)}$  according to Equation 13. As an initial estimate for  $P_{CORE}$  use 0.1 W.
- 4) Calculate  $L_p$  according to Equation 14 and other transformer parameters from Equations 15, 16, 17, 18 and 19.
- 5) Calculate value for feedback resistor  $R_{FB}$  according to Equations 20, 21, 22, 23 and 24. This should be a 1/4 W, 1% part.
- 6) Set clamp capacitor  $C_{CLAMP}$  as a 0.1  $\mu F$ , 100 V metalized plastic film type.
- 7) Set clamp resistor  $R_{LF}$  as 100  $\Omega$ , 1/4 W.
- 8) Set CONTROL pin capacitor  $C_{CP}$  to be 0.22  $\mu F$ , 10 V for battery loads or 1  $\mu F$ , 10 V for resistive loads.
- 9) Select input and output components. See Figure 3 and relevant sections.
- 10) Construct prototype.
- 11) Iterate design (see Hints and Tips section).

Table 1. LNK500/501 Quick Start.

examples showing typical transformer construction techniques. Further details of support tools and updates to this document can be found at [www.powerint.com](http://www.powerint.com).

## CV/CC Circuit Design

The *LinkSwitch* circuit shown in Figure 3 serves as a CV/CC charger example to illustrate design techniques. Nominal output voltage is 5.5 V and nominal CC output current is 500 mA.



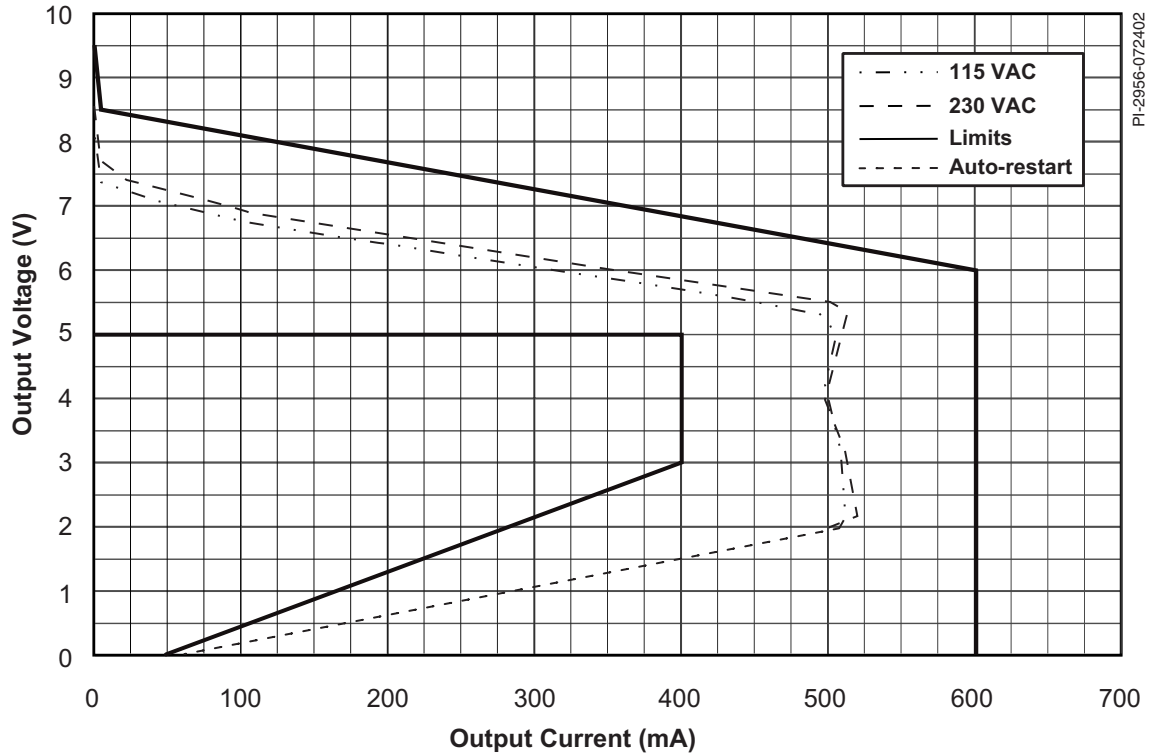

Figure 2. Typical Output Characteristic for LinkSwitch LNK500/501 Based 5.5 V, 0.5 A Charger with Specification Limits.

*LinkSwitch* design methodology is very simple. Transformer turns ratios and bias component values are selected at the nominal peak power point output voltage  $V_O$ , while transformer primary inductance is calculated from the total output power. Few components require computations, while the balance are selected from the included recommendations.

Design and selection criteria for each component are described starting with the transformer. Once set, transformer parameters and behavior are used to design clamp, bias and feedback components for proper supply operation. Output capacitors and the input circuitry can then be determined.

### Transformer T1

Transformer design begins by selecting the reflected output voltage ( $V_{OR}$ ). For most *LinkSwitch* designs,  $V_{OR}$  should be between 40 V and 60 V. A good starting point is 50 V allowing for optimization later.

$V_{OR}$  values over 60 V are recommended only for those applications allowed to consume over 300 mW at no-load.

To calculate the transformer turns ratio, the voltage required across the secondary winding  $V_{SEC}$  is first calculated. This is a function of output cable voltage drop  $V_{RCABLE}$ , nominal output

voltage  $V_O$ , the secondary winding voltage drop  $V_{RSEC}$ , and output diode forward voltage drop  $V_{DOUT}$ . Figure 1 shows the sources of secondary side voltage drops. Since  $C_{CLAMP}$  charges to the peak value of  $V_{OR}$  plus an error due to leakage inductance, the value of  $V_{RSEC}$  and  $V_{DOUT}$  are defined at the peak secondary current. The output cable drop  $V_{RCABLE}$  is defined at the nominal CC output current  $I_O$ .

Curves of  $V_{DOUT}$  versus instantaneous current can be found in the diode manufacturer's data sheet. Peak secondary current is defined as:

$$I_{SEC(PEAK)} = I_{PRI(PEAK)} \times \frac{N_P}{N_S} \quad (1)$$

The value for  $I_{PRI(PEAK)}$  is equal to the typical value of the *LinkSwitch* data sheet parameter  $I_{LIM}$ .

As an initial estimate the  $I_{SEC(PEAK)}$  can be approximated as  $4 \times I_O$ . Once the first prototype has been built this can be refined as the final turns ratio is known or alternatively, the peak diode forward voltage can be measured directly using an oscilloscope.

$$V_{RCABLE} = I_O \times R_{CABLE} \quad (2)$$

$$V_{RSEC} = I_{SEC(PEAK)} \times R_{SEC} \quad (3)$$

$$V_{SEC} = V_O + V_{RCABLE} + V_{DOUT} + V_{RSEC} \quad (4)$$

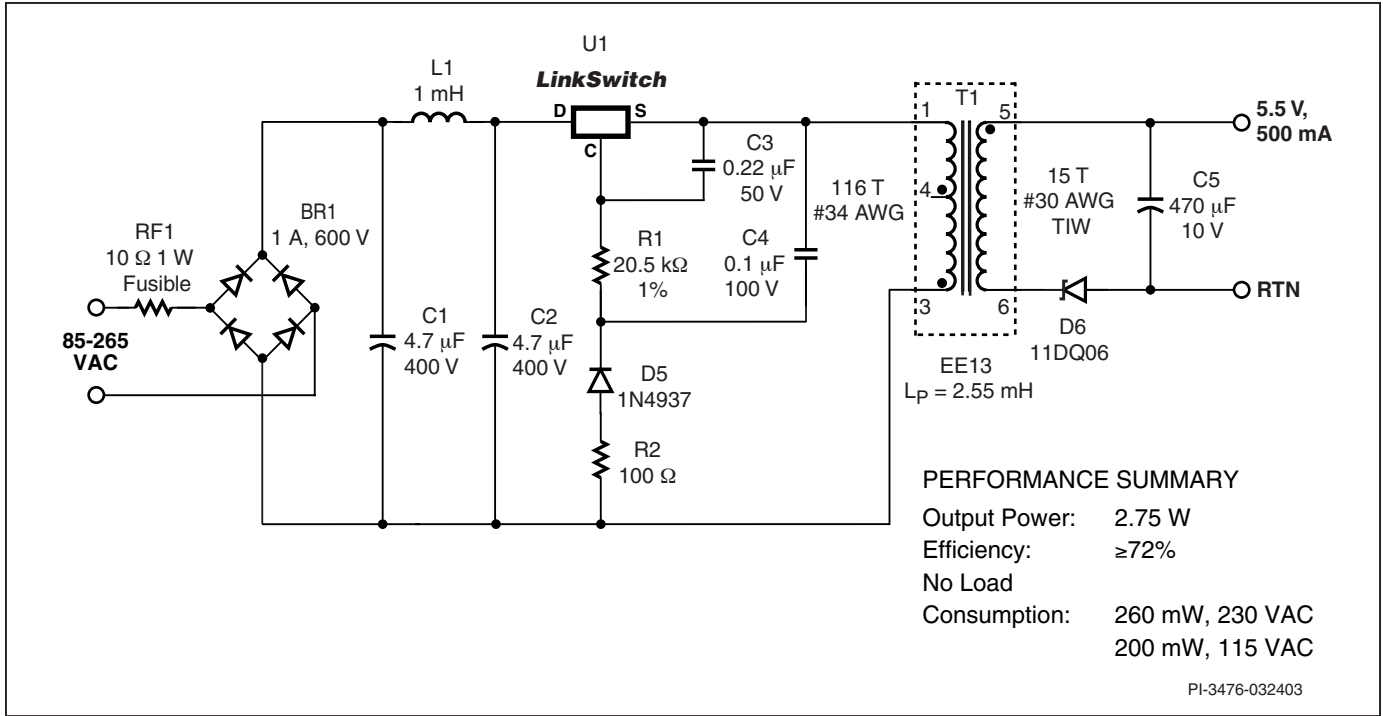

Figure 3. Example Schematic for a Typical LinkSwitch Charger.

The transformer turns ratio is given by:

$$\frac{N_P}{N_S} = \frac{V_{OR}}{V_{SEC}} \quad (5)$$

If no better estimates or measurements are available, use 0.15 Ω as an initial value for the transformer secondary winding resistance  $R_{SEC}$ , 0.7 V for the forward voltage ( $V_{DOUT}$ ) of a Schottky diode or 1.1 V for a PN diode and 0.3 Ω for the cable resistance  $R_{CABLE}$ .

The next transformer design step is to calculate the nominal primary inductance  $L_P$ .  $L_P$  tolerance should be within ±10% (to meet peak power CC tolerance of ±20% for LNK501, ±25% for LNK500). The simple LinkSwitch feedback circuit is designed specifically for discontinuous mode operation. Continuous mode designs result in control loop instability and are therefore not recommended. For proper CC operation, the LinkSwitch transformer must therefore be designed for discontinuous operation under all line/load conditions.

At the peak power point, the power processed by the core or  $P_{O(EFF)}$  is given by:

$$P_{O(EFF)} = \frac{1}{2} \times L_P \times \left[ I_P^2 \times f_S \right] \quad (6)$$

$L_P$  is the nominal transformer primary inductance,  $I_P$  is equal to the LinkSwitch parameter  $I_{LIM}$  and  $f_S$  is the switching frequency.

Note that  $I_P$  and  $f_S$  are enclosed in brackets as the LinkSwitch data sheet specifies an  $I_P f_S$  product, normalized to  $I_{DCT}$ . By normalizing to  $I_{DCT}$  (the CONTROL pin current at 30% duty cycle), the effect of  $I_{DCT}$  tolerance is included and does not need to be considered separately. Output power is therefore dependent primarily on transformer primary inductance tolerance (typically ±10% for low cost high volume production methods).

As shown above, effective output power  $P_{O(EFF)}$  is calculated from the total energy stored in the transformer and is therefore the sum of actual output power  $P_O$  and the following loss terms: cable power  $P_{CABLE}$ , diode power  $P_{DIODE}$ , bias power  $P_{BIAS}$  (the power required to drive the LinkSwitch CONTROL pin), transformer secondary copper loss  $P_{S(CU)}$ , and transformer core loss  $P_{CORE}$ .

$$P_{CABLE} = R_{CABLE} \times I_O^2 \quad (7)$$

$$P_{DIODE} = V_{DOUT} \times I_O \quad (8)$$

$$P_{BIAS} = V_{OR} \times 2.3 \text{ mA} \quad (9)$$

$$P_{CORE} = \frac{K_{CORE} \times V_E}{2} \quad (10)$$

$$P_{S(CU)} = I_{SEC(RMS)}^2 \times R_{SEC} \quad (11)$$

$R_{CABLE}$  is the total cable DC resistance,  $I_O$  is the nominal CC output current,  $V_{DOUT}$  is output diode forward voltage drop,  $V_{OR}$  is reflected output voltage,  $I_{SEC(RMS)}$  is secondary RMS current,



$R_{SEC}$  is output winding DC resistance,  $V_E$  is core effective volume and  $K_{CORE}$  is core loss per unit volume. As before, if no better estimates or measurements are available, use  $0.15 \Omega$  for  $R_{SEC}$ ,  $0.7 V$  for the forward voltage ( $V_{DOUT}$ ) of a Schottky diode or  $1.1 V$  for a PN diode,  $0.3 \Omega$  for  $R_{CABLE}$  and  $I_{SEC(PEAK)}$  equal to  $4 \times I_O$ . Both  $V_E$  and  $K_{CORE}$  can be read from the ferrite core manufacturer's material curves. To find  $K_{CORE}$ , use the core flux swing  $B_M$ . In discontinuous mode operation, AC Flux Density  $B_{AC}$  is equal to  $B_M$ :

$$B_{AC} = B_M \quad (12)$$

The division by two in the expression for  $P_{CORE}$  is required since a flyback transformer only excites the core asymmetrically and the core loss curves are typically specified assuming a symmetrical excitation.

$K_{CORE}$  is then read directly from material core loss curves at the *LinkSwitch* switching frequency (typically 42 kHz). A figure for  $B_M$  of approximately 3300 gauss (330 mT) is a good initial estimate. A figure for  $P_{CORE}$  of 0.1 W is a good initial estimate.

$P_{O(EFF)}$  is calculated from:

$$P_{O(EFF)} = P_O + P_{CABLE} + P_{DIODE} + P_{BIAS} + P_{S(CU)} + \frac{P_{CORE}}{2} \quad (13)$$

$P_O$  here is defined as the output power seen by the load. Note the core loss term is divided in half as only the loss associated with transferring energy to the output during the off time needs to be compensated for in the primary inductance value.

Nominal primary inductance  $L_{P(NOM)}$  is calculated from:

$$L_{P(NOM)} = \frac{2 \times P_{O(EFF)}}{\left[ I_P^2 \times f_s \right]} \times \Delta_L \quad (14)$$

The typical data sheet value for the  $Pf_s$  coefficient should be used to replace  $Pf_s$ , this defining the nominal primary inductance at the nominal output peak power point.

As the flux density increases, the inductance falls slightly due to the BH characteristic of the core material as shown in Figure 4. This drop in inductance is compensated by increasing the inductance at zero flux density by a factor  $\Delta_L$ . This is typically in the range of 1 to 1.05 for common low cost ferrite materials. This effect can be minimized by increasing the gap size, reducing the flux density or using ferrite materials with a higher saturation flux density.

Transformer inductance tolerance is most affected by the transformer core gap length. Inductance must also be stable over temperature and as a function of current. Recommended

minimum gap length is 0.08 mm (3.2 mils) at a peak flux density of 3300 gauss to 3500 gauss (330 mT to 350 mT).

The number of secondary turns for small E cores is typically 2 to 3 turns per volt across the secondary winding (including cable, secondary and diode voltage drops). The actual number is adjusted to meet gap size and flux density limits.

Once an estimate for the number of secondary turns  $N_S$  has been made, the primary turns is found from:

$$N_P = \frac{V_{OR}}{V_{SEC}} \times N_S \quad (15)$$

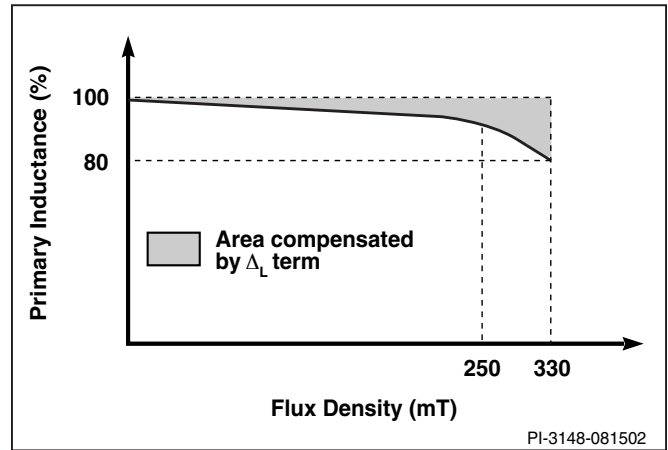

Figure 4. Typical Reduction in Primary Inductance with Flux Density for Small E Cores with Small Gap Sizes.

At this point the core size should be selected. Common core sizes suitable for a *LinkSwitch* design include EE13, EF12.6, EE16 and EF16. With the core selected and the number of transformer turns known, the core peak flux density  $B_p$  (gauss) can be found using the effective cross sectional area of the core  $A_e$  (cm<sup>2</sup>), the primary inductance ( $\mu H$ ) and the *LinkSwitch* peak current limit  $I_{LIM(MAX)}$  (A):

$$B_p = \frac{100 \times I_{LIM(MAX)} \times L_P}{N_P \times A_e} \quad (16)$$

$B_p$  should be in the range of 3000 gauss to 3500 gauss (300 mT to 350 mT).

The relative permeability  $\mu_r$  of the ungapped core must be calculated to estimate the gap length  $L_g$ . The relative permeability,  $\mu_r$  is found from core parameters  $A_e$  (cm<sup>2</sup>), the effective core path length  $L_e$  (cm), and ungapped effective inductance  $A_L$  (nH/t<sup>2</sup>):

$$\mu_r = \frac{A_L \times L_e}{0.4 \times \pi \times A_e \times 10} \quad (17)$$



Gap length  $L_g$  is the air gap ground into the center leg of the transformer core. Grinding tolerances and  $A_L$  accuracy place a minimum limit of approximately 0.08 mm on  $L_g$ . If  $L_g$  is smaller than this then either the core size ( $A_c$ ) or  $N_p$  must be increased.  $L_g$  (mm) is calculated from primary turns  $N_p$ , core effective cross sectional area  $A_c$  (cm<sup>2</sup>), primary inductance  $L_p$  (μH), core effective path length  $L_c$  (cm) and relative permeability  $\mu_r$ :

$$L_g = \left[ \frac{0.4 \times \pi \times N_p^2 \times A_c}{L_p \times 100} - \frac{L_c}{\mu_r} \right] \times 10 \quad (18)$$

The gapped effective inductance  $A_{LG}$  (nH/t<sup>2</sup>), required by the transformer manufacturer, is calculated from the primary inductance  $L_p$  (μH) and the number of primary turns  $N_p$ :

$$A_{LG} = 1000 \times \frac{L_p}{N_p^2} \quad (19)$$

### Clamp, Bias, Bypass and Feedback

An RCD clamp, formed by  $R_{FB}$ ,  $C_{CLAMP}$ , and  $D_{CLAMP}$  (Figure 1), safely limits transformer primary voltage, due to transformer leakage inductance, to below the *LinkSwitch* internal MOSFET breakdown voltage  $BV_{DSS}$  each time *LinkSwitch* turns off. Leading-edge voltage spikes (caused by transformer leakage inductance) are filtered by  $R_{LF}$  and  $C_{CLAMP}$ , such that  $C_{CLAMP}$  effectively charges to the transformer reflected voltage.

Feedback is derived from the reflected voltage, that approximates closely the transformer secondary winding output voltage ( $V_{SEC}$  in Figure 1) multiplied by the transformer turns ratio. Due to effects of leakage inductance (causing peak charging), calculated  $V_{OR}$  may be slightly different from actual voltage measured across  $C_{CLAMP}$ . Since *LinkSwitch* is in the upper rail, reflected voltage information is now relative to the *LinkSwitch* SOURCE pin and independent of the input voltage.

Reflected voltage is directly converted by  $R_{FB}$  to *LinkSwitch* CONTROL pin current for duty cycle control and bias. The CONTROL pin capacitor  $C_{CP}$  provides bypass filtering, control loop compensation, and the energy storage required during start-up and auto-restart.

### Feedback Resistor ( $R_{FB}$ )

Clamp and feedback circuit design begins by first considering reflected voltage. Using the schematic in Figure 3 as an example. With primary turns  $N_p = 116$  and secondary turns  $N_s = 15$  the peak secondary current can be calculated from Equation 20, where  $I_{PRI(PEAK)}$  is equal to the *LinkSwitch* typical current limit  $I_{LIM(TYP)}$ .

$$\begin{aligned} I_{SEC(PEAK)} &= \frac{N_p}{N_s} \times I_{PRI(PEAK)} \\ &= \frac{116}{15} \times 0.254 \\ &= 1.96 \text{ A} \end{aligned} \quad (20)$$

The secondary diode peak voltage was measured as 0.7 V, the secondary winding resistance as 0.15 Ω and the cable resistance as 0.23 Ω. Therefore  $V_{SEC}$  is defined as:

$$\begin{aligned} V_{SEC} &= V_O + V_{RCABLE} + V_{DOUT} + V_{RSEC} \\ &= V_O + (I_O \times R_{CABLE}) + V_{DOUT} \\ &\quad + (I_{SEC(PEAK)} \times R_{RSEC}) \\ &= 5.5 \text{ V} + (0.5 \text{ A} \times 0.23 \Omega) + 0.7 \text{ V} \\ &\quad + (1.96 \text{ A} \times 0.15 \Omega) \\ &= 6.61 \text{ V} \end{aligned} \quad (21)$$

Voltage  $V_{SEC}$  allows the exact  $V_{OR}$  to be calculated:

$$\begin{aligned} V_{OR} &= \frac{N_p}{N_s} \times V_{SEC} \\ &= \frac{116}{15} \times 6.61 \text{ V} \\ &= 51.1 \text{ V} \end{aligned} \quad (22)$$

Resistor  $R_{FB}$ , a 1%, 0.25 W resistor, converts clamp voltage to *LinkSwitch* bias and control current.

Feedback voltage  $V_{FB}$  is calculated from  $V_{OR}$  and the error due to leakage inductance,  $V_{LEAK}$ .

The value for  $V_{LEAK}$  varies depending on the value of leakage inductance, the size of the clamp capacitor and the type of clamp diode selected. For a leakage inductance of 50 μH, a value of 5 V is a good initial estimate.

$$V_{FB} = V_{OR} + V_{LEAK} \quad (23)$$

Once a prototype has been constructed, the value of  $V_{FB}$  can be found directly, by measuring the voltage across  $C_{CLAMP}$  at the power supply peak output power point, using a battery powered digital voltmeter. These have sufficient common mode rejection to be unaffected by the switching waveform and provide accurate results. The voltage measured is  $V_{FB}$ . By subtracting  $V_{OR}$  the value for  $V_{LEAK}$  can be determined, useful as an estimate in future designs. For the design in Figure 3,  $V_{FB}$  was measured as 56.7 V, giving  $V_{LEAK}$  as 5.6 V.



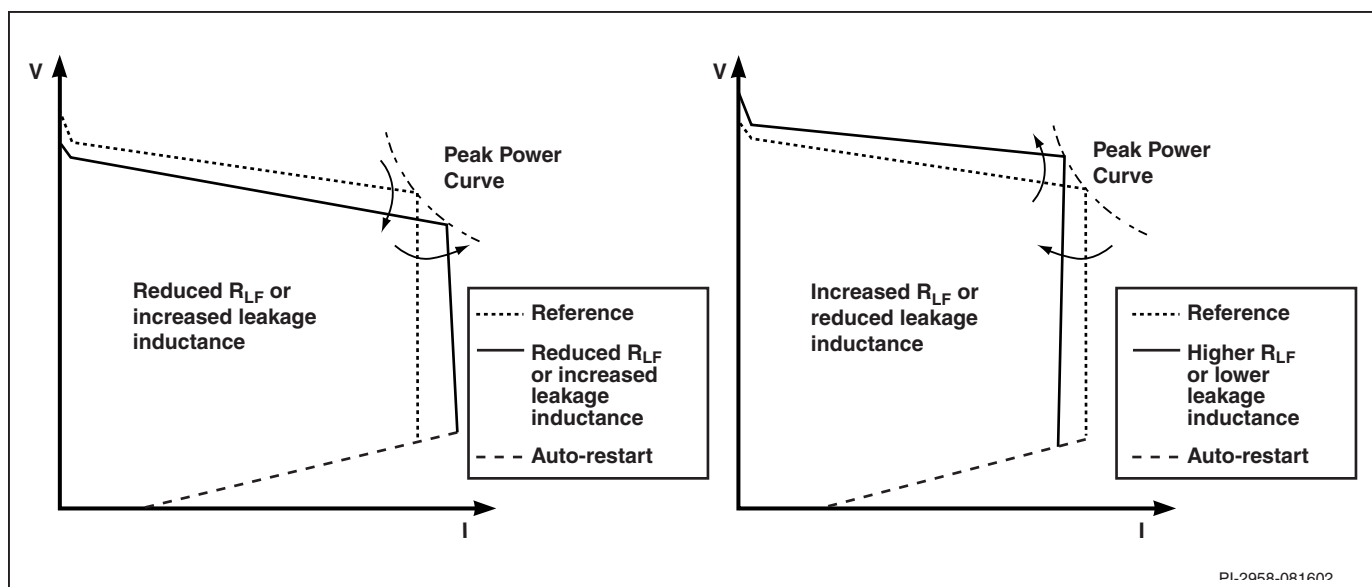

Figure 5. Effect on Output Characteristic when  $R_{LF}$  or Leakage Inductance Changes.

An initial value for  $R_{FB}$  is calculated from the feedback voltage  $V_{FB}$ , the CONTROL pin voltage  $V_{C(IDCT)}$  and current  $I_{DCT}$  at the CC/CV transition point, specified in the *LinkSwitch* data sheet.

$$\begin{aligned} R_{FB} &= \frac{V_{FB} - V_{C(IDCT)}}{I_{DCT}} \\ &= \frac{56.7 \text{ V} - 5.75 \text{ V}}{2.3 \text{ mA}} \\ &= 22 \text{ k}\Omega \end{aligned} \quad (24)$$

Select the nearest standard value. Resistor  $R_{FB}$  can then be adjusted to center the output voltage. The example in Figure 3 uses a 20.5 k $\Omega$  value for  $R_{FB}$  (R1), centering the output voltage  $V_o$  near 5.5 V at nominal output current  $I_o$ .

Note that  $R_{FB}$  power dissipation, a significant component of *LinkSwitch* standby power, should always be calculated:

$$P_{RFB} = (2.3 \text{ mA})^2 \times R_{FB} = 111 \text{ mW} \quad (25)$$

For applications that do not need to comply with strict standby power requirements, higher values of  $V_{OR}$  can be used, also increasing the power capability of *LinkSwitch*.

### Clamp Diode ( $D_{CLAMP}$ )

Diode  $D_{CLAMP}$  should be an ultra-fast or fast recovery diode with at least 600 V breakdown voltage. Fast types typically offer a slight cost advantage and also reduce EMI, so they are preferred.

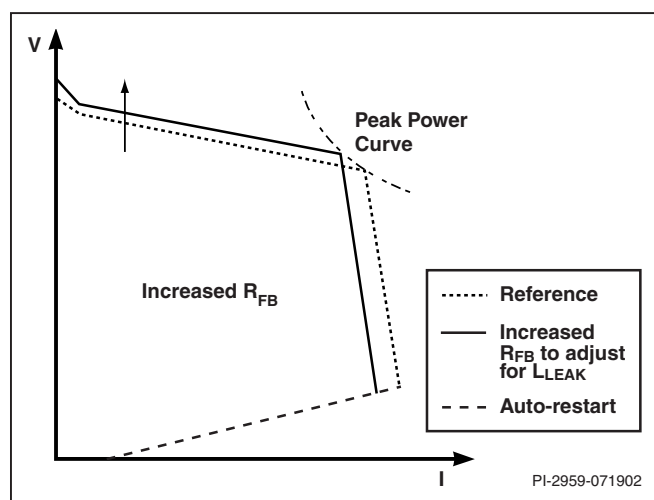

Figure 6. Increasing  $R_{FB}$  to Adjust for High Leakage Increases No-Load Voltage and Consumption.

Note that normal recovery diodes (1N400X or similar types), which may allow excessive drain voltage ringing, should not be used.

### Clamp Resistor ( $R_{LF}$ )

The value for  $R_{LF}$ , which effectively filters the leakage inductance spike from the reflected voltage waveform, is verified empirically through iteration.  $R_{LF}$  has a direct effect on both the average value and slope of both the CV and CC curves as shown in Figure 5 and can therefore be used to tune the output characteristic to some extent.

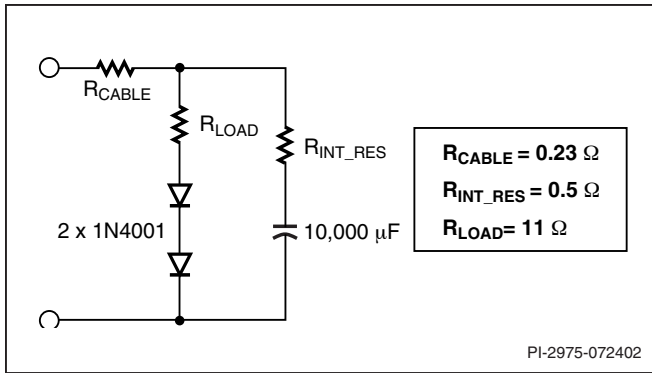

Figure 7. Example of Battery Model Load (Values for a Typical 3 W, 5.5 V Battery Charger).

In the CV region, increasing  $R_{LF}$  increases the average output voltage, while reducing the slope of the CV region (the change in output voltage with the change in output current). In the CC region, increasing  $R_{LF}$  makes the average output current lower, while tending to “bend” the curve inward slightly (fold back).

At no-load, increasing  $R_{LF}$  slightly increases the no-load voltage since the primary leakage inductance is filtered more effectively, but the same peak charging due to secondary leakage inductance occurs. Although the no-load voltage is slightly higher, there is only a minor effect on no-load consumption.

In a design that has high leakage, the value of  $R_{FB}$  can be increased to raise the overall output voltage (Figure 6). However, this will also increase no-load voltage and therefore no-load input power consumption.

To iterate  $R_{LF}$ :

- Start with typical value of 100  $\Omega$  and a transformer with nominal inductance.
- Verify CC portion of the curve and increase or decrease  $R_{LF}$  until CC curve is approximately vertical (current at start of CC and end are approximately the same)
- Verify CV portion of the curve.
  - For minor adjustment, change value of  $R_{FB}$ .

### Clamp Capacitor ( $C_{CLAMP}$ )

With small values of clamp capacitor  $C_{CLAMP}$ , the output voltage tends to be slightly higher. With larger values for  $C_{CLAMP}$ , output voltage will be slightly lower. Further increases in  $C_{CLAMP}$  will not change the output voltage.

$C_{CLAMP}$  is therefore chosen empirically as the smallest value that does not significantly change the output voltage when compared to the next larger value. For most designs, 100 nF is typical and standard device tolerances will have a negligible effect on the output voltage. This capacitor should be rated above the  $V_{OR}$ , typically 100 V.

$C_{CLAMP}$  must have a stable value over temperature and also over the operating voltage range. Metalized plastic film capacitors are the best choice, since the higher voltage ceramic capacitors with stable dielectrics (NPO or COG, for example) are higher cost. The value of low cost ceramic capacitors varies significantly with voltage and temperature (Z5U dielectric, for example) and should not be used since they may cause output oscillation.

### CONTROL Pin Capacitor ( $C_{CP}$ )

$C_{CP}$  sets the auto-restart period and also the time the output has to reach regulation before entering auto-restart at power supply start-up. If the load is a battery, then a value of 0.22  $\mu$ F is typical. However, if the supply is required to start into a resistive load or constant current load (such as a bench electronic load) at the peak output power point, then this should be increased to 1  $\mu$ F. This ensures enough time during start-up to bring the output into regulation. The type of capacitor is not critical. Either a small ceramic or electrolytic may be used with a voltage rating of 10 V or more.

### Output Rectifier and Filter ( $D_{OUT}$ , $C_{OUT}$ )

The output diode should be selected with an adequate peak inverse voltage (PIV) rating. Either PN or Schottky diodes can be used. Schottky diodes offer higher efficiency at higher cost but provide the most linear CC output characteristic. Both fast or ultra fast PN diodes may be used, but ultra fast ( $t_{rr} \sim 50$  ns) are preferred giving CC linearity close to the performance of a Schottky.

$$PIV D_{OUT} \geq \left( V_{DC(MAX)} \times \frac{N_S}{N_P} \right) + (V_O \times 1.5) \quad (26)$$

The output diode voltage rating should be calculated from Equation 26.  $V_{DC(MAX)}$  is the maximum primary DC rail voltage (375 V for universal or 230 VAC and 187 V for 115 VAC only designs). The output voltage  $V_O$  is multiplied by 1.5 to allow for increased output voltage at no-load. An output diode current rating of  $2 \times I_O$  is a good initial estimate.

The output diode may be placed in either the upper or lower leg of the secondary winding. However, placement in the lower leg may provide lower conducted EMI with a suitably constructed transformer.

For battery charger applications, the size and cost of the output capacitor  $C_{OUT}$  can be significantly reduced. High ripple current flows through  $C_{OUT}$  for only the short time a fully depleted battery charges. The designer should take into account that  $C_{OUT}$  ripple current rating can be exceeded for short periods of time without reducing lifetime significantly. When the battery is close to fully charged, the *LinkSwitch* circuit transitions to CV mode, where capacitor ripple current is much smaller.

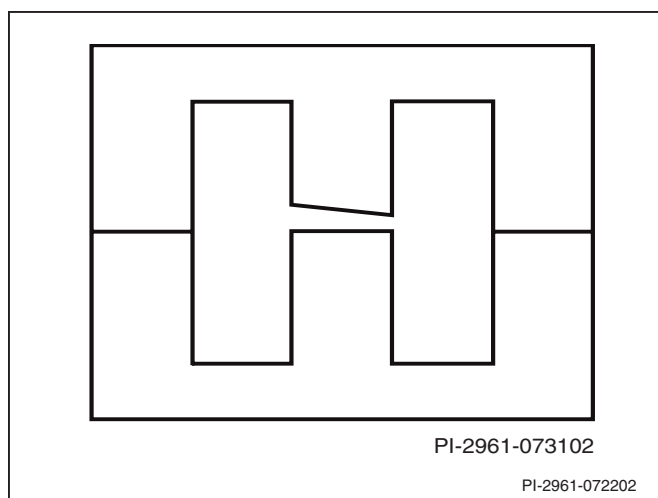

Figure 8. Uneven Core Gapping Makes CC Portion Nonlinear and Should be Avoided.

For adapter applications drawing rated load current in steady state,  $C_{OUT}$  should be a low ESR type, properly rated for ripple current.

Designs for battery charging usually do not require an additional output L-C stage ( $\pi$  filter) to reduce switching noise. The battery itself will filter this noise and output ripple. However, if the load is resistive, then this stage may be required to meet ripple and noise specifications. For evaluation of a battery charger during design, a battery load can be simulated using a circuit similar to that shown in Figure 7, which models both the battery and output cable.

### Bridge Rectifier, Energy Storage, and EMI Filter

Figure 1 shows a typical input stage for a low cost design. D1-D4 rectifies universal AC input voltage. C1 and C2 provide energy storage, smoothing, and EMI filtering. RF1 reduces surge current, EMI and will also safely open, like a fuse, if another primary component fails in a short circuit.

The conducted emissions EMI filter has effectively two differential mode stages. RF1 and C1 form the first differential mode stage. The second differential mode filter stage is formed by L1 and C2.

RF1 should be a 10  $\Omega$  low cost wire-wound fusible resistor or be replaced by a fuse. A resistor is preferable to a fuse as it also limits inrush current and protects against input voltage transients and surges (differential or normal mode). Lower values increase dissipation ( $V^2/R$  power term) during transients and inrush, while higher values increase steady state dissipation ( $I^2R$ ) and lower overall efficiency. Metal film types should not be used since they do not have a high enough transient power capability to survive line transient and inrush current and may fail prematurely in service.

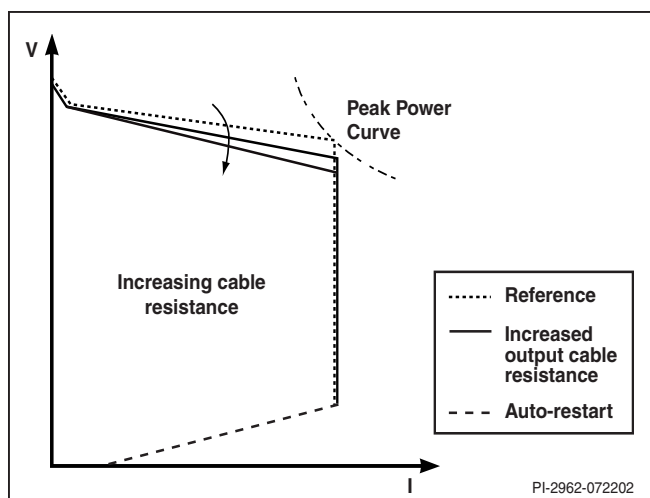

Figure 9. Effect on Output Characteristic Due to Increased Output Cable Resistance.

To meet certain safety agency requirements RF1 should fail open without emitting smoke, fire or incandescent material, that might damage the primary-to-secondary insulation barrier. Consult with a safety engineer or local safety agency for specific guidance.

Diodes D1-D4 should be rated at 400 V or above and be standard recovery types to minimize EMI.

The combined value of C1 and C2 should be selected to give 3  $\mu\text{F}$  per watt (of output power), giving acceptable voltage ripple for universal designs. For high single input voltage ranges (185 VAC to 265 VAC), this recommendation can be reduced to 1  $\mu\text{F}/\text{W}$ , however ripple current ratings and differential mode line transient performance should be verified.

L1, which is effective for low frequencies, is typically in the range of 680  $\mu\text{H}$  to 2.2 mH and should have a current rating of  $\geq 80$  mA RMS.

## Hints and Tips

### Transformer Construction

Since the primary inductance is crucial in setting the peak output power, the tolerance of this parameter should be well controlled. For a CC tolerance at the peak power point of  $\pm 20\%$  /  $\pm 25\%$  (LNK501/LNK500, respectively) the primary inductance tolerance should be  $\pm 10\%$  or better.

Tolerance of ungapped core permeability limits minimum gap size for center leg gapping. For an EE13 core size, the practical minimum center leg gap size, for an overall primary inductance tolerance of  $\pm 10\%$ , is  $\sim 0.08$  mm. This varies with core supplier, so this should be verified before committing to a design.

Other gapping techniques allow tighter tolerances, but may not be universally supported, so again, this should be verified with the preferred magnetics vendor. Film gapping, where thin material spaces all three legs of the core, allows better mechanical tolerance and improves overall primary inductance tolerance to  $\pm 7\%$  with a 0.05 mm gap. Since a gap now appears on the outer legs of the core, flux spraying may result, causing pick up in the input filter components and resulting in poorer than expected conducted EMI. This can be prevented, if necessary, by adding a single shorted turn of copper foil around the outside of the transformer core also known as a “belly band.”

Core gaps should be uniform. Uneven core gapping (see Figure 8), especially with small gap sizes, may cause variation in the primary inductance with flux density (partial saturation) and make the constant current region nonlinear. To verify uniform gapping, it is recommended that the primary switching current waveshape be examined while feeding the supply from a DC source. The slope is defined as  $di/dt = V/L$  and should remain constant throughout the MOSFET on time. Any change in slope of the current ramp is an indication of uneven gapping.

### Verifying Discontinuous Mode Operation

To verify a design will remain discontinuous conduction mode under worst case condition use Equation 27:

$$\frac{2 \times I_{O(MAX)} \times f_{S(MAX)} \times L_{P(MAX)}}{D \times (1 - D) \times V_{DC(MIN)}} < \frac{N_P}{N_S} \quad (27)$$

where  $I_{O(MAX)}$  is the output current (A) at maximum CC tolerance (typically  $I_{O(NOM)} + 20\%$ ),  $f_{S(MAX)}$  is the maximum *LinkSwitch* switching frequency (Hz),  $L_{P(MAX)}$  is the primary inductance (H) at maximum tolerance,  $D$  is duty cycle at minimum input voltage (typically 0.3 at 85 VAC or 0.13 at 195 VAC) and  $V_{DC(MIN)}$  the minimum DC voltage at lowest input line voltage (typically 100 VDC for 85 VAC and 230 VDC for 195 VAC).

### Effect of Output Cable

Factors such as leakage inductance, the value for  $R_{LF}$ ,  $R_{FB}$  and  $C_{CLAMP}$  have been covered. However, there are other parameters that should be considered when designing with *LinkSwitch*.

If the gauge of wire selected for the output cable is reduced, then the voltage drop across the cable resistance will increase. As seen at the load, this appears as poorer CV operation and lower efficiency, but with the CV/CC transition at the same output current (see Figure 9). Ensure that the voltage drop or resistance of the output cable is acceptable.

### Reducing No-load Voltage with a Pre-load

At very light loads ( $< \sim 5$  mA), the output voltage rises due to secondary peak charging. This can be significantly reduced by the addition of a small pre-load resistor. Figure 10 shows the effect of a 1 mA and 2 mA pre-load on a 9 V output design, reducing the no-load voltage by 1.3 V. This level of pre-load has minimal effect on no-load consumption ( $\sim 10$  mW to 20 mW).

### Minimizing No-Load Consumption

The major factors for no-load or standby consumption are  $P_{BIAS}$  and the capacitive switching loss  $P_{C(LOSS)}$  (Equations 9 and 28). If no-load consumption is too high, then the transformer may be redesigned with a lower  $V_{OR}$ .

Total parasitic capacitance of device and transformer, typically 25 pF to 30 pF, causes a switching loss that increases with input voltage and has a significant effect on standby or no-load output power consumption.

$$P_{C(LOSS)} = \frac{C_{TOT} \times V_{MAX}^2 \times f_S}{2} \quad (28)$$

$V_{MAX}$  is typically 340 V for universal or 230 VAC applications and  $f_S$  is 30 kHz at light or no load. Parasitic capacitance loss  $P_{C(LOSS)}$  is typically 40 mW to 100 mW. This loss is not included in the  $L_P$  calculation as this power is not processed through the core.

To minimize transformer capacitance, double coated magnet wire should be used for the primary winding. The technique of vacuum impregnation should not be used since the varnish acts as a dielectric, increasing winding capacitance. Dip varnishing does not cause this problem.

An RC snubber placed across the output diode also increases no-load consumption. If necessary, minimize the value of the

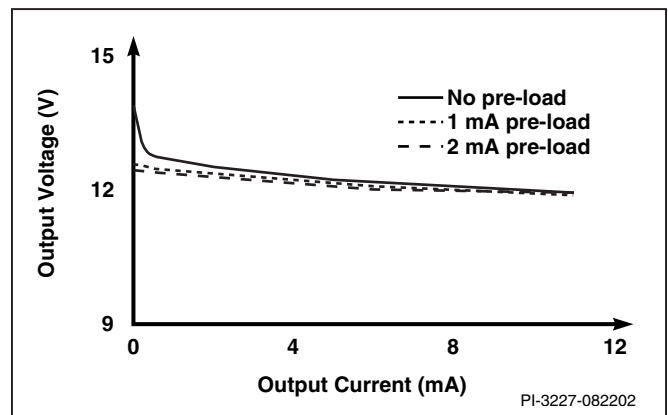

Figure 10. A Small Pre-load can Significantly Reduce No-load Voltage.

capacitor used. If an ultra-fast diode has been selected, try a fast diode as this may allow the snubber to be removed.

### Correct Oscilloscope Connection

To prevent the additional capacitance of an oscilloscope probe from triggering the *LinkSwitch* current limit, do not connect the scope ground to the SOURCE pin. The scope should be connected as shown in Figure 11 to measure source to drain voltage. Since the scope is referenced to the DC rail, an isolation transformer must be used.

### Improving CV Tolerance with Optocoupler

The schematic in Figure 12 shows an example of adding a secondary reference and optocoupler to improve CV tolerance across the entire load range. The voltage drop (sense voltage) across VR1, U1 and R3 sets the nominal output voltage. The

feedback resistor  $R_{FB}$  is split into two to form a divider which limits the voltage across the optocoupler phototransistor. The optocoupler therefore effectively adjusts the resistor divider ratio to control the DC voltage across R2 and the current into the CONTROL pin. For an output tolerance  $\leq \pm 5\%$ , VR1 should be replaced by a reference IC (TL431).

A full description of the operation with an optocoupler can be found in the *LinkSwitch* data sheet.

### Single Point Failure Testing

The *LinkSwitch* circuit requires few considerations for single point failure testing. Breaking the feedback loop by opening either  $R_{LF}$ ,  $D_{CLAMP}$  or  $R_{FB}$  results in *LinkSwitch* entering auto-restart. Under this condition, the secondary output voltage will rise but the output power is limited to  $\sim 8\%$  of normal. This prevents the output capacitor from failing catastrophically. If

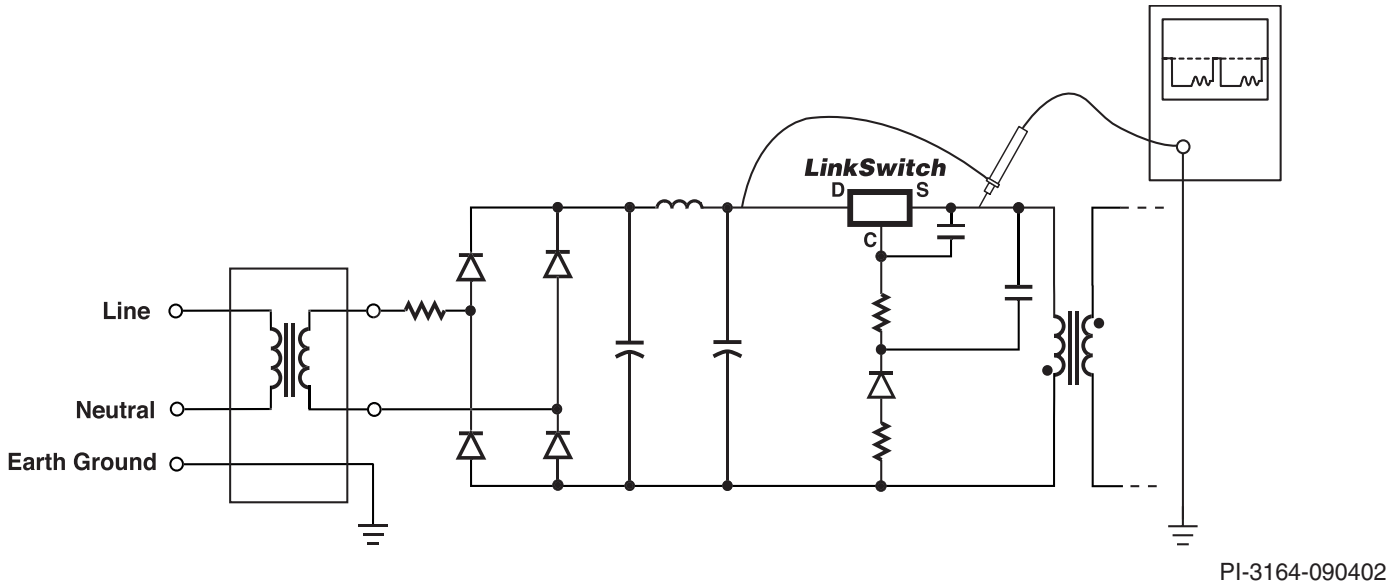

Figure 11. Correct Method of Connecting an Oscilloscope to Measure Switching Waveform.

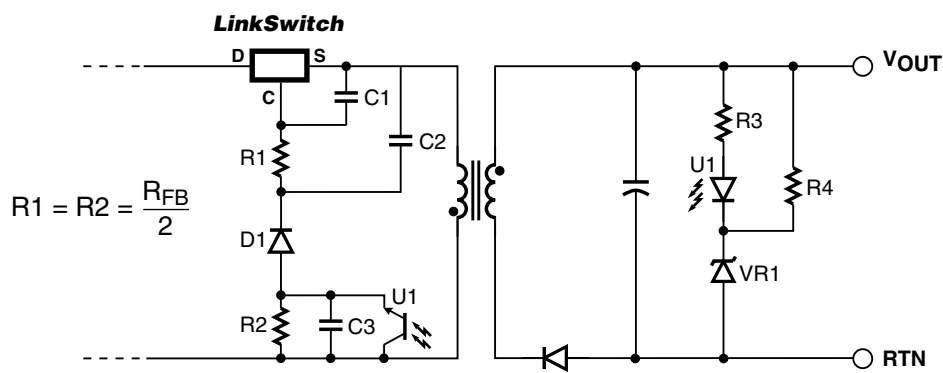

Figure 12. Power Supply Outline Schematic with Optocoupler Feedback.



desired, a 0.5 W Zener can be added across the output to clamp this voltage rise. The Zener voltage should be set above the normal maximum output voltage at no-load. Short circuiting or opening  $C_{CP}$  safely prevents *LinkSwitch* operation.

However, on opening of  $C_{CLAMP}$ , *LinkSwitch* does not enter auto-restart. The output voltage may rise unacceptably high under this condition and cause the failure of the output capacitor. As the supply delivers full power, output clamping requires a Zener power rating equal to or above the nominal output power.

Adding a second capacitor in parallel to  $C_{CLAMP}$  prevents this problem. When  $C_{CLAMP}$  is open circuited the second capacitor acts as  $C_{CLAMP}$ . This second capacitor can be a small value ceramic (0.01  $\mu$ F) capacitor since during normal operation  $C_{CLAMP}$  dominates the parallel combination.

## Appendix A—*LinkSwitch* LNK500/501 Tolerance Analysis

### Output Characteristic Tolerances

Both the device tolerance and external circuit govern the overall tolerance of the *LinkSwitch* power supply output characteristic. For a typical design, the peak power point tolerances are  $\pm 10\%$  for voltage and  $\pm 20\%$  (LNK501) /  $\pm 25\%$  (LNK500) for current limit. This is the estimated overall variation due to *LinkSwitch*, transformer tolerance and line variation in high volume manufacturing.

This appendix provides expressions to allow the calculation of expected circuit variation when in high volume manufacturing for a design employing a LNK501 as shown in Figure 3.

The same analysis can be extended to the LNK500. The only significant difference is a wider  $I^2f$  tolerance ( $\pm 12\%$  compared to  $\pm 6\%$  for LNK501) and associated increase in  $\Delta I/\Delta V$  to  $\pm 3\%$ .

### Constant Current Limit

The peak power point prior to entering constant current operation is defined by the maximum power transferred by the transformer. Since *LinkSwitch* is designed to operate in discontinuous mode, the power transferred is given by the expression  $P = 1/2 L I^2 f$ , where  $L$  is the primary inductance,  $I$  is the primary peak current and  $f$  is the switching frequency.

To simplify analysis, the data sheet parameter table specifies an  $I^2f$  coefficient. This is the product of current limit squared and switching frequency, normalized to the feedback parameter  $I_{DCT}$ . This provides a single term that specifies the variation of the peak power point in the power supply due to *LinkSwitch*.

Additional variations are summarized in Table A1, as both random (unit-to-unit) or statistically independent variations

Variable	Biases	Random	$\Delta I/\Delta V$	Random + $\Delta I/\Delta V$	Biases + Random
Primary Inductance	–	$\pm 10\%$	$\pm 2.5\%$	$\pm 12.5\%$	
$I^2f$	–	$\pm 6\%$	$\pm 1.5\%$	$\pm 7.5\%$	
Input Line	$\pm 3.2\%$	$\pm 3\%$	–	$\pm 3\%$	
CC Linearity	–	$\pm 2\%$	–	$\pm 2\%$	
$T_j$ (25-65°C)	$\pm 1.5\%$	–	–	–	
Totals	$\pm 4.7\%$			$\pm 15\%$	$\pm 19.7\%$

Table A1. Sources of CC Tolerance.

and biases or deterministic variations (apparent in a single unit when tested). This distinction is made since random variations are added using the root-sum-squares method, whereas biases add directly. A further column ( $\Delta I/\Delta V$ ), applicable to the  $I^2f$  and  $L_p$  terms, contains the value including the effect of the change in output current with output voltage. This is necessary because the CV slope is nonzero. Therefore, for example, if the peak power increases, the voltage at the new peak power point tends to be lower, further increasing the output current.

The figure of  $\pm 19.7\%$  in Table A1 is the overall variation of the CC region.

It is important to note that the figure of  $\pm 2\%$  for constant current linearity (the straightness of the constant current characteristic) is only valid for designs close to 3 W output power, with a primary inductance of  $\sim 3$  mH. This is due to the internal compensation for drain current  $di/dt$  variations over line voltage. This compensation was arranged to correctly compensate, over a line voltage range of 85 VAC to 265 VAC, with a primary inductance of 3 mH. In lower power designs, where the primary inductance is lower, an error results which increases the non-linearity in the CC curve.

Output diode of choice also effects CC linearity. The value in Table A1 is based on a Schottky diode. The slower forward recovery time of a PN diode can cause the CC characteristic to bend outwards with falling output voltage.

### Constant Voltage Operation at Peak Power Point

During CV operation, the output characteristic is controlled by adjusting the duty cycle, based on the voltage  $V_{FB}$  across capacitor  $C_{CLAMP}$  (Figure 1). A number of parameters define the actual output voltage, and therefore, the tolerance of the output voltage at the peak power point. The key parameters to consider are:

- Current variation through  $R_{FB}$  due to line voltage variation
- CONTROL pin voltage -  $V_{C(IDCT)}$



- Output diode forward voltage -  $V_{DOUT}$
- Current variation through  $R_{FB}$  due to CONTROL pin voltage tolerance at 30% Duty Cycle ( $I_{DCT}$ )
- Feedback resistor tolerance -  $\Delta\%_{RFB}$

Each of the key parameters above is examined in turn.

The most significant variation in the output voltage is the change with input line.

The voltage across  $R_{FB}$  is defined at  $I_{DCT}$ , corresponding to a 30% duty cycle at low line voltage. At higher line voltage, the CONTROL pin current increases and the voltage across  $R_{FB}$  increases. The change in voltage across  $R_{FB}$ ,  $\Delta V_{RFB(LINE)}$ , depends on the change in duty cycle  $\Delta DC$ , the corresponding change in CONTROL pin current  $\Delta I_C$  (mA) and the value  $R_{FB}$  (k $\Omega$ ). The change in CONTROL pin current for a given change in duty cycle can be found from a curve in the *LinkSwitch* data sheet.

$$\Delta V_{RFB(LINE)} = \Delta I_C \times R_{FB} \quad (A1)$$

For a universal input voltage design,  $\Delta DC$  from low line to high line is typically 0.2 (0.09 for a single input design) giving a change in CONTROL pin current of typically 0.15 mA.

The value of  $\Delta V_{RFB(LINE)}$  should be expressed as a percentage of  $V_{FB}$  to give the variation at the power supply output. The expression for line variation (at the peak power point) is therefore:

$$\Delta\%_{LINE} = \pm \frac{\Delta V_{RFB(LINE)}}{2 \times V_{FB}} \times 100\% \quad (A2)$$

The CONTROL pin voltage  $V_{C(IDCT)}$  is specified at a current equal to  $I_{DCT}$ , giving a duty cycle of 30% for a typical design at the peak power point, at 85 VAC input. The tolerance of this parameter includes temperature variation and can be read from the data sheet directly. Since the output voltage is actually controlled using  $V_{FB}$ , the variation of  $V_{C(IDCT)}$  must be expressed as a percentage of  $V_{FB}$ . The expression for this is given by:

$$\Delta\%_{VC(IDCT)} = \pm \frac{V_{C(IDCT)(MAX)} - V_{C(IDCT)(TYP)}}{V_{FB}} \times 100\% \quad (A3)$$

Any variation in the output diode forward drop with temperature will cause a change in the output voltage. Expressing as a percentage of  $V_O$  gives the expression:

$$\Delta\%_{VDOUT} = \pm \frac{\Delta V_{DOUT}}{2 \times V_O} \times 100\% \quad (A4)$$

Typical values for the change in forward voltage for a temperature change of +50 °C are +0.1 V for a silicon PN diode and +0.025 V for Schottky diode. For device-to-device variations, please consult diode manufacturer.

Any change in the current through  $R_{FB}$ , due to the tolerance of the CONTROL pin current at 30% duty cycle,  $I_{DCT}$ , will also cause a change in the output voltage. The change in the voltage across  $R_{FB}$  (k $\Omega$ ) due to the tolerance of  $I_{DCT}$  (mA) is given by:

$$\Delta V_{RFB(IDCT)} = \pm \frac{I_{DCT(MAX)} - I_{DCT(MIN)}}{2} \times R_{FB} \quad (A5)$$

Expressed as a percentage of the voltage across  $V_{FB}$ , the variation is:

$$\Delta\%_{IDCT} = \pm \frac{\Delta V_{RFB(IDCT)}}{V_{FB}} \times 100\% \quad (A6)$$

The overall variation can then be estimated using the expression:

$$\Delta\%_{CV} = \pm \Delta\%_{LINE} \pm \Delta\%_{VDOUT} \pm \sqrt{\Delta\%_{VC(IDCT)}^2 + \Delta\%_{IDCT}^2 + \Delta\%_{RFB}^2} \quad (A7)$$

Using the design shown in Figure 3 as an example:

$$\Delta\%_{VC(IDCT)} = \pm \frac{6 \text{ V} - 5.75 \text{ V}}{54.2 \text{ V}} \times 100\% = \pm 0.46\% \quad (A8)$$

$$\Delta\%_{VDOUT} = \pm \frac{0.025 \text{ V}}{2 \times 5.5 \text{ V}} \times 100\% = \pm 0.23\% \quad (A9)$$

$$\Delta V_{RFB(LINE)} = 0.15 \text{ mA} \times 20.5 \text{ k}\Omega = 3.1 \text{ V} \quad (A10)$$

$$\Delta\%_{LINE} = \pm \frac{3.1 \text{ V}}{2 \times 54.2 \text{ V}} \times 100\% = \pm 2.9\% \quad (A11)$$

$$\Delta V_{RFB(IDCT)} = \pm \frac{2.36 \text{ mA} - 2.24 \text{ mA}}{2} \times 20.5 \text{ k}\Omega = \pm 1.23 \text{ V} \quad (A12)$$

$$\Delta\%_{IDCT} = \pm \frac{1.23 \text{ V}}{54.2 \text{ V}} \times 100\% = \pm 2.27\% \quad (A13)$$

The tolerance of  $R1$  ( $R_{FB}$ ) is 1%.

$$\begin{aligned} \Delta\%_{CV} &= \pm 2.9\% \pm 0.23\% \pm \sqrt{(0.46^2 + 2.27^2 + 1^2)} \\ &= \pm 2.9\% \pm 0.23\% \pm 2.52\% \\ &= \pm 5.65\% \end{aligned} \quad (A14)$$



The overall tolerance is the sum of the deterministic variation due to the change in line voltage and the change in the output diode forward voltage with temperature, together with the root-sum-square addition of the statistically independent circuit and device variables.

In Equation A14 the  $\Delta\%_{\text{LINE}}$  term ( $\pm 2.9\%$ ) is the expected change in output voltage for a change of  $\pm 90$  VAC at 175 VAC, the mid point of the specified input voltage range of 85 VAC to 265 VAC.

Equivalently, starting with the reference as 85 VAC, the output voltage would increase  $+5.8\%$  (twice  $2.9\%$ ) when the input increases to 265 VAC.

The analysis above is for a specific example, factors such as diode choice, temperature range and output voltage can result in a larger tolerance. However, for most cases the designer can be confident the overall tolerance will be  $< \pm 10\%$ .

Note that all of the above tolerances other than  $R_{\text{FB}}$  and  $V_{\text{C(IDCT)}}$  are compensated or accounted for in the previous analysis of CC tolerance. The contributions of  $R_{\text{FB}}$  and  $V_{\text{C(IDCT)}}$ , since they are unit-to-unit tolerances, have a very small influence ( $< 0.1\%$  on the total sum of unit-to-unit tolerances).

### Constant Voltage Operation Below Peak Power Point

As the output load reduces from the peak power point, the output voltage will tend to rise due to tracking errors compared to the load terminals. Sources of these include the output cable drop, output diode forward voltage and leakage inductance, which is the dominant cause.

As the load reduces, the primary operating peak current reduces, together with the leakage inductance energy, which reduces the peak charging of  $C_{\text{CLAMP}}$ . With a primary leakage inductance figure of  $50 \mu\text{H}$ , the output voltage typically rises  $40\%$  from full to no-load.

## Appendix B: Considerations When Designing With Low-Side *LinkSwitch* LNK520 Devices

### Introduction

The LNK500/501 and LNK520 differ in the circuit location of the *LinkSwitch* device. The LNK500/501 is designed for high-side operation and the LNK520 is designed for low-side operation with a bias winding. The low-side configuration reduces common mode EMI as the source is connected to the quiet primary return. This reduces the variation in EMI performance as the PCB layout is altered and allows the source heatsinking PCB area to be maximized without EMI penalty. In addition, the

switching characteristic of the LNK520 has been optimized, reducing radiated EMI by up to 5 dB. A summary of the comparisons between the two families is shown in Table B2.

### LNK520 QUICK START

Figure B1 shows the key parameters and components needed to generate an initial *LinkSwitch* LNK520 design. Where initial estimates can be used, they are shown below the parameter they refer to.

- 1) Let  $V_{\text{OR}}$  equal 50 V.  
Standby losses increase with increasing  $V_{\text{OR}}$  due to primary parasitic capacitance (see Equation 28)
- 2) Let  $V_{\text{BIAS}}$  equal 15 V to 25 V.  
CC regulation improves but standby losses increase with increasing bias voltage.
- 3) Define the transformer turns ratio according to Equation 5. If no better estimates or measurements are available, then let  $V_{\text{DOUT}}$  equal 0.7 V for a Schottky or 1.1 V for a PN diode,  $R_{\text{CABLE}}$  equal  $0.3 \Omega$ ,  $R_{\text{SEC}}$  equal  $0.15 \Omega$ ,  $I_{\text{SEC(RMS)}}$  equal  $2 \times I_{\text{O}}$ , and  $I_{\text{SEC(PEAK)}}$  equal  $4 \times I_{\text{O}}$ , where  $I_{\text{O}}$  is the desired CC output current and  $V_{\text{O}}$  is the desired output voltage at the CV/CC transition point.
- 4) Calculate  $P_{\text{O(EFF)}}$  according to Equation 13. As an initial estimate for  $P_{\text{CORE}}$  use 0.1 W.
- 5) Calculate  $L_{\text{P}}$  according to Equation 14 and other transformer parameters from Equations 15, 16, 17, 18 and 19. Increase value from Equation 14 by 4%.
- 6) Calculate value for feedback resistor  $R_{\text{FB}}$  according to Equations B3, B4, B5, B6, and B7. This should be 1/4 W, 1% part.
- 7) Set bias capacitor  $C_{\text{BIAS}}$  as  $1.0 \mu\text{F}$ , 50 V aluminum electrolytic type.
- 8) Set  $R_{\text{CLAMP2}}$  as  $100 \Omega$ , 1/4 W, select the largest  $R_{\text{CLAMP1}}$  and smallest  $C_{\text{CLAMP}}$  to keep  $V_{\text{DS}} < BV_{\text{DSS}}$  at maximum line voltage, peak output power.
- 9) Set  $R_{\text{LF}}$  as  $200 \Omega$  for high leakage inductance or  $15 \Omega$  for low transformer leakage values.
- 10) Set CONTROL pin capacitor  $C_{\text{CP}}$  to be  $0.22 \mu\text{F}$ , 10 V for battery loads or  $1 \mu\text{F}$ , 10 V for resistive loads.
- 11) Select input and output components. See Figure B1 and relevant sections.
- 12) Construct prototype.
- 13) Iterate design (see Hints and Tips section).

Table B1. LNK520 Quick Start.





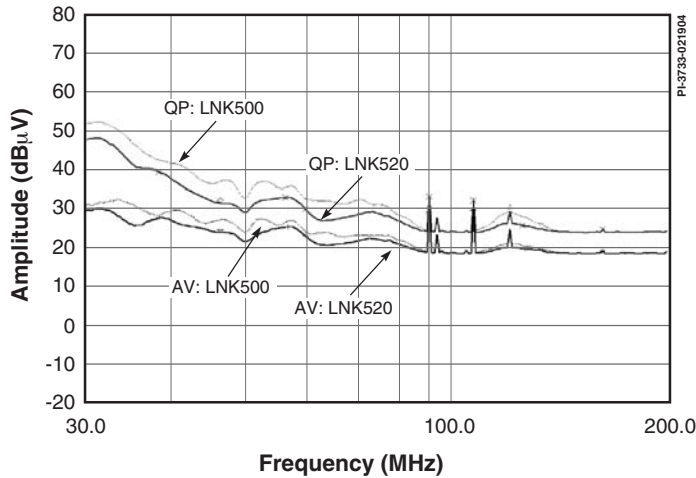

Figure B2. Comparison of LNK520 and LNK500 Showing an Approximate 5 dBµV Reduction in Radiated EMI.

**Scope**

This appendix is for engineers designing an AC-DC flyback power supply using the LNK520 device, expanding on the information already presented. Unless noted, designing with the LNK520 is consistent with the LNK500.

For readers who want to generate a design as quickly as possible, the Quick Start section provides enough information to generate an initial prototype.

**CV/CC Circuit Design**

The LNK520 circuit shown in Figure B3 serves as a CV/CC charger example to illustrate design techniques. The low-side

configuration requires the addition of a primary side bias winding and filtering components to allow the output voltage to be sensed. Bias turns ( $N_B$ ) are selected to maintain approximately 20 V at the nominal constant voltage (CV) peak power point.

Adjustment of the bias voltage and filtering components is required to compensate for leakage inductance imbalance between secondary and bias windings, which varies according to transformer construction. See the following sections for details on selection of clamp and feedback components required in the Low-side configuration. An output pre-load of a few milliamps may be necessary to reduce the no-load output voltage.

**Transformer Design**

Follow LNK520 guidelines with the following exceptions:

- 1)  $V_{OR}$  range is 40 V to 80 V.
- 2) To correctly center the output peak power point over temperature increase the calculated  $L_p$  value by +4% at 85 VAC, -3% at 195 VAC.
- 3) Primary inductance tolerance ( $L_p$ ) should be within  $\pm 7.5\%$  (to meet CC tolerance of  $\pm 20\%$  for LNK521,  $\pm 24\%$  for LNK520).
- 4) Use an initial value for secondary turns of 1 to 3 turns per volt across the secondary winding. Calculate the number of bias turns, rounding to the nearest integer, according to equation B1, using an initial estimate for the bias voltage of 20 V and  $V_{SEC(EST)} = V_o + V_{DOUT}$ .

$$N_B = \frac{V_{BIAS}}{V_{SEC}} \times N_S \tag{B1}$$

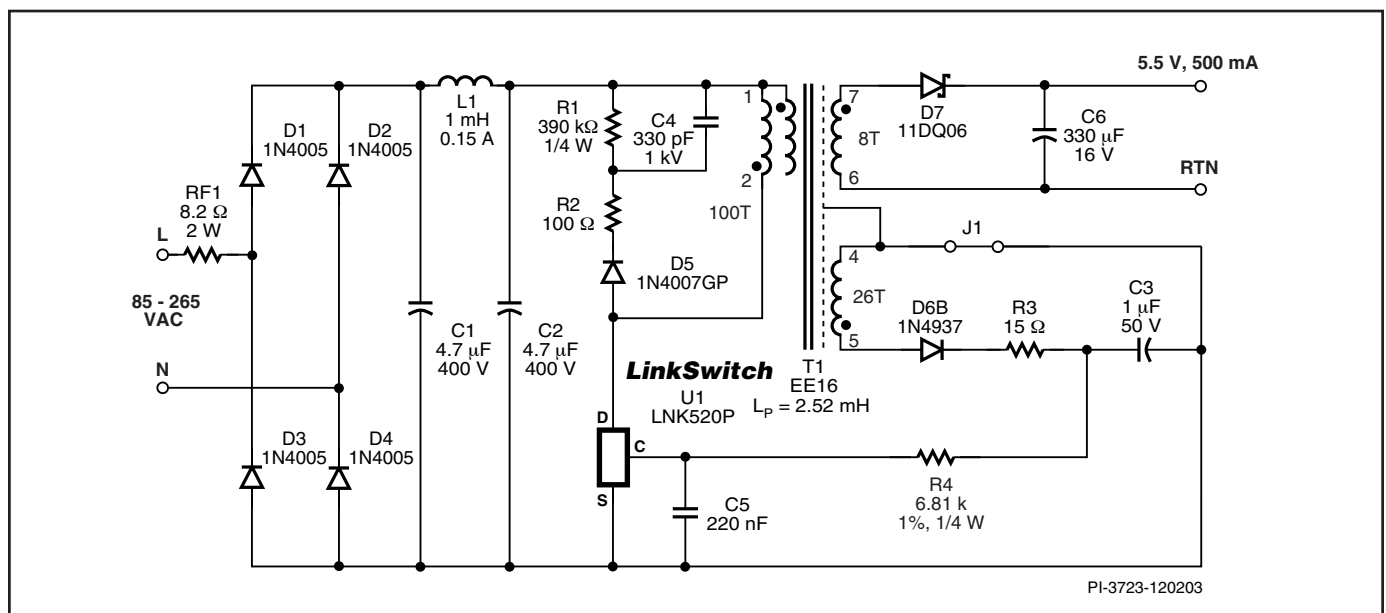

Figure B3. Example LNK520 Schematic for a Typical LinkSwitch Charger.



Using the design in figure B3 as an example:

$$\begin{aligned}
 N_B &= \frac{V_{BIAS}}{V_{SEC(EST)}} \times N_S \\
 &= \frac{20 \text{ V}}{(5.5 \text{ V} + 0.7 \text{ V})} \times 8 \\
 &= 25.8 \\
 &= 26 \text{ turns}
 \end{aligned} \tag{B2}$$

### Clamp, Bias, Bypass and Feedback

An RCD clamp network is formed by  $R_{CLAMP1}$ ,  $C_{CLAMP}$ ,  $D_{CLAMP}$  and  $R_{CLAMP2}$  (Figure B1), safely limits the maximum drain voltage to below the  $BV_{DSS}$  of *LinkSwitch*.

Feedback is derived from the bias winding voltage ( $V_{BIAS}$ ), that closely approximates the secondary winding voltage ( $V_{SEC}$ ) multiplied by the bias winding to secondary winding turns ratio ( $N_B:N_S$ ). Due to the effects of leakage inductance ( $V_{LEAK}$ ) the actual  $V_{SEC}$  may be slightly different than calculated, causing an error in the output voltage. To minimize this effect a bias voltage higher than the output voltage is used (limited by no-load consumption) and  $R_{LF}$  together with  $C_{BIAS}$  filter leakage inductance generated voltage spikes.

The bias voltage is converted by  $R_{FB}$  to *LinkSwitch* CONTROL pin current for duty cycle control and bias. The CONTROL pin capacitor  $C_{CP}$  provides decoupling, control loop compensation, and the energy storage required during start-up and auto restart.

The location of  $D_{BIAS}$  may be on the positive or return side of the bias winding depending on if and how the bias winding is configured as primary side core cancellation winding. Similar considerations apply to  $D_{OUT}$  if a shield winding is used between primary and secondary windings.

### Feedback Resistor ( $R_{FB}$ )

To calculate the feedback resistor value the value of the feedback voltage must be determined. Using the schematic shown in Figure B3 as an example. With primary turns  $N_p = 100$  and secondary turns  $N_s = 8$  the peak secondary current can be calculated from equation B3, where  $I_{PRI(PEAK)}$  is equal to the *LinkSwitch* typical current limit  $I_{LIM(TYP)}$ .

$$\begin{aligned}
 I_{SEC(PEAK)} &= \frac{N_p}{N_s} \times I_{PRI(PEAK)} \\
 &= \frac{100}{8} \times 0.254 \\
 &= 3.175 \text{ A}
 \end{aligned} \tag{B3}$$

The secondary diode peak voltage was measured as 0.7 V, the secondary winding resistance as 0.1  $\Omega$  and the cable resistance as 0.2  $\Omega$ . Therefore  $V_{SEC}$  is defined as:

$$\begin{aligned}
 V_{SEC} &= V_O + V_{RCABLE} + V_{DOUT} + V_{RSEC} \\
 &= V_O + (I_O \times R_{CABLE}) + V_{DOUT} + (I_{SEC(PEAK)} \times R_{SEC}) \\
 &= 5.5 \text{ V} + (0.5 \text{ A} \times 0.2 \Omega) + 0.7 \text{ V} + (3.175 \text{ A} \times 0.1 \Omega) \\
 &= 5.5 \text{ V} + 0.1 \text{ V} + 0.7 \text{ V} + 0.3175 \text{ V} \\
 &= 6.62 \text{ V}
 \end{aligned} \tag{B4}$$

Voltage  $V_{SEC}$  allows the exact  $V_{BIAS}$  to be calculated:

$$\begin{aligned}
 V_{BIAS} &= \frac{N_B}{N_S} \times V_{SEC} \\
 &= \frac{26}{8} \times 6.62 \\
 &= 21.5 \text{ V}
 \end{aligned} \tag{B5}$$

Resistor  $R_{FB}$ , a 1% 0.25 W resistor converts the bias voltage to *LinkSwitch* bias and control current.

Feedback voltage  $V_{FB}$  is calculated from  $V_{BIAS}$ , the error due to leakage inductance  $V_{LEAK}$  and the voltage drop across  $D_{BIAS}$ .

The value for  $V_{LEAK}$  varies depending on the value of the leakage inductance, the size of the filter resistor  $R_{LF}$  and the forward drop of  $D_{BIAS}$ . For the first prototype use a value of between 0 V and 2 V for  $V_{LEAK}$  and 1 V for  $V_{DBIAS}$ .

$$V_{FB} = V_{BIAS} + V_{LEAK} - V_{DBIAS} \tag{B6}$$

Once a prototype has been constructed, the value of  $V_{FB}$  can be found directly, by measuring the voltage across  $C_{BIAS}$  at the power supply peak power point using a DVM. By subtracting  $V_{BIAS}$  and  $V_{DBIAS}$  from  $V_{FB}$  the value for  $V_{LEAK}$  can be determined, useful as an estimate in future designs. For the design shown in Figure B3,  $V_{FB}$  was measured as 20.7 V, giving  $V_{LEAK}$  as 0.2 V.

An initial value for  $R_{FB}$  is calculated from  $V_{FB}$ , the CONTROL pin voltage  $V_{C(IDCT)}$  and current  $I_{DCT}$ , as specified in the *LinkSwitch* data sheet.

$$\begin{aligned}
 R_{FB} &= \frac{V_{FB} - V_{C(IDCT)}}{I_{DCT}} \\
 &= \frac{20.7 \text{ V} - 5.75 \text{ V}}{2.15 \text{ mA}} \\
 &= 6.9 \text{ k}\Omega
 \end{aligned} \tag{B7}$$

Select the nearest standard value and adjust to center the output voltage. The example in Figure B3 uses a value of 6.81 k $\Omega$  for  $R_{FB}$ , centering the output voltage at the peak power point.

Note that  $R_{FB}$  power dissipation should be taken into account when calculating the no load power consumption.

$$P_{RFB} = (2.15 \text{ mA})^2 \times R_{FB} = 31 \text{ mW} \tag{B8}$$



## Bias Filter Resistor ( $R_{LF}$ ) and Capacitor ( $C_{BIAS}$ )

Follow guidance for LNK520 with the following exceptions:

- 1) The value for bias series resistor  $R_{LF}$  is sized between  $0\ \Omega$  and  $300\ \Omega$ , depending on leakage characteristics of the transformer. Larger resistor sizes are necessary to filter leakage spike on the bias winding but will reduce the slope in the CV region. Increased  $R_{LF}$  will result in a slight reduction in auto-restart and “discharged battery” minimum start-up voltage.
- 2)  $C_{BIAS}$  capacitor is a  $1\ \mu\text{F}$ ,  $50\ \text{V}$  Aluminum electrolytic type. The voltage rating is consistent with the  $20\text{-}30\ \text{V}$  maximum seen across the bias winding. This forms an effective filter with  $R_{LF}$  for bias leakage voltage spikes and improves CV/CC performance.
- 3)  $D_{BIAS}$  can be a signal diode such as the 1N4148 or BAV20 with suitable voltage rating. For lower radiated EMI a slower diode such as the 1N4937 may be considered, which also improves regulation.

## Primary Clamp Resistors ( $R_{CLAMP1}$ , $R_{CLAMP2}$ ), Diode ( $D_{CLAMP}$ ) and Capacitor ( $C_{CLAMP}$ ) \*

Diode  $D_{CLAMP}$  can be a normal, fast or ultra-fast recover type with at least a  $600\ \text{V}$  breakdown voltage. Slow recovery diodes (1N400X) are preferred as they offer better light and no load CV regulation and reduce EMI. However they should be glass passivated and used with a series resistor ( $R_{CLAMP2}$ ) to damp ringing and prevent reverse pull out current, this also further reduces EMI.

The clamp resistor  $R_{CLAMP1}$  is required to dissipate stored leakage energy between subsequent switching cycles.

$C_{CLAMP}$  limits the peak drain voltage and should be sized between  $100$  and  $2000\ \text{pF}$ ,  $500\ \text{V}$ .  $C_{CLAMP}$  capacitor can be low cost disc ceramic-type. As a general rule the value of the  $C_{CLAMP}$  should be minimized and the value of  $R_{CLAMP1}$  maximized while still keeping the peak drain voltage (at highest line voltage) below  $BV_{DSS}$ .

## Secondary Snubber Resistor ( $R_{SNUB}$ ) and Capacitor ( $C_{SNUB}$ ) \*

A secondary diode snubber may be required to attenuate conducted EMI, especially in the high frequency band.  $C_{SNUB}$  should be in the range  $10$  and  $100\ \text{pF}$  and  $R_{SNUB}$  between  $10$  and  $100\ \Omega$ ,  $1/8\ \Omega$ .

\*Sizing of primary clamp and secondary snubber components may require iterative analysis to minimize no-load consumption and no-load output voltage.

## Hints and Tips

### Improving CV Tolerance with Optocoupler

A secondary reference and optocoupler may be added to reduce the CV tolerance, maintained over the full output load range. Figure B4 shows an example using a Zener (VR1) as the secondary reference. During CV operation,  $R_{FB}$  is bypassed by U1 and the output voltage is defined by the voltage across VR1,  $R_A$  and the LED of U1.

Resistor  $R_B$  is selected to bias VR1 close to its specified test current. It may also be used to center the output voltage. Resistor  $R_A$  is optional and limits the current through U1 when there is a large output ripple.

Beyond the peak power point, the output voltage falls and no current flows through VR1 or U1. The power supply is therefore in CC operation and CONTROL pin current is provided through feedback resistor  $R_{FB}$ .

The initial value of  $R_{FB}$  is calculated using Equation B9, the same calculation whether or not an optocoupler is used.

## Appendix C: Low Side *LinkSwitch* LNK520 Tolerance Analysis

### Output Characteristic Tolerances

The tolerance analysis for the LNK520 follows the same approach as used for the LNK500/501, as described in Appendix A. As such only a summary of the analysis is presented here, highlighting differences between the LNK520 and LNK500/501 devices. Table C1 and C2 provide the overall constant current tolerance values and Equation C8 provides the voltage tolerance of the peak power point, for the design in Figure B3.

### Constant Current Limit (CC)

Key differences from LNK500/501 analysis.

- Primary inductance tolerance
  - Based on feedback from customers and transformer vendors the primary inductance has been reduced.
- $\Delta I\Delta V$  terms
  - Improved regulation when using a bias winding has reduced  $\Delta I\Delta V$  terms.
- Biases due to temperature, CC linearity and temperature
  - Device biases have been lumped into a single term of  $\pm 7.9\%$ . Note: variation due to temperature has a larger negative coefficient than positive but has been centered here for simplicity. In practice when optimizing the design at room ambient and  $85\ \text{VAC}$  the peak power point should be adjusted to  $4\%$  higher than the desired nominal CC output current.

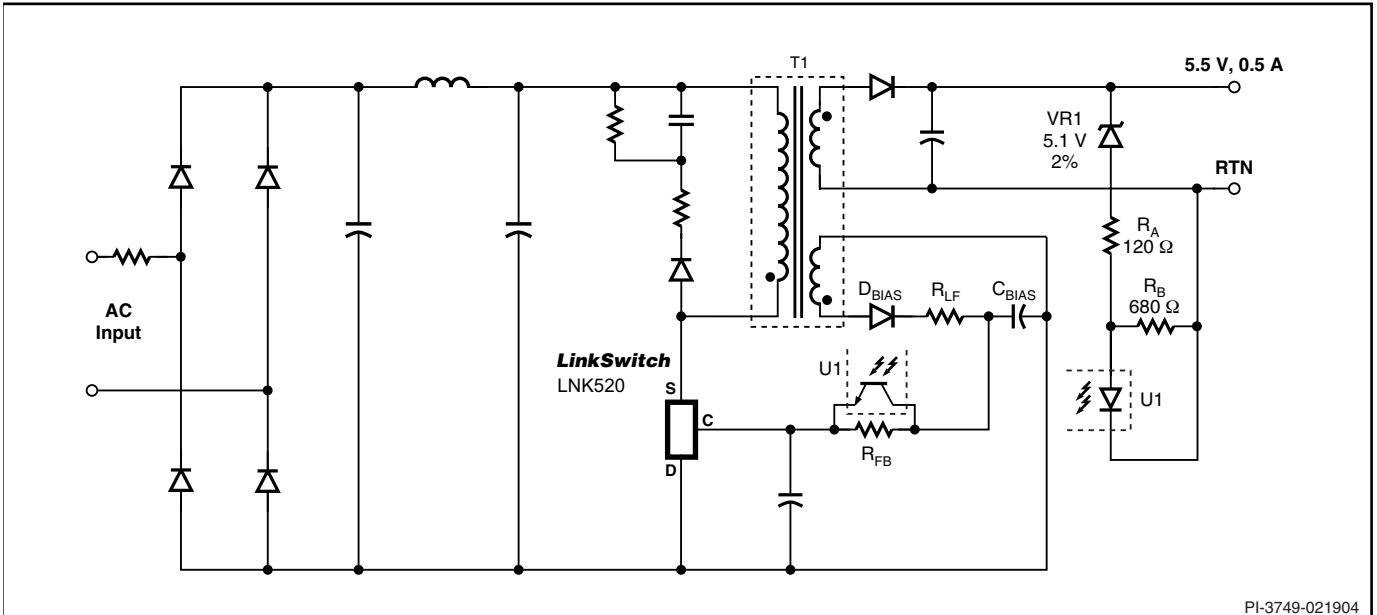

Figure B4. Example of LNK520 with Optocoupler Feedback.

Variable	Biases	Random	$\Delta I/\Delta V$	Random + $\Delta I/\Delta V$	Biases + Random
Primary Inductance	-	$\pm 7\%$	$\pm 1.1\%$	$\pm 8.1\%$	
$I^2t$	-	$\pm 11\%$	$\pm 1.7\%$	$\pm 12.7\%$	
Input Line		$\pm 3\%$	-	$\pm 3\%$	
CC Linearity	$\pm 7.9\%$	$\pm 2\%$	-	$\pm 2\%$	
$T_j$ (25-65°C)		-	-	-	
Totals	$\pm 7.9\%$			$\pm 15.5\%$	$\pm 23.4\%$

Table C1. Sources of LNK520 CC Tolerance.

$$\Delta V_{RFB(LINE)} = 0.15 \text{ mA} \times 6.81 \text{ k}\Omega = 1.02 \text{ V} \quad C3$$

$$\Delta\%_{VDOUT} = \pm \frac{0.025}{2 \times 5.5} \times 100\% = \pm 0.23\% \quad C4$$

$$\Delta\%_{LINE} = \pm \frac{1.02 \text{ V}}{2 \times 20 \text{ V}} \times 100\% = \pm 2.55\% \quad C5$$

$$\Delta V_{RFB(IDCT)} = \pm \frac{2.15 \text{ mA} - 2.06 \text{ mA}}{2} \times 6.81 \text{ k}\Omega = \pm 0.31 \text{ V} \quad C6$$

$$\Delta\%_{IDCT} = \pm \frac{0.31 \text{ V}}{20 \text{ V}} \times 100\% = \pm 1.53\% \quad C7$$

The tolerance of R4 ( $R_{FB}$ ) is 1%

$$\begin{aligned} \Delta\%_{CV} &= \pm 2.55\% \pm 0.23\% \pm \sqrt{(1.46^2 + 1.53^2 + 1^2)} \\ &= \pm 2.55\% \pm 0.23\% \pm 2.34\% \\ &= \pm 5.12\% \end{aligned} \quad C8$$

### Constant Voltage Operation at Peak Power Point

During CV operation, the output characteristic is controlled by adjusting the duty cycle, based on the voltage  $V_{FB}$  across capacitor  $C_{BIAS}$  (Figure B1). The key parameters defining the output voltage are the same for LNK500/501 and LNK520 and therefore the analysis provided earlier (equations A1 through A7) is valid. Using the design in Figure B3 as an example and values from the LNK520 data sheet parametric table:

$$\Delta\%_{CV} = \pm \Delta\%_{LINE} \pm \Delta\%_{VDOUT} \pm \sqrt{\Delta\%_{VC(IDCT)}^2 + \Delta\%_{IDCT}^2 + \Delta\%_{RFB}^2} \quad C1$$

$$\Delta\%_{VC(IDCT)} = \pm \frac{6 \text{ V} - 5.75 \text{ V}}{20 \text{ V}} \times 100\% = \pm 1.25\% \quad C2$$



Revision	Notes	Date
A	–	8/02
B	Added support for LNK500.	4/03
C	Added support for LNK520.	3/04
D	Corrected Table 2 to indicate Figure 2B	8/06

For the latest updates, visit our Web site: [www.powerint.com](http://www.powerint.com)

Power Integrations may make changes to its products at any time. Power Integrations has no liability arising from your use of any information, device or circuit described herein nor does it convey any license under its patent rights or the rights of others. POWER INTEGRATIONS MAKES NO WARRANTIES HEREIN AND SPECIFICALLY DISCLAIMS ALL WARRANTIES INCLUDING, WITHOUT LIMITATION, THE IMPLIED WARRANTIES OF MERCHANTABILITY, FITNESS FOR A PARTICULAR PURPOSE, AND NON-INFRINGEMENT OF THIRD PARTY RIGHTS.

#### PATENT INFORMATION

The products and applications illustrated herein (including circuits external to the products and transformer construction) may be covered by one or more U.S. and foreign patents or potentially by pending U.S. and foreign patent applications assigned to Power Integrations. A complete list of Power Integrations' patents may be found at [www.powerint.com](http://www.powerint.com).

#### LIFE SUPPORT POLICY

POWER INTEGRATIONS' PRODUCTS ARE NOT AUTHORIZED FOR USE AS CRITICAL COMPONENTS IN LIFE SUPPORT DEVICES OR SYSTEMS WITHOUT THE EXPRESS WRITTEN APPROVAL OF THE PRESIDENT OF POWER INTEGRATIONS. As used herein:

1. Life support devices or systems which, (a) are intended for surgical implant into the body, or (b) support or sustain life, and whose failure to perform, when properly used in accordance with instructions for use provided in the labeling, can be reasonably expected to result in a significant injury to the user.
2. A critical component is any component of a life support device or system whose failure to perform can be reasonably expected to cause the failure of the life support device or system, or to affect its safety or effectiveness.

The PI logo, **TOPSwitch**, **TinySwitch**, **LinkSwitch**, **DPA-Switch**, **PeakSwitch**, **Clampless**, **EcoSmart**, **E-Shield**, **Filterfuse**, **StackFET**, **PI Expert** and **PI FACTS** are trademarks of Power Integrations, Inc. Other trademarks are property of their respective companies. ©Copyright 2004, Power Integrations, Inc.

## Power Integrations Worldwide Sales Support Locations

#### WORLD HEADQUARTERS

5245 Hellyer Avenue  
San Jose, CA 95138, USA.  
Main: +1-408-414-9200  
Customer Service:  
Phone: +1-408-414-9665  
Fax: +1-408-414-9765  
*e-mail: [usasales@powerint.com](mailto:usasales@powerint.com)*

#### CHINA (SHANGHAI)

Rm 807-808A  
Pacheer Commercial Centre  
555 Nanjing Rd. West  
Shanghai, P.R.C. 200041  
Phone: +86-21-6215-5548  
Fax: +86-21-6215-2468  
*e-mail: [chinasales@powerint.com](mailto:chinasales@powerint.com)*

#### CHINA (SHENZHEN)

Rm 2206-2207, Block A,  
Electronics Science & Technology Bldg.  
2070 Shennan Zhong Rd.  
Shenzhen Guangdong,  
China, 518031  
Phone: +86-755-8379-3243  
Fax: +86-755-8379-5828  
*e-mail: [chinasales@powerint.com](mailto:chinasales@powerint.com)*

#### GERMANY

Rueckertstrasse 3  
D-80336, Munich, Germany  
Phone: +49-89-5527-3910  
Fax: +49-89-5527-3920  
*e-mail: [eurossales@powerint.com](mailto:eurossales@powerint.com)*

#### INDIA

#1, 14th Main Road  
Vasanthanagar  
Bangalore-560052 India  
Phone: +91-80-41138020  
Fax: +91-80-41138023  
*e-mail: [indiasales@powerint.com](mailto:indiasales@powerint.com)*

#### ITALY

Via De Amicis 2  
20091 Bresso MI – Italy  
Phone: +39-028-928-6000  
Fax: +39-028-928-6009  
*e-mail: [eurossales@powerint.com](mailto:eurossales@powerint.com)*

#### JAPAN

Keihin Tatemono 1st Bldg 2-12-20  
Shin-Yokohama, Kohoku-ku,  
Yokohama-shi, Kanagawa ken,  
Japan 222-0033  
Phone: +81-45-471-1021  
Fax: +81-45-471-3717  
*e-mail: [japansales@powerint.com](mailto:japansales@powerint.com)*

#### KOREA

Rm 602, 6FL  
Korea City Air Terminal B/D, 159-6  
Samsung-Dong, Kangnam-Gu,  
Seoul, 135-728, Korea  
Phone: +82-2-2016-6610  
Fax: +82-2-2016-6630  
*e-mail: [koreasales@powerint.com](mailto:koreasales@powerint.com)*

#### SINGAPORE

51 Newton Road  
#15-08/10 Goldhill Plaza  
Singapore, 308900  
Phone: +65-6358-2160  
Fax: +65-6358-2015  
*e-mail: [singaporesales@powerint.com](mailto:singaporesales@powerint.com)*

#### TAIWAN

5F, No. 318, Nei Hu Rd., Sec. 1  
Nei Hu Dist.  
Taipei, Taiwan 114, R.O.C.  
Phone: +886-2-2659-4570  
Fax: +886-2-2659-4550  
*e-mail: [taiwansales@powerint.com](mailto:taiwansales@powerint.com)*

#### UNITED KINGDOM

1st Floor, St. James's House  
East Street, Farnham  
Surrey GU9 7TJ  
United Kingdom  
Phone: +44 (0) 1252-730-140  
Fax: +44 (0) 1252-727-689  
*e-mail: [eurossales@powerint.com](mailto:eurossales@powerint.com)*

#### APPLICATIONS HOTLINE

World Wide +1-408-414-9660

#### APPLICATIONS FAX

World Wide +1-408-414-9760

