

TOPSwitch-GX[®] Forward Design Methodology

Application Note AN-30



Introduction

The single-ended forward converter topology is often the best solution for AC-DC applications that require higher powers and higher output currents than are practical from flyback converters. The forward converter extends the power capability of TOPSwitch-GX to greater than 200 W for high current outputs.

The feature set of TOPSwitch-GX offers the following advantages in single-ended forward designs:

- Built-in soft-start
- Built-in under-voltage lockout
- Built-in adjustable current limit
- Programmable duty cycle reduction to limit duty cycle excursion at high line and transient load conditions
- Higher efficiency (typically >70%)
- Very good light-load efficiency
- Voltage mode control for simpler loop designs with magnetic amplifier post-regulators
- Built-in remote on-off
- Low component count
- Improved EMI

Scope

This application note is for engineers designing an AC-DC power supply using TOPSwitch-GX TOP248-TOP250 devices in a single-ended forward converter. It addresses single input voltage 230 VAC or doubled 115 VAC input, but does not address universal input (85 V to 265 V) designs. The document highlights design parameters that are fundamental to the use of TOPSwitch-GX in a single-ended forward converter. It offers a procedure to compute transformer turns, output inductance and other design parameters. This procedure enables designers to build an operational prototype in the shortest possible time. Refinement of the prototype hardware after bench evaluation will lead to a final design.

The design methodology presented here is sufficiently general to cover a variety of single-ended forward designs, including power supplies for personal computers. It provides for multiple outputs with coupled inductors, independent multiple outputs, and outputs with both linear or magnetic amplifier post regulators.

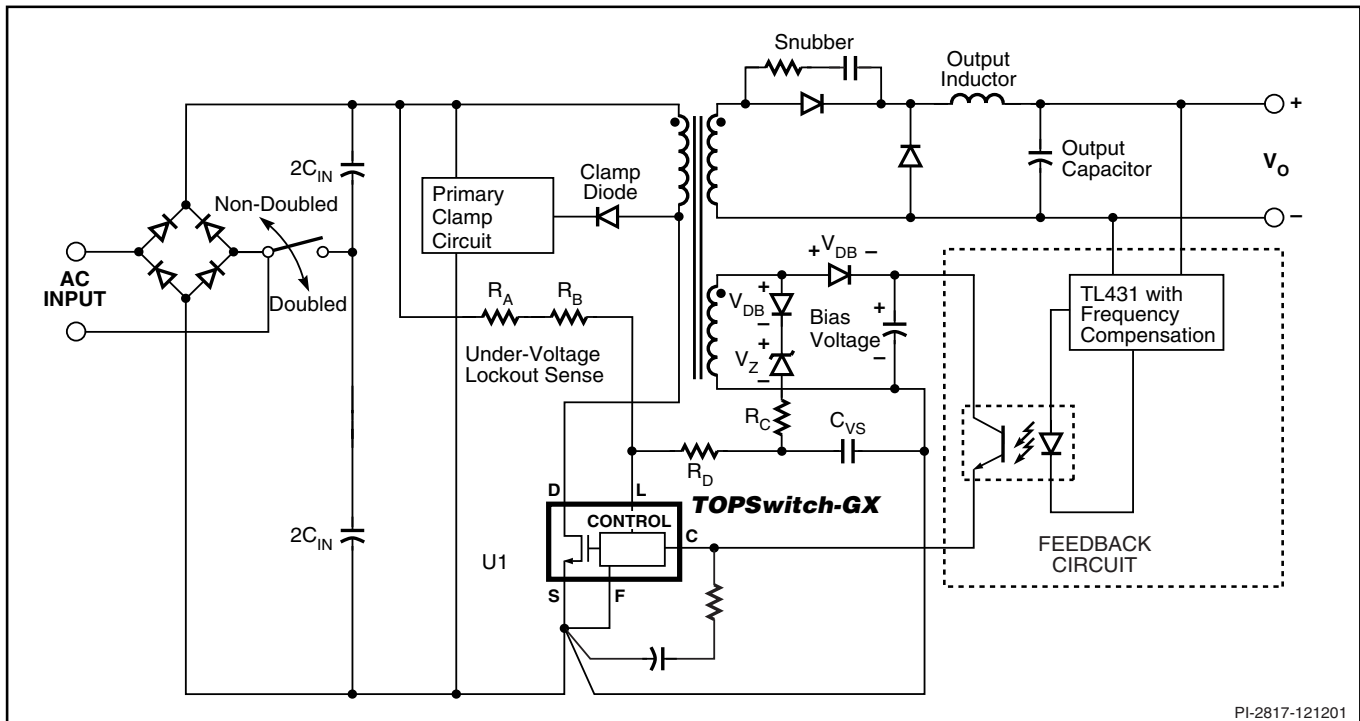

PI-2817-121201

Figure 1. Typical Configuration of TOPSwitch-GX in a Single-Ended Forward Converter.

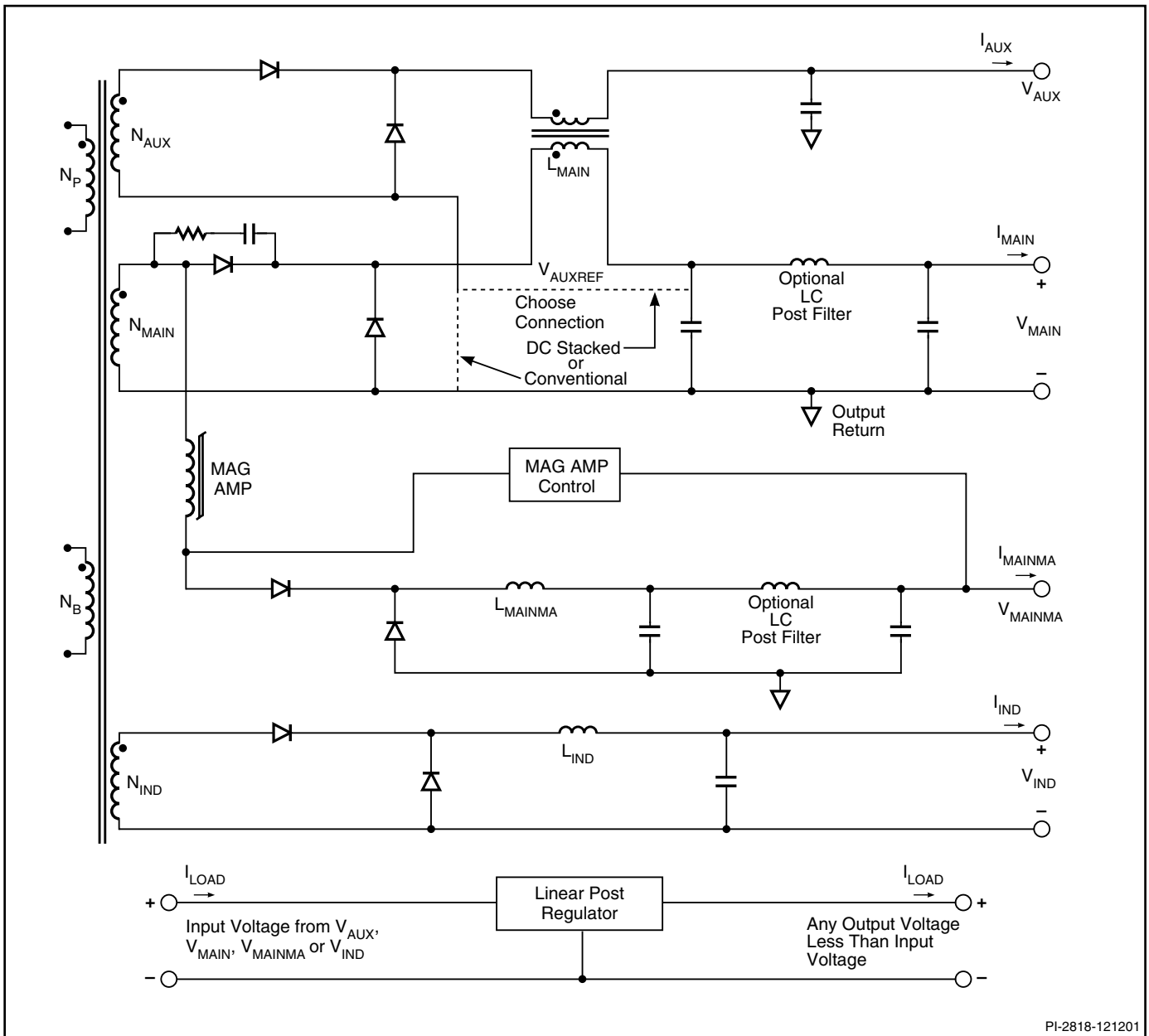

PI-2818-121201

Figure 2. General Output Options for the Forward Converter Described in the Methodology.

This document does not address the design of magnetic amplifiers nor linear regulators. It determines design parameters for the transformer and the inductors, but does not give construction details for those magnetic components. Such details are deferred to other application notes and component suppliers. References [1] through [6] are good sources of information for the design of transformers and inductors. Software for design of magnetic amplifiers is available from [5]. Reference [1] is also an excellent resource for other important topics in power electronics.

Design Methodology Overview

The methodology assumes the reader knows the theory of operation of the forward converter and the fundamentals of power supply design. It is a companion to the *PI Expert* software for forward converter design (available from the Power Integrations Web site). Designers are advised to check Power Integrations' Web site at www.powerint.com for the latest application information.

This presentation uses a typical combination of output options for illustration of the methodology (see Figure 2). This document

gives the basic expressions illustrating the methodology. The *PI Expert* software uses more complex versions of these expressions containing additional parameters to account for non-ideal effects. Thus, results from the software may not exactly match the computations from expressions in this document.

This document assumes a non-doubled input configuration. *PI Expert* includes modified expressions for both doubler and non-doubler input configurations. To simplify the expressions, all outputs are assumed to operate in continuous conduction mode, consistent with the worst case design at maximum load. At lower load conditions it is possible for individual outputs to operate in discontinuous conduction mode.

The methodology begins with an explanation of the general converter topology. It then presents the design flow, showing the major tasks in a high level flowchart. After a review of the nomenclature and definitions of variables, it discusses the details of the design procedure. Rationale, assumptions and expressions are given to help the designer enter parameters and interpret results. A complete list of variables used in the expressions follows in Appendix A. Appendix B offers a procedure for hardware verification.

General Converter Topology

Figure 1 shows a typical single-ended forward converter using *TOPSwitch-GX*. Detail is focused on the primary side of the transformer because the circuits on the secondary are conventional and covered in other literature.

Resistors R_A and R_B set the under-voltage lockout threshold. Resistor network R_A , R_B , R_C , and R_D with capacitor C_{VS} adjusts the maximum duty ratio as a function of the input voltage. This methodology gives the procedure to determine proper values for the resistors and the capacitor.

Another key element in the use of *TOPSwitch-GX* is the primary clamp (C_{CP} , D1, VR1, VR2 and VR3 in Figure 10) which resets the transformer flux and limits the maximum drain voltage. This methodology assumes use of this Zener-capacitor clamp circuit. Guidance for selection of components for this particular clamp is included in this application note.

The topic of clamp circuits is deferred to a separate application note. Designers may choose to use their own clamp circuits with the restriction that **resonant clamps, (for example, LCD clamps–inductor/capacitor/diode) and reset windings are not recommended**. The internal current sense of *TOPSwitch-GX* does not allow the high reset current of a resonant clamp to be excluded from the sensed drain current.

This methodology uses an ordinary optically isolated feedback circuit that is common in voltage mode systems with a two-pole

response. The frequency compensation will in general require two zeros and two poles to obtain the phase margin desired for most applications. While the design of the feedback circuit is a separate topic beyond the scope of this application note, the general topology of the circuit is discussed.

Output Options

Salient features of the output circuits are illustrated in Figure 2. Multiple secondary windings of the transformer may be configured in many different ways to give several options for regulated and unregulated output voltages.

All applications will have only one main output. This is the voltage that is regulated directly by *TOPSwitch-GX* through the optically isolated feedback circuit. In general, any number of auxiliary outputs may be derived from other secondary windings and regulated indirectly by means of a coupled inductor that they share with the main output.

The secondary windings for the auxiliary outputs may be configured in two different ways. The conventional configuration connects one side of the auxiliary winding to the main output return. This connection is used when the auxiliary output is the opposite polarity of the main output. An alternative configuration, sometimes known as the DC stacked connection, has one side of the auxiliary winding referenced to the main output instead of the output return. It has the advantage of better regulation of the auxiliary output voltage than the non-stacked arrangement, but is limited to outputs that are greater in magnitude and of the same polarity as the main output voltage.

Any number of unregulated output voltages may be derived from circuits that do not share an inductor with any other outputs. They are related to the main output only through separate secondary windings on the transformer. Their inductors are independent of the others. These outputs typically are referenced to the output return, but alternatively they may be referenced to any potential that the isolation of the transformer will tolerate.

Multiple tightly regulated voltages may be obtained with either linear or switching post regulators. These external regulators may be added to any output, including the main output. They are simply additional loads on those output voltages.

A particularly useful type of switching post regulator is the magnetic amplifier, which uses a saturating magnetic element as an independently controlled switching device. While a magnetic amplifier can in theory be operated from any output, this methodology restricts the connection to the main output only.

Since it is not possible to treat every combination of output options in this presentation, the methodology will be restricted



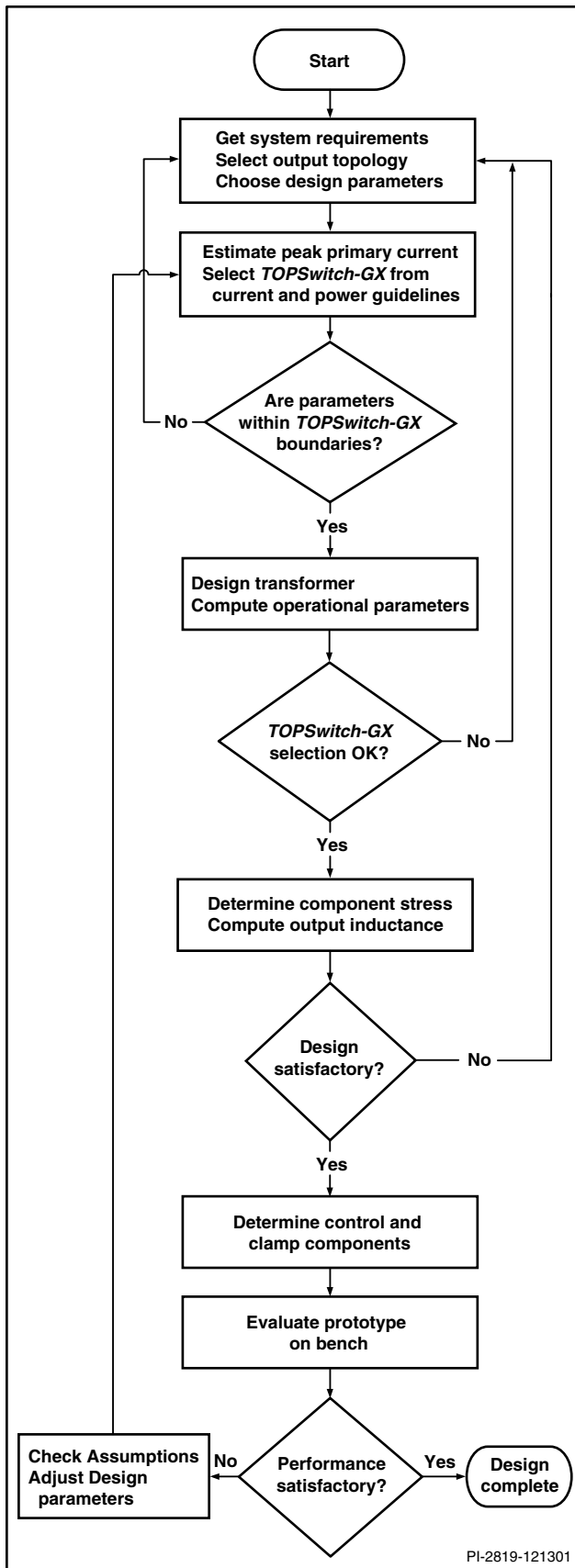

Figure 3. Flowchart Showing Major Tasks in the Design of Forward Converters with TOPSwitch-GX.

to those that are typical for power supplies in personal computers. Therefore, this methodology allows the following options:

- One main output
- A maximum of one auxiliary output that may be DC stacked to the main output or referenced to output return
- A maximum of one independent output
- A maximum of one magnetic amplifier post regulator that operates from the secondary winding for the main output
- Any number of linear post regulators that may operate from any output

Design Flow

Figure 3 is an abbreviated flowchart of the major tasks in the design methodology. The important decision blocks involve the selection of the proper *TOPSwitch-GX* device for the application, and the designer's satisfaction with the overall design.

All designs begin with the definition of requirements. The next section discusses the parameters a designer needs to know before the design can start.

Parameters for the forward converter are dominated by the output specifications. The designer will have to choose a topology that is appropriate for the application. An application that calls for only one output is simplest, while a requirement for several outputs with complex loading needs careful consideration. It may be necessary to go through several designs to select the most satisfactory configuration.

Knowledge of system requirements and selection of the output topology allow the designer to compute the magnetic parameters. These are turns ratios for the transformer and the coupled inductor (if the design has an auxiliary output), plus values of inductance for independent outputs and the output inductor for the magnetic amplifier (also called mag amp). The output inductor for the mag amp is different from the inductive switching element (sometimes called a saturable reactor, saturable core, or saturable choke), that is not addressed in this note.

The peak primary current can be computed from the turns ratios established for the transformer along with the ripple current in the output inductors. This allows selection of the appropriate *TOPSwitch-GX*. It must have sufficient current limit to handle the maximum steady-state load and must have enough additional margin to accommodate peak loads and transients. Another consideration in the selection of the *TOPSwitch-GX* is power dissipation in the device. A device that can handle the steady-state and peak primary currents does not guarantee ability to meet thermal limitations – this is an independent consideration.

The efficiency of the power system is an important consideration in every design. The designer should have a goal for the efficiency of the system at the start of the design, based on reasonable allowances for power lost in the specific areas of the power supply.

The efficiency goal should take into account losses in the transformer, inductors, output rectifiers, and clamp circuits. Most high power designs have some form of power factor correction (PFC). The type of PFC will affect the efficiency. For example, the voltage drop on a passive PFC (a large inductor in series with the AC line input) will reduce the minimum input voltage at the converter, and will also reduce system efficiency.

Total system efficiency should consider losses in the AC input circuit, including the EMI filter, that are not part of this design methodology. Only a bench evaluation can determine the actual efficiency of the power supply. If the efficiency is not satisfactory, the designer must revise the values of component parameters or change the output topology for a repeat design.

If the requirements call for a holdup time, the designer must determine the amount of bulk input capacitance that is required to achieve the specified holdup time from the designated input voltage. It is often necessary to adjust parameters by iteration to meet the objectives of the design.

PI Expert performs the calculations to allow the designer to see the interactions of the variables immediately.

After the values of the major power components are determined, the designer needs to check voltage and current stress to select components with the proper ratings. Then the designer can choose values for small signal components that set voltage detection thresholds and other control parameters.

The final step is an evaluation of a prototype on the bench. This is the only way to confirm that the design is satisfactory, and to get necessary information to adjust the parameters if a redesign is necessary.

Definition of Variables

Table 1 gives a set of system parameters that should be known at the start of the design. The list is general, so all the parameters will not necessarily be relevant to all applications. Some values will be given by the system specification, while others are the designer's choice.

The notation in this document uses descriptive subscripts to keep track of variables. Quantities that refer to the main output are designated with the subscript _{MAIN}. Variables associated with an auxiliary output are identified by the subscript _{AUX}, and those related to an independent output have the subscript _{IND}.

Name	Description
η	Total system efficiency
f_L	AC mains frequency
f_S	<i>TOPSwitch-GX</i> switching frequency
I_{AUX}	Current from auxiliary output
I_{IND}	Current from independent output
I_{MAIN}	Current from main output
I_{MAINMA}	Current from magnetic amplifier
t_H	Holdup time
V_{ACMAX}	Maximum AC input voltage
V_{ACMIN}	Minimum AC input voltage
V_{ACNOM}	Nominal AC input voltage
V_{ACUV}	AC under-voltage threshold
V_{AUX}	Auxiliary output voltage
V_{AUXREF}	Auxiliary output reference voltage
$V_{DROPOUT}$	Lowest DC bus voltage for regulation
V_{DSOP}	Maximum drain-to-source voltage
V_{HOLDUP}	DC bus voltage at start of t_H
V_{IND}	Independent output voltage
V_{MAIN}	Main output voltage
V_{MAINMA}	Magnetic amplifier output voltage

Table 1. System Parameters Needed to Start a Design.

These conventions are used to identify voltages, currents, and components.

When there is more than one output in a category, the individual members are distinguished by numbers appended to the subscript, as in _{IND1}, _{IND2} and _{IND3} for three independent outputs. Quantities related to the magnetic amplifier have _{MA} appended to the subscript, as in _{MAINMA} referring to the magnetic amplifier on the secondary winding for the main output. This notation has the generality necessary to expand the allowable output options.

Turns ratios on magnetic components are designated by lower case n with appropriate subscripts, while actual numbers of turns are distinguished by upper case N with identifying subscripts.

There are a few other variables and notations that need definition. Figure 4 shows a section of output circuitry that identifies some important electrical quantities. Each output of a forward converter has two diodes. One is designated the forward diode and the other is the catch diode. Associated quantities have _F or _C appended to their respective subscripts.



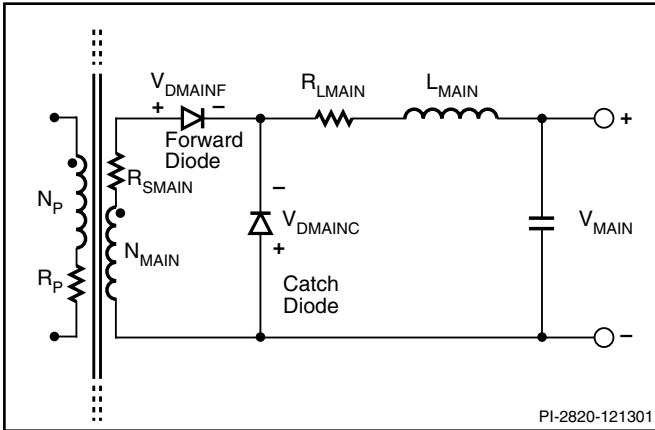

Figure 4. Output Circuit with Parameter Definitions.

Voltage drops on diodes have subscripts with the prefix $_d$ for the conduction drop and $_{piv}$ for the reverse blocking voltage. The only exception to this convention is for drain-to-source voltages, which will be obvious from context.

Figure 4 also shows series resistances that the designer can include to get better predictions of performance.

Detailed Design Procedure

This methodology guides the designer through a procedure that determines parameters for prototype hardware. After bench evaluation, the designer refines the parameters to meet all requirements.

The design can start with knowledge of only the most basic system requirements. For example, the forward voltage drops on diodes and the resistances of transformer windings are seldom known very accurately at the beginning of a new design. Results of the design with default values will guide the designer to select particular components with known parameters. Figure 5 gives an expanded flowchart that includes the detailed steps which follow.

Step 1. Establish system requirements.

Determine the parameters in Table 1. These should be available from a system specification of the power supply's application.

The software will compute and display the maximum and minimum DC bus voltages to the converter from the AC inputs. The need to know maximum and minimum voltages is obvious. The optional nominal input voltage V_{ACNOM} helps determine the turns ratios of the transformer. The goal is to set the unregulated output voltages at their nominal values when the input is at its nominal value. The designer may choose any value between V_{ACMAX} and V_{ACMIN} to be the nominal value.

The peak DC bus voltage (non-doubled) is

$$V_{MAX} = V_{ACMAX} \sqrt{2} \quad (1)$$

while the DC bus voltage at the valley of the ripple at the minimum steady state AC input is

$$V_{MIN} = \sqrt{2V_{ACMIN}^2 - \frac{2P_o \left(\frac{1}{2f_L} - t_c \right)}{\eta_{DC} C_{IN}}} \quad (2)$$

where P_o is the total output power, t_c is the conduction time of the bridge rectifier, η_{DC} is the efficiency exclusive of losses in the AC input circuit, and C_{IN} is the capacitance at the input to the converter. Use 3 ms for t_c and use the total system efficiency η for η_{DC} if no better estimates are available. A good initial value for C_{IN} is 1 μ F per watt multiplied by P_o .

The designer should carefully choose the value of t_c when using passive PFC input (a large inductor in the AC line), since this approach significantly increases the diode conduction time. Also, the voltage waveform will deviate from a sinusoid, causing some error in the prediction of Equations (1) and (2).

Remember to use the input voltage to linear regulators, not the regulated output voltage, to compute the total output power. The dissipation in the linear regulator is part of the load on the converter.

The nominal DC bus voltage is defined to be

$$V_{NOM} = \frac{\sqrt{2}}{2} \left[V_{ACNOM} + \sqrt{V_{ACNOM}^2 - \frac{P_o \left(\frac{1}{2f_L} - t_c \right)}{\eta_{DC} C_{IN}}} \right] \quad (3)$$

This is simply the midpoint between the peak and valley of the ripple voltage on the input capacitor (non-doubled).

Step 2. Set ripple current in the output inductors.

Choose the ripple current factor $K_{\Delta I}$. Figure 6 shows how it is related to the average output current. $K_{\Delta I}$ is a useful parameter for design because it directly influences the size of the output inductor. It also affects the peak primary current and the RMS current in the output capacitors.

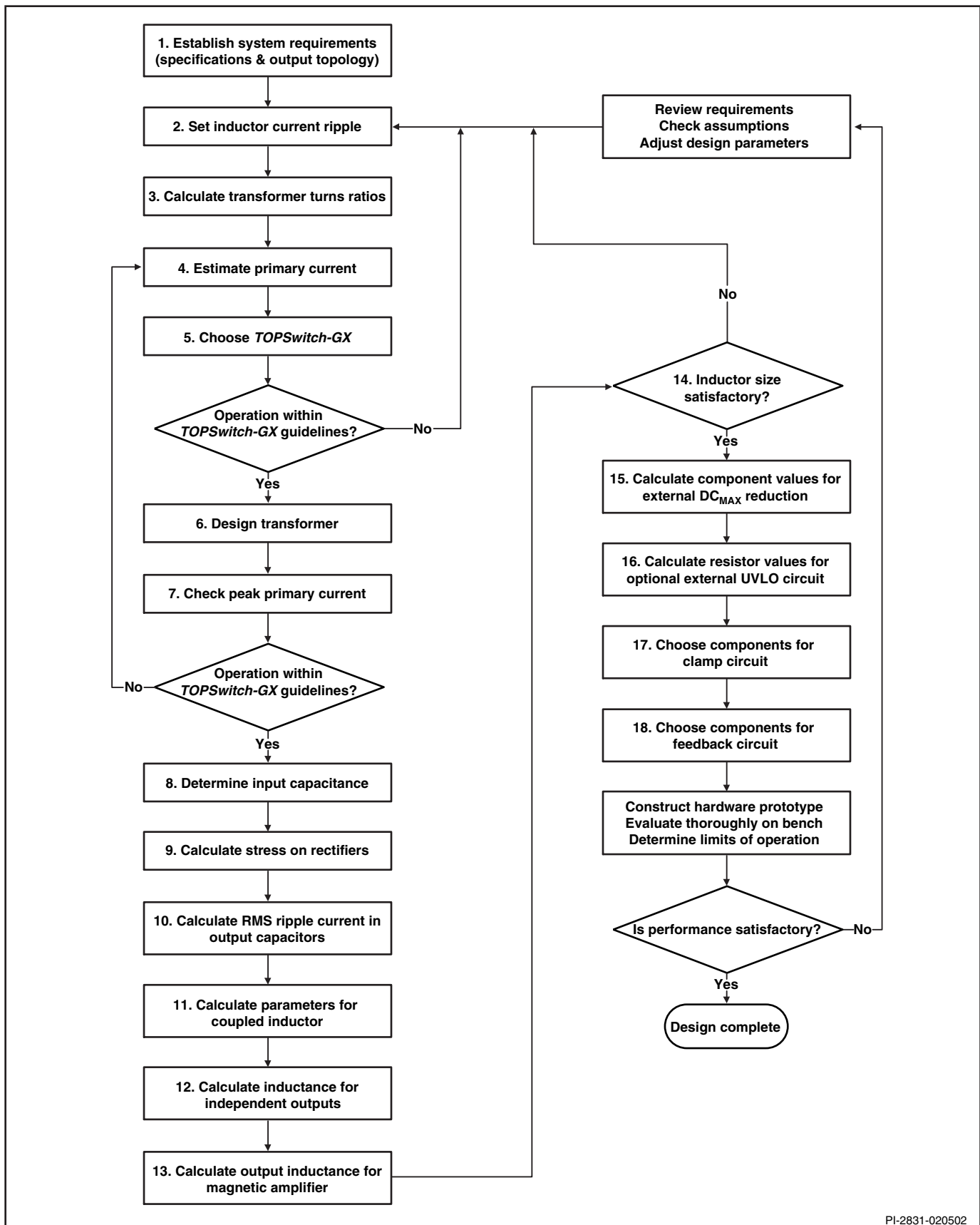

PI-2831-020502

Figure 5. Expanded Flow Chart Showing Detailed Steps in Forward Design Methodology.



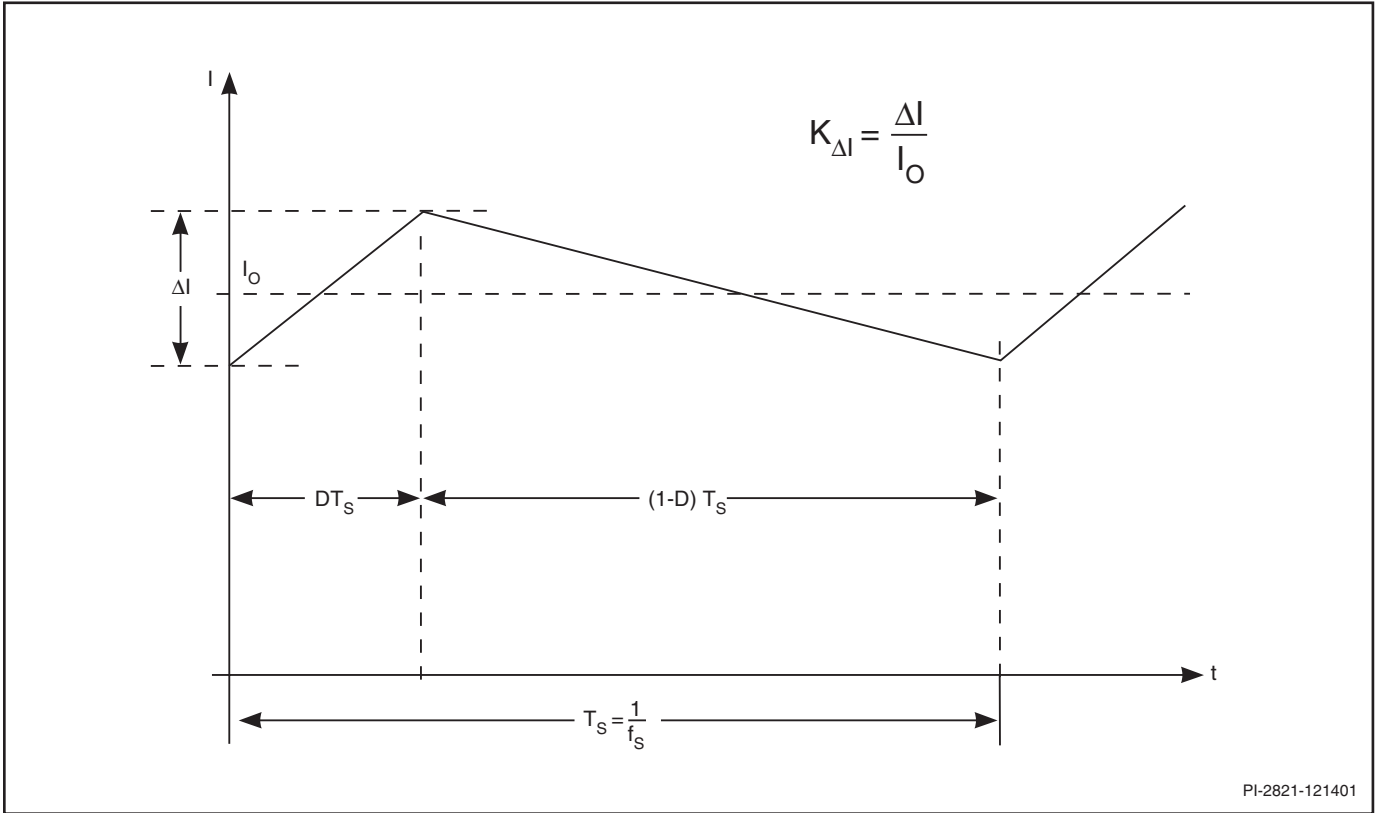

Figure 6. Inductor Current Showing Definition of $K_{\Delta I}$.

The ripple current in the inductor depends on the converter's operating point. In general, $K_{\Delta I}$ will change with the duty ratio according to the relationship

$$K_{\Delta I} = K_{\Delta I0}(1 - D) \quad (4)$$

where $K_{\Delta I0}$ is the limit as the duty ratio approaches zero. The expression that relates $K_{\Delta I0}$ to the inductance L for a given generic output is

$$K_{\Delta I0} = \frac{V_{\text{OUTPUT}} + V_{D(\text{OUTPUT})C}}{LI_{\text{OUTPUT}}f_s} \quad (5)$$

where $V_{D(\text{OUTPUT})C}$ is the voltage on the catch diode when it is conducting.

$K_{\Delta I}$ will be between 0.15 and 0.3 for most practical designs. The $K_{\Delta I}$ corresponding to the highest input voltage is used for calculations. All dependent quantities should then be computed for the designer's inspection. Since the duty ratio at the highest input voltage will usually be very small, $K_{\Delta I0}$ is usually a very good approximation to the worst case $K_{\Delta I}$.

If any outputs have nonzero minimum load, use the minimum load as a guide for the upper limit on $K_{\Delta I}$. The best regulation

across multiple outputs at minimum load is obtained when

$$K_{\Delta I} \leq 2 \left(\frac{I_{\text{MINIMUM}}}{I_{\text{MAXIMUM}}} \right) \quad (6)$$

where I_{MINIMUM} and I_{MAXIMUM} are the respective minimum and maximum average output currents.

The common $K_{\Delta I}$ at full load allows calculation of the inductance. The designer has the option to change any value of any inductor to suit particular requirements. The change in inductance will change the $K_{\Delta I}$ for that particular inductor.

For coupled inductors, $K_{\Delta I}$ indicates the ripple component of the total ampere turns, not ripple current on any individual winding.

Step 3. Calculate turns ratios for the transformer.

Turns ratios on the transformer are computed with respect to the main output winding. The primary-to-main turns ratio is fixed by the input and output voltages and the maximum duty ratio, which is limited by the maximum drain-to-source voltage that is set by the designer. The maximum duty ratio to guarantee reset of the transformer is

$$D_{\text{MAX_RESET}} \leq 1 - \frac{V_{\text{DROPOUT}}}{V_{\text{DSOP}}} \leq 0.74 \quad (7)$$

where $V_{DROPOUT}$ is the DC bus voltage at the end of the holdup time and V_{DSOP} is the maximum drain-to-source voltage on the *TOPSwitch-GX* during operation. The minimum recommended value for $V_{DROPOUT}$ is 130 V, while V_{DSOP} is usually less than the breakdown voltage of 700 V by a comfortable safety margin. A safety margin of 15% is typical, giving 600 V for V_{DSOP} .

The maximum duty ratio for the converter occurs at $V_{DROPOUT}$. This must be reduced as a function of line voltage from the DC_{MAX} of *TOPSwitch-GX* by external circuitry in Step 15. The recommended maximum duty ratio D_{MAX} for the forward converter application depends on the operating input voltage range. For a 3:1 operating range ($V_{MAX}:V_{DROPOUT}$) 70% is typical. As the operating range reduces so does the value of D_{MAX} . For a 2:1 operating range a value of 50% would be selected.

First, compute the turns ratios for the primary and the auxiliary winding. The turns ratio on the primary of the transformer is

$$n_P = \frac{V_{DROPOUT} - V_{DS}}{(V_{MAIN} + V_{DMAINC}) \left(\frac{1 - D_{MAX}}{D_{MAX}} \right) + V_{MAIN} + V_{DMAINF}} \quad (8a)$$

Where V_{DS} is the average drain-to-source voltage during the on-time of *TOPSwitch-GX*:

When V_{DMAINF} and V_{DMAINC} are the same value V_{DMAIN} , this equation simplifies to:

$$n_P = \frac{(V_{DROPOUT} - V_{DS}) D_{MAX}}{V_{MAIN} + V_{DMAIN}} \quad (8b)$$

The turns ratio for the auxiliary winding is

$$n_{AUX} = \frac{V_{AUX} + V_{DAUXC} - V_{AUXREF}}{V_{MAIN} + V_{DMAINC}} \quad (9)$$

Equation (8) is valid for systems where the leakage inductance of the transformer is negligible. This is a reasonable assumption because the leakage inductance must be minimized for low power dissipation and proper operation of the clamp circuit. Leakage inductance reduces the effective duty ratio on the secondary circuits by delaying the turn-off of the catch diodes. The effect can be significant in designs with very high output currents. To compute the turns ratio for the primary winding when leakage inductance is a consideration, subtract the constant

$$\delta_D = \frac{L_{MAINLK} I_{MAINSEC}}{V_{MAIN}} D_{MAX} f_S \quad (10)$$

from D_{MAX} in Equation (8). In Equation (10), L_{MAINLK} is the leakage inductance of the secondary winding of the main output, $I_{MAINSEC}$ is the winding current required to turn off the catch diode of the main output, and f_S is the switching frequency. Note that in the DC stacked connection for the auxiliary output, the winding for the main output carries the current of the main output plus the current of the stacked auxiliary outputs.

Next, compute the duty ratio D_{NOM} that corresponds to the nominal input voltage.

$$D_{NOM} = \frac{V_{MAIN} + V_{DMAINC}}{\frac{V_{NOM}}{n_P} - V_{DMAINF} + V_{DMAINC}} \quad (11)$$

This allows a better estimate of the turns ratio that will produce the desired independent output voltage.

$$n_{IND} = \frac{V_{IND} + V_{DINDF} D_{NOM} + V_{DINDC} (1 - D_{NOM})}{V_{MAIN} + V_{DMAINF} D_{NOM} + V_{DMAINC} (1 - D_{NOM})} \quad (12)$$

Finally, compute the turns ratio for the bias winding so that the bias voltage is greater than eight volts. This value is the CONTROL pin voltage, 5.8 V, plus the 2.2 V saturation voltage of the optocoupler's phototransistor at $V_{DROPOUT}$.

The turns ratio for the bias winding is then

$$n_B \geq n_P \left(\frac{8 \text{ volts} + V_{DB}}{V_{DROPOUT}} \right) \quad (13)$$

where $V_{DROPOUT}$ is the minimum DC bus voltage for regulation and V_{DB} is the voltage drop on the rectifier for the bias voltage. Check that the breakdown voltage on the phototransistor of the optocoupler is higher than the bias voltage at the highest transient input voltage.

Step 4. Calculate the primary current.

Find the peak and RMS values for the primary current. This is a preliminary estimate from the system parameters. It allows the designer to assess the suitability of his application for *TOPSwitch-GX* as early as possible.

Figure 7 shows typical primary current waveforms for forward converters with and without a magnetic amplifier post regulator. Figure 7(a) is without a magnetic amplifier, whereas Figure 7(b) shows the effect of one magnetic amplifier post regulator. *TOPSwitch-GX* determines the duty ratio D to regulate the main output, whereas the post regulator sets D_{MA} independently by its own local feedback to regulate the output voltage from the magnetic amplifier.



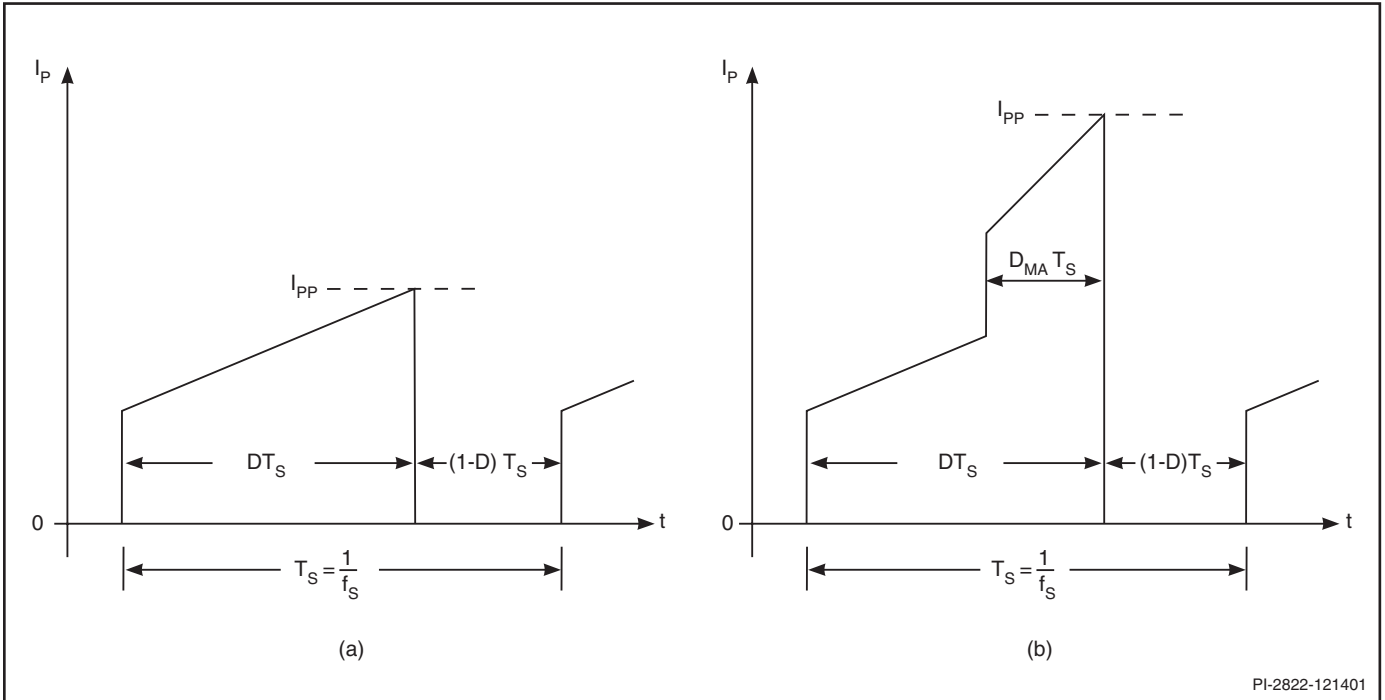

Figure 7. Typical Primary Current Waveforms for a Converter Without Magnetic Amplifier (a) and with a Mag Amp (b).

The computation is simply the reflection of peak currents in the secondary circuits by the ideal turns ratios of the transformer. Using the principle that the sum of the ampere turns for an ideal transformer is zero, the instantaneous primary current for a transformer with W secondary windings is just

$$I_P = \frac{1}{n_P} \sum_{j=1}^W i_j n_j \quad (14)$$

where i_j is the current in the secondary winding with turns ratio n_j . Thus, for a transformer with three secondary windings, the primary current would be the sum $i_1 n_1 + i_2 n_2 + i_3 n_3$ divided by the turns ratio of the primary. Note that since all turns ratios are defined with respect to the main output winding, the turns ratio of the main output winding is 1. Equation (14) may also be used with the actual number of primary turns N_P substituted for the turns ratio n_P , and the actual secondary turns N_j substituted for the turns ratios n_j .

This estimate does not include the effect of magnetizing current in the transformer, which will be determined after the transformer is designed. The magnetization current will raise the peak value of this estimate by typically less than 10% worst case.

The computation in *PI Expert* includes the ripple current in the output inductors to find the peak primary current. Ripple current is ignored to calculate the RMS value. The resulting error in the RMS current is less than 1% for practical values of

inductance and current. The RMS current is computed at the duty ratio that corresponds to V_{ACMIN} because worst case steady-state resistive losses occur at that operating point.

Step 5. Choose the appropriate TOPSwitch-GX device.

Select a *TOPSwitch-GX* according to the requirements for peak primary current and acceptable power dissipation. For operation of the converter in continuous conduction mode it is recommended to operate the device at no more than 80% of its current limit for ordinary thermal design. To reduce device dissipation it is possible to use a *TOPSwitch-GX* device that has a lower $R_{DS(ON)}$ when the current limit is adjusted accordingly. Lowering I_{LIMIT} externally (using a programming resistor to the X pin), takes advantage of the lower $R_{DS(ON)}$ of the larger device while maintaining the same level of overload protection.

The external current limit reduction factor is

$$K_I = \frac{\text{External Current Limit}}{\text{Data Sheet Current Limit}} \quad (15)$$

where $0.4 \leq K_I \leq 1.0$, and is set by the value of a resistor connected between the X pin and SOURCE pin. Refer to the *TOPSwitch-GX* data sheet for details.

With external current limit reduction, the actual (external) current limit is

$$I_{XLIMIT} = I_{LIMIT} K_I \quad (16)$$



Remember to check the maximum and minimum tolerance on I_{LIMIT} from the data sheet for the selected device. Allow margin to guarantee that the peak primary current I_{PP} is less than the minimum value of I_{XLIMIT} at high temperature. With minimum device I_{LIMIT} , check that

$$I_{PP} \leq 0.96 I_{LIMIT} \text{ for } K_I = 1 \quad (17)$$

$$I_{PP} \leq 0.86 I_{XLIMIT} \text{ for } K_I < 1$$

Adjust the system specifications if the peak current is too high for the largest device. While some specifications are fixed, others are adjustable at the discretion of the designer. Raising the minimum input voltage will give lower peak current.

Step 6. Design the transformer.

The transformer design can be either completed in-house or delegated to a qualified supplier of custom magnetics. An outside supplier needs to know the turns ratios and the recommended restrictions on flux density to start a design. Even if the ultimate design will be done outside, it is beneficial to do a rough design in-house. A proposed design with actual numbers of turns on each winding will reduce the time required to obtain a satisfactory transformer.

The maximum recommended flux density for this application is

$$B_{PEAK} \leq 0.3 \text{ tesla (3000 gauss)} \quad (18)$$

and the recommended maximum change in flux density per switching period (AC flux density) is

$$B_M \leq 0.2 \text{ tesla (2000 gauss)} \quad (19)$$

The constraint on B_M sets the minimum number of turns for a particular core, while the limit on B_{PEAK} restricts the maximum transient duty ratio. Although peak flux density under steady-state conditions can be calculated, the designer should allow sufficient margin to avoid saturation under transient conditions.

To start the design, select a core that is likely to meet the size and efficiency requirements of the application. Since the voltages and turns ratios are determined, all that remains is to find the actual number of turns and the size of wire for each winding.

Compute the minimum turns for the main output.

$$N_{MAIN} \geq \frac{V_{MAIN} + V_{DMAINF}}{B_M A_e f_s} \quad (20)$$

where A_e is the effective area of the core. Units in the above expression are volts, tesla, meter² and hertz. Round N_{MAIN} upward to the next integer value.

Compute the turns for the other power windings.

$$N_P = n_P N_{MAIN}$$

$$N_{AUX} = n_{AUX} N_{MAIN} \quad (21)$$

$$N_{IND} = n_{IND} N_{MAIN}$$

Round N_P downward to the next integer. Round N_{AUX} and N_{IND} to the nearest integer.

Compute the turns for the bias winding.

$$N_B = N_P \left(\frac{8 \text{ volts} + V_{DB}}{V_{DROPOUT}} \right) \quad (22)$$

Round N_B upward to the nearest integer value.

Designers should use copper foil instead of wire for windings of few turns that carry high current. It is very important to the success of the design to minimize leakage inductance.

Compute an estimate of the peak magnetizing current.

The primary inductance in henries is

$$L_P = \frac{\mu_0 A_e N_P^2}{\frac{\ell_e}{\mu_r} + \ell_g} \quad (23)$$

where μ_0 is the permeability of free space, A_e is the effective area, ℓ_e is the effective path length in the core and ℓ_g is the length of the air gap (see Zero Gap Transformer section). The dimensionless relative permeability μ_r is given by

$$\mu_r = \frac{A_L \ell_e}{400\pi A_e} \quad (24)$$

Units in the above two expressions are the SI basic units with the exception of inductance coefficient A_L , which has the conventional units of nH/turn².

With no gap, the primary inductance in henries is simply

$$L_{P|NO\ GAP} = A_L N_P^2 \times 10^{-9} \quad (25)$$

Now the peak magnetizing current is given by

$$I_{MP} = \frac{V_{MIN} D_{MAX}}{L_P f_s} \quad (26)$$

Units in the above expression are amperes, volts, henries and hertz. The magnetizing current should be less than 10% of the primary current for reasonable power dissipation in the clamp circuit.



Estimate the power lost in the core from the manufacturer's data on the core material, operating frequency and B_M . Copper losses may be estimated from the resistance and RMS current in each winding. If the estimates indicate excessive loss, repeat the design with a larger core.

Zero Gap Transformers

For highest efficiency in this application with the simple Zener clamp circuit, it is recommended that the transformer core have no air gap. While an air gap reduces the remnant flux density and stabilizes the primary inductance, it increases the stored energy that must be processed by the clamp circuit.

With the use of a suitable reset scheme, transformer saturation is not a problem in the absence of an air gap. Using this methodology and the recommended clamp scheme, the design restricts peak flux density and the clamp circuit produces negative magnetizing current during reset.

The negative magnetizing current during reset prevents flux build-up in the transformer during successive switching periods. Even with no intentional gap in the transformer core, mechanical imperfections will always give a finite effective gap (when calculating with *PI Expert* a value of 0.02 mm is used). If an air gap is desired for other reasons, it should be as small as possible.

Step 7. Check primary current.

Use the actual number of turns from the design of the transformer to compute the peak and RMS current on the primary. Primary current was estimated in Step 4 with an ideal turns ratio before the transformer was designed. Add the peak of the magnetizing current to obtain actual peak of the primary current under steady-state conditions.

Designers should be aware that the primary current observed on prototype hardware may be lower than predicted because the circuit that resets the flux in the transformer allows a negative average magnetizing current, as mentioned previously in Step 6 in the section on Zero Gap Transformers. The design, however, must allow for conditions when the magnetizing current adds to the reflected secondary currents.

Step 8. Determine the input capacitance for holdup time.

The holdup time must be specified at a minimum voltage V_{HOLDUP} . This is often, but not always V_{MIN} . For maximum flexibility, this methodology allows the designer to determine the value of input capacitance required to obtain a given holdup time from an arbitrary input voltage.

If a DC voltage is specified to mark the beginning of the holdup time, the minimum required input capacitance is

$$C_{IN} \geq \frac{2P_O t_H}{\eta_{DC} (V_{HOLDUP}^2 - V_{DROPOUT}^2)} \quad (27)$$

where P_O is the total output power that corresponds to the efficiency at the DC bus, η_{DC} and t_H is the holdup time.

If an AC voltage $V_{ACHOLDUP}$ is specified to mark the beginning of the holdup time, the minimum required input capacitance (no doubler) is

$$C_{IN} \geq \frac{2P_O}{\eta_{DC}} \left(\frac{2(t_H - t_C) + \frac{1}{f_L}}{2V_{ACHOLDUP}^2 - V_{DROPOUT}^2} \right) \quad (28)$$

where t_C is the conduction time of the AC input rectifiers and f_L is the frequency of the AC power line. Again, note that t_C will increase significantly if the design has passive PFC.

The efficiency η_{DC} excludes losses in the AC input circuit and EMI filter. No power is dissipated in the AC input circuit during the holdup time because the AC input is disconnected. The lower system efficiency η that includes the AC input losses would give a value of C_{IN} that is larger than required.

Compare the value from Equation (27) or (28) with the estimate for C_{IN} in Step 1. Adjust C_{IN} in Step 1 and repeat the calculations until the computed value is approximately the same as in Step 1.

Step 9. Calculate stress on rectifiers.

PI Expert calculates voltage and current stress on rectifiers for guidance in selection of appropriate components. The recommended derating factor for peak inverse voltage is 80%. Derating for the currents is generally not necessary.

Thus, the recommended voltage rating for the input bridge rectifier is

$$V_{PIVAC} = 1.25\sqrt{2}V_{ACMAX} \quad (29)$$

Current ratings for rectifiers are average values, not RMS. The current rating for the bridge rectifier is computed from

$$I_{DAVBR} = \frac{P_O}{\eta_{DC} V_{LL}} \quad (30)$$

where V_{LL} is the average DC bus voltage at the lowest steady-state line voltage (no doubler).

$$V_{LL} = \frac{\sqrt{2}}{2} \left[V_{ACMIN} + \sqrt{V_{ACMIN}^2 - \frac{P_O \left(\frac{1}{2f_L} - t_C \right)}{\eta_{DC} C_{IN}}} \right] \quad (31)$$



Calculations of the peak inverse voltage on the output rectifiers use V_{MAX} , V_{DSOP} , and the output voltages with the turns on the transformer windings.

Calculations of worst case average current in the catch diodes are with the duty ratio that corresponds to the maximum input voltage. A very good approximation to the average rectifier current is then just the output current. Current in the forward diodes is computed with D_{MAX} . Note that with DC stacked outputs, the rectifiers on the main output must conduct the sum of the currents of the main and auxiliary outputs.

In general, the stress will be different for the forward diode and the catch diode on the same output. Designers will have to consider the one with the greater stress when choosing components that contain both diodes in the same package.

Step 10. Calculate RMS ripple currents in output capacitors.

Currents in the output capacitors are computed at the maximum loads. In continuous conduction mode, the RMS ripple current is given by

$$I_{RMS} = \frac{K_{\Delta I} I_{OUTPUT}}{2\sqrt{3}} \quad (32)$$

where $K_{\Delta I}$ is for the particular output under consideration. This expression is reliable for independent outputs and for a main output with no coupled inductors. For converters with auxiliary outputs, Equation (32) is only an estimate. Ripple currents in the individual windings of coupled inductors depend on magnetic coupling coefficients, parasitic voltage drops, and other quantities in the circuit that are difficult to predict. Therefore, designers must evaluate prototype hardware on the bench to confirm that the assumptions of the design are valid for a particular application.

Step 11. Calculate parameters for the coupled inductor.

The coupled inductor allows the auxiliary outputs to have better regulation than independent outputs, with the penalty of increased complexity of the inductor.

PI Expert allows two options for the topology of the auxiliary output. The auxiliary output may be referenced to the main output voltage for the best regulation or to output return when necessary. The reference must be at output return to obtain a negative auxiliary output with a positive main output.

Turns ratios for the coupled inductor are the same as the ratios for the transformer. The turns ratio of a coupled inductor for a converter that has one auxiliary output is, in terms of the actual number of turns,

$$\frac{N_{LMAIN}}{N_{LAUX}} = \frac{N_{MAIN}}{N_{AUX}} \quad (33)$$

Inductance is computed for the winding that is on the main output. The computation is based on $K_{\Delta I}$, which considers the total ampere turns of the coupled inductor, not just the current in one winding. The inductance of the winding for the main output, valid for only the DC stacked configuration, is

$$L_{MAIN} = \frac{V_{MAIN} + V_{DMAINC}}{K_{\Delta I} \left(I_{MAIN} + I_{AUX} \left(\frac{N_{LAUX}}{N_{LMAIN}} + 1 \right) \right) f_S} \quad (34)$$

PI Expert gives the designer the turns ratio, the total ampere turns, and the peak energy stored in the inductor. The designer has the option to change these parameters by adjustment of the $K_{\Delta I}$ for each inductor.

These quantities assist the designer to obtain an appropriate inductor of either his own design or one from a qualified supplier. Bench evaluation of the prototype will determine if fine adjustment of the turns is necessary in the final configuration.

Step 12. Calculate inductance for independent outputs.

Calculation of the inductance for independent outputs is straightforward and similar to the computation of the parameters for the coupled inductor. Design of the component is simplified because there is no turns ratio associated with an inductor that has only one winding. *PI Expert* computes the inductance and the peak stored energy. This information is useful for selection of magnetic cores from catalogs.

Step 13. Calculate output inductance for the magnetic amplifier.

PI Expert computes the output inductor for a magnetic amplifier post regulator in the same way as for an independent output. It does not address the magnetic switching element.

Step 14. Adjust output inductors if necessary.

The designer may modify the $K_{\Delta I}$ of any inductor to accommodate special requirements. If the value or the estimated physical size of the computed inductor is not satisfactory, adjust the individual $K_{\Delta I}$ to achieve the desired result.

Step 15. Calculate component values for external reduction of DC_{MAX} .

The maximum duty ratio (DC_{MAX}) of *TOPSwitch-GX* must be restricted to avoid saturation of the transformer during transient loading. A network of four resistors and a capacitor (R_A , R_B , R_C , V_Z , R_D and C_{VS} in Figure 1 and Figure 1 of Appendix B) determines a variable upper limit on the duty ratio. Adjustment of the maximum duty ratio with input voltage allows enough deviation beyond the steady-state operating point to respond to transients while maintaining enough time in every switching cycle for the transformer to reset.



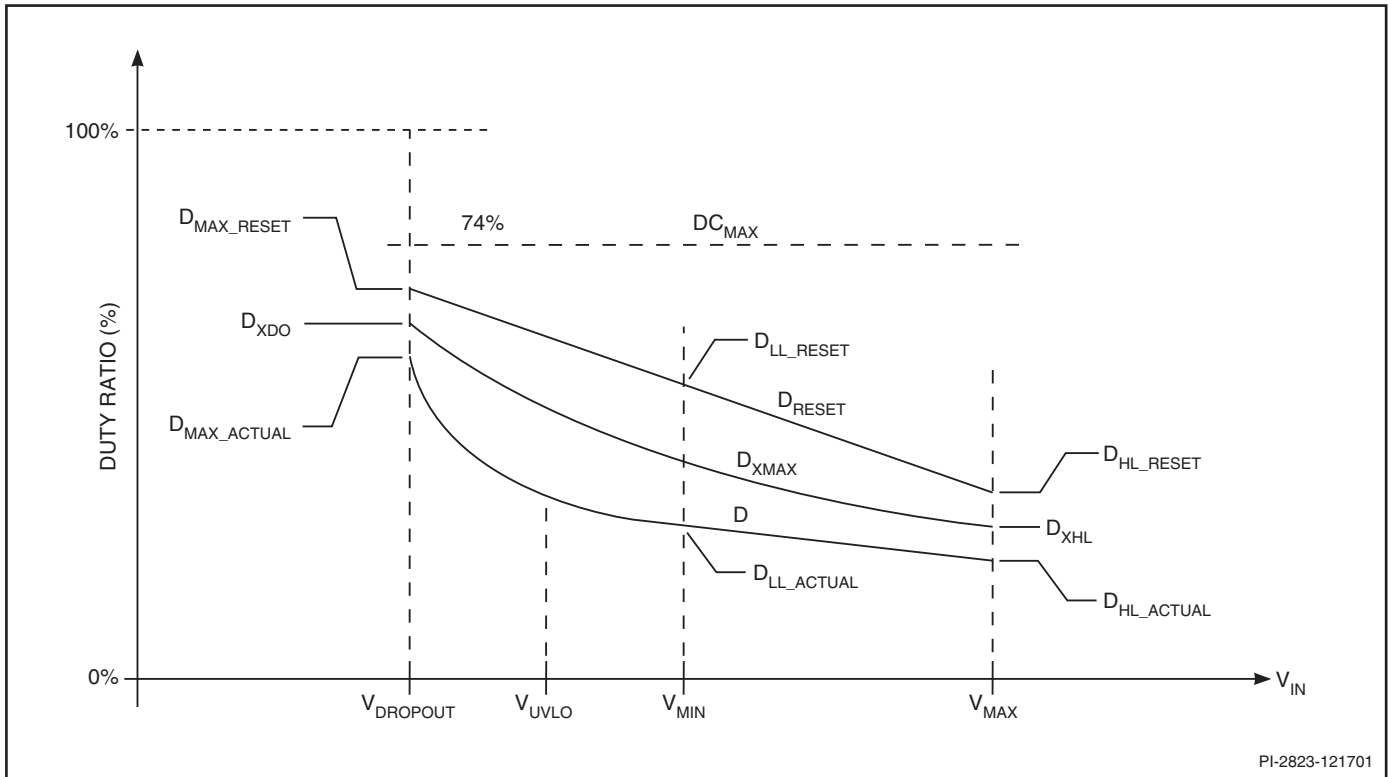

PI-2823-121701

Figure 8. Boundaries of Voltages and Duty Ratio Related to the Selection of R_A , R_B , R_C and R_D with C_{VS} in Figure 1.

The resistor network also sets the threshold for line under-voltage lockout. Protection from over-voltage is generally not a concern for this topology since it uses a Zener clamp to provide a hard limit on the drain-to-source voltage.

The resistors are matched to the capacitor to form an integrator with an appropriate time constant to give a cycle-by-cycle duty ratio limit. The integration of the voltage on the bias winding gives the external duty ratio limit a desirable relationship to the flux in the transformer. The circuit adjusts the duty ratio limit to set an upper bound on the volt-second product, and to balance the volt-second product during *TOPSwitch-GX* on and off times. The dynamic nature of the circuit allows greater freedom and precision in the design without interference from the line over-voltage threshold limit.

Figure 1 shows the locations of resistors R_A , R_B , R_C and R_D with capacitor C_{VS} . Several important quantities related to their values are illustrated in Figure 8. The broken vertical lines in Figure 8 mark the boundaries of the DC bus voltage for minimum and maximum operating voltages, the line under-voltage lockout threshold, and the lowest input voltage that will guarantee regulation of the output.

The broken horizontal line shows the maximum guaranteed duty cycle of *TOPSwitch-GX*. A value of 74% is recommended for design.

The lowest curve is the duty ratio D that corresponds to steady-state operation at a given input voltage. The straight line with negative slope is the maximum duty ratio D_{RESET} that will still guarantee reset of the transformer for a given V_{DSOP} . The converter must always operate with D less than D_{RESET} to avoid saturation of the transformer. The curved line between the D and D_{RESET} lines is the external duty ratio limit D_{XMAX} that is set by the resistors.

The designer must choose the components to set the curve of D_{XMAX} at a desired position between the boundaries of D_{RESET} and D for a given set of specified voltages.

PI Expert prompts the user to enter several parameters that are important to the computation of the resistor values. Some parameters are from the *TOPSwitch-GX* data sheet while others are design choices. The software suggests default and typical values. The designer can enter maximum and minimum values to check worst case situations.

The components are calculated to satisfy the constraints of four parameters: D_{XDO} (external duty ratio limit at $V_{DROPOUT}$), D_{XHL} (external duty ratio limit at V_{MAX}), V_{UVLO} (input voltage where the *TOPSwitch-GX* starts switching), and the maximum transient input voltage V_{OV} that is greater than V_{MAX} .

While there are four resistors, only three are unknown because R_A and R_B are identical by definition. They are connected in series to keep the voltage across each one below its maximum rating. The three unknown resistors and one capacitor make four unknown quantities that are determined by the four constraints.

Figure 8 illustrates the general case where D_{XDO} is between the actual duty ratio D_{MAX_ACTUAL} and D_{MAX_RESET} at the input voltage $V_{DROPOUT}$. If the converter is not required to respond to transient loads at the end of the holdup time, D_{XDO} and D_{MAX_ACTUAL} can be set to D_{MAX_RESET} . Since response to transient loads is usually required at V_{MAX} , the designer will want to set D_{XHL} at a comfortable margin between D_{HL_ACTUAL} and D_{HL_RESET} .

Begin with the computation of values for R_A and R_B to set the line under-voltage threshold V_{ACUV} .

$$R_A = R_B = \frac{V_{ACUV} \sqrt{2}}{2I_{UV}} \quad (35)$$

where V_{ACUV} is the AC input voltage (non-doubled) required for the converter to start, and I_{UV} is the line under-voltage threshold current of the L pin of *TOPSwitch-GX* from the datasheet. Choose the nearest standard resistor value for R_A and R_B .

Define intermediate variables to make the expressions easier to write and interpret.

$$m_{IL} \equiv \frac{D_{IL1} - D_{IL2}}{I_{L2} - I_{L1}} \quad (36)$$

$$I_{LD0} \equiv \frac{D_{IL}}{m_{IL}} + I_L \quad (37)$$

$$R_{AB} \equiv R_A + R_B \quad (38)$$

$$V_{BZL} \equiv V_{DB} + V_Z + V_L \quad (39)$$

In Equation (36), D_{IL1} and D_{IL2} are respectively the values of DC_{MAX} at currents I_{L1} and I_{L2} into the L pin. Obtain these values from the data sheet. (Note these are specified only for the TOP248-TOP250 devices.) Use the typical values at first. Then check that the circuit will perform properly at the high and low ends of the tolerance range.

In Equation (37), D_{IL} is the value of DC_{MAX} at current I_L into the L pin. Use the same D_{IL1} with I_{L1} or D_{IL2} with I_{L2} as in Equation (36). Either pair will give the same result. I_{LD0} has a physical interpretation that cannot be realized: if the duty ratio reduction characteristic continued along its linear slope, it would reach zero at the current I_{LD0} .

The voltages V_{DB} , V_Z and V_L are respectively the forward drop of the rectifier in series with the Zener diode and R_C , the Zener voltage, and the voltage on the L pin as shown in Figure 1. The Zener diode is chosen as required to raise the curve of D_{XMAX} at the low input voltages. It may not be necessary in all applications. The Zener voltage is 6.8 V in this example.

Next, select a value for D_{XHL} that is between D_{HL_ACTUAL} and D_{HL_RESET} .

$$D_{HL_ACTUAL} = \frac{V_{MAIN} + V_{DMAINC}}{(V_{MAX} - V_{DS}) \frac{N_S}{N_P} - V_{DMAINF} + V_{DMAINC}} \quad (40)$$

$$D_{HL_RESET} = 1 - \frac{V_{MAX}}{V_{DSOP}} \quad (41)$$

Find the range of permissible values for D_{XDO} . To compute the upper and lower bounds on D_{XDO} , define the intermediate variable K_{XDO} .

$$K_{XDO} \equiv m_{IL} \left(I_{LD0} - \frac{V_{MAX}}{R_{AB}} - \frac{D_{XHL}}{m_{IL}} \right) \left(\frac{V_{DROPOUT} \frac{N_B}{N_P} - V_{BZL}}{V_{MAX} \frac{N_B}{N_P} - V_{BZL}} \right) \quad (42)$$

The upper bound for D_{XDO} is then

$$D_{XDO} < m_{IL} \left(I_{LD0} - \frac{V_{DROPOUT}}{R_{AB}} \right) - K_{XDO} \quad (43)$$

and the lower bound for D_{XDO} is

$$D_{XDO} > \frac{m_{IL} \left(I_{LD0} - \frac{V_{DROPOUT}}{R_{AB}} \right)}{1 + \frac{K_{XDO}}{D_{XHL}}} \quad (44)$$

Choose an appropriate value for D_{XDO} between D_{MAX_RESET} and D_{MAX_ACTUAL} that also satisfies the boundaries of (43) and (44).

Next, compute the intermediate constants r_1 and r_2 .

$$r_1 \equiv \frac{\left(V_{DROPOUT} \frac{N_B}{N_P} - V_{BZL} \right) D_{XDO}}{I_{LD0} - \frac{V_{DROPOUT}}{R_{AB}} - \frac{D_{XDO}}{m_{IL}}} \quad (45)$$

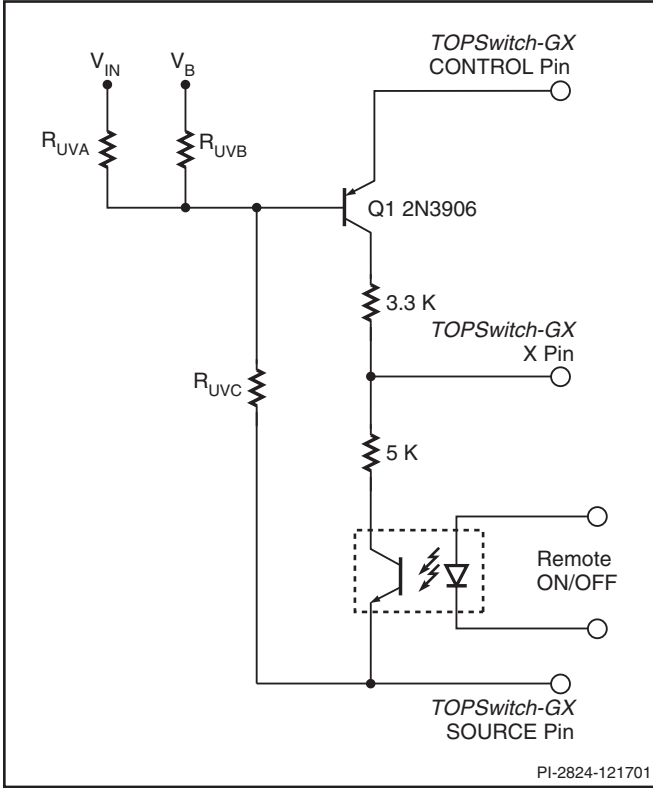

Figure 9. External Under-Voltage Lockout Circuit.

$$r_2 \equiv \frac{\left(V_{MAX} \frac{N_B}{N_P} - V_{BZL} \right) D_{XHL}}{I_{LD0} - \frac{V_{MAX}}{R_{AB}} - \frac{D_{XHL}}{m_{IL}}} \quad (46)$$

Compute the values for the resistors R_D and R_C .

$$R_D = \frac{r_1 - r_2}{D_{XDO} - D_{XHL}} \quad (47)$$

$$R_C = r_1 - D_{XDO} R_D \quad (48)$$

Select the nearest standard resistor values for R_C and R_D .

Verify that the parameters are within the desired range with the actual component values.

$$V_{ACUV} = \frac{I_{UV}}{\sqrt{2}} (R_A + R_B) \quad (49)$$

This is the AC input voltage (non-doubled) where the converter will begin to operate.

The external duty ratio limit at any DC bus voltage V_{IN} may be computed from the expression

$$D_{MAX} = \frac{v_B + \sqrt{v_B^2 + 4v_A v_C}}{2v_A} \quad (50)$$

where

$$v_A = \frac{R_D}{m_{IL}} \quad (51)$$

$$v_B = V_{BZL} + I_{LD0} R_D - \frac{R_C}{m_{IL}} - V_{IN} \left(\frac{R_D}{R_{AB}} + \frac{N_B}{N_P} \right) \quad (52)$$

$$v_C = R_C \left(I_{LD0} - \frac{V_{IN}}{R_{AB}} \right) \quad (53)$$

Now choose an appropriate value for the capacitor. Proper choice of the capacitor allows the converter to operate safely with transient input voltages greater than V_{MAX} . The line overvoltage feature of *TOPSwitch-GX* is not used in the conventional fashion in this application. The circuit operates in an over-voltage mode that reduces the maximum duty ratio further by reduction of the switching frequency. The value of the capacitor C_{VS} is chosen to give the desired behavior in the over-voltage mode.

Select an input voltage V_{OV} greater than V_{MAX} that marks the onset of over-voltage operation. Then compute the maximum duty ratio D_{XOV} that corresponds to the specification in the *TOPSwitch-GX* data sheet for the Line Over-Voltage Threshold Current I_{OV} .

$$D_{XOV} = D_{IL} - m_{IL} (I_{OV} - I_L) \quad (54)$$

Here D_{IL} , m_{IL} and I_L are the same as in Equations (36) and (37).

Finally, compute the capacitor value as

$$C_{VS} = \frac{\left(I_{OV} - \frac{V_{OV}}{R_{AB}} \right) \left((1 - D_{XOV}) T_S - t_{R(ON)} \right)}{K_{OVHYS} I_{OVHYS} R_D} \quad (55)$$

where

- T_S is the switching period $1/f_s$ in normal operation
- $t_{R(ON)}$ is the Remote ON Delay
- I_{OVHYS} is the hysteresis of the IOV threshold
- K_{OVHYS} is a constant selected by the designer.

The first three parameters are taken from the data sheet. The constant K_{OVHYS} is selected to provide sufficient ripple voltage



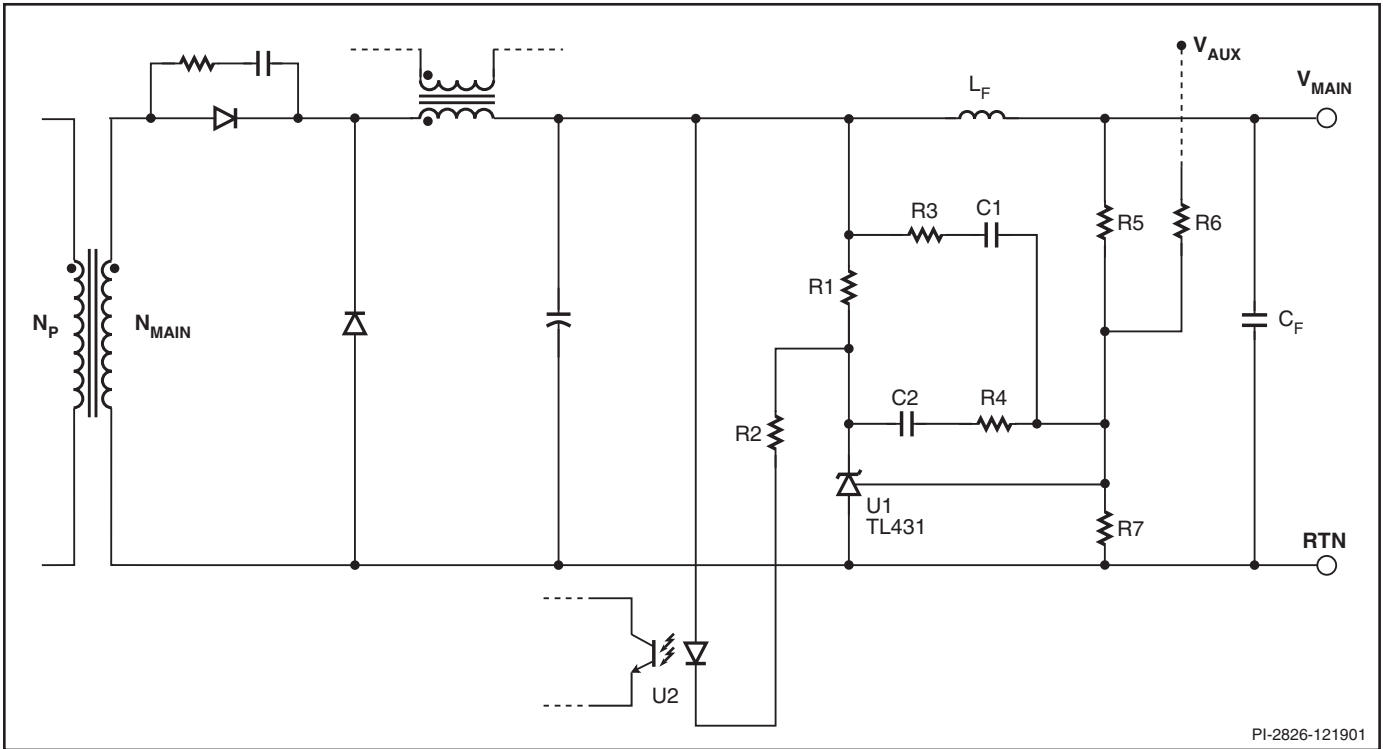

PI-2826-121901

Figure 11. General Configuration of Feedback Circuit for Forward Converter with TOPSwitch-GX.

$$V_{UVL} = \frac{v_1 \left(\frac{R_{UVB}}{R_{UVC}} + 1 \right)}{\frac{R_{UVB}}{R_{UVA}} + \frac{N_B}{N_P}} \quad (64)$$

$$V_{ACUVL} = \sqrt{\frac{V_{UVL}^2}{2} + \frac{P_o \left(\frac{1}{2f_L} - t_c \right)}{\eta_{DC} C_{IN}}} \quad (65)$$

$$V_{ACUVX} = \frac{v_1}{\sqrt{2}} \left(1 + \frac{R_{UVA}}{R_{UVC}} \right) \quad (66)$$

If V_{ACUVL} and V_{ACUVX} are not satisfactory, adjust the values of the resistors.

Step 17. Choose components for the clamp circuit.

Figure 10 shows connections for the elements of a Zener clamp circuit that is suitable for many applications. Capacitor C_{CP} , diode D1 and the string of Zener diodes are on the primary side of the transformer. Resistor R_{CS} and capacitor C_{CS} are on the secondary side of the transformer.

This arrangement limits the voltage on the drain of the TOPSwitch-GX to approximately the sum of the voltages of the string of Zener diodes. It also recovers most of the energy from leakage inductance and magnetization inductance, and returns it to the input or delivers it to the output.

Select the Zener diodes to limit the drain voltage to V_{DSOP} . Choose the voltage, size and number of diodes in the string to achieve the desired V_{DSOP} and to handle the power dissipation. This arrangement is adequate for applications where the clamp circuit dissipates less than 5 W.

Capacitor C_{CP} supplements the natural stray capacitance on the drain node to absorb energy that comes mostly from the leakage inductance. The value must be selected empirically because it is difficult to predict natural stray capacitance and leakage inductance accurately enough to calculate a proper value. Energy not absorbed by the capacitance will be dissipated in the Zener string, so C_{CP} cannot be too small. If C_{CP} is too large, its voltage will change too slowly to allow the transformer to reset during transients. Typical values for C_{CP} are in the neighborhood of 2 nF.

Diode D1 must be a slow recovery type such as a 1N5407. The recovery of D1 removes enough charge from C_{CP} to stabilize its voltage and to discharge some of its stored energy into the primary of the transformer. This energy returns to the input on the next switching cycle.



The remaining components are connected across the forward diode on the main output. Energy from leakage inductance on the secondary and magnetization inductance of the transformer charges C_{CS} when the *TOPSwitch-GX* turns off. The energy from C_{CS} is delivered to the output during the next switching cycle. Resistor R_{CS} provides damping for oscillations that would otherwise occur from the resonance of C_{CS} with stray inductance.

Typical values are in the neighborhood of 0.1 μF for C_{CS} and 1 Ω for R_{CS} . The resistor must dissipate power that corresponds to the charge and discharge of C_{CS} each cycle. It typically will dissipate less than 1 watt. Proper values must be determined empirically from evaluation of prototype hardware.

Step 18. Choose components for the feedback circuit.

The pulse width modulator in *TOPSwitch-GX* sets the duty ratio according to the current into the CONTROL pin. *TOPSwitch-GX* senses the drain current for protection only, and does not use it for control purposes. Thus, forward converters with *TOPSwitch-GX* operate with a voltage-mode control that modulates the converter's duty ratio directly according to an error signal from the regulated output voltage. Voltage mode control provides sufficient loop bandwidth and is fully able to meet all the specifications for PC Main and other high power applications.

The general configuration of the feedback circuit for a forward converter with *TOPSwitch-GX* is illustrated in Figure 11. It shows a typical connection of a TL431 voltage regulator with an optocoupler and components for frequency compensation. There is an optional connection to V_{AUX} to improve the regulation of the auxiliary output by sharing regulation with the main output. This general technique is common in all types of multiple output regulators.

While the design of the feedback loop is beyond the scope of this application note, it is useful to consider the general circuit of Figure 11. The components are chosen to provide regulation of output voltages and to shape the frequency characteristics of the control loop. Proper design of the feedback components is important not only for the stability of the system, but also for transient response of the output.

Inductor L_F with capacitor C_F reduces high frequency noise on the main output. As such, it introduces phase shift in the small signal response that would make loop compensation difficult if the only feedback for the main output were taken from the voltage on C_F . To avoid difficulties with the feedback loop, information about the main output is taken from two places.

Low frequency information that is most important to the DC regulation comes mainly through the path formed by resistor divider of R5, R6 and R7. The voltage on R7 is the reference

voltage of the TL431 when V_{MAIN} and V_{AUX} are at their desired values.

High frequency information that is most important in the transient response comes through the path formed by the optocoupler's diode and R2. This same technique is commonly used with *TOPSwitch-GX* in flyback converter applications.

The values of R1, R3, R4, C1 and C2 are chosen to shape the frequency response. The choices are influenced by the components on the CONTROL pin and equivalent series resistance of the output capacitor, which can be important features of the loop gain. Designers must make proper measurements of loop gain and transient response on prototype hardware to confirm that the converter performs as desired under all specified conditions.

Evaluation of Prototype Hardware

The design that results from the steps of the previous section contains the uncertainties of the initial assumptions. Performance must be validated with measurements on prototype hardware before the design is complete.

At this stage in the procedure, the designer will have enough information to build a circuit that will operate at nominal conditions for evaluation on the bench. The designer must test the circuit at all the limits of specified performance. Measurements will indicate which changes to the original assumptions are necessary. A successful design is obtained after repetition of the procedure with parameters adjusted from measurements on the hardware.

The evaluation should include observation of the drain-to-source voltage on *TOPSwitch-GX* under steady state operation and transient conditions. Apply power to the converter slowly with minimum loads. Then exercise the loads on the outputs in different combinations, first at the nominal input voltage and then at the extremes of input voltage.

Observe the behavior at various static loads before going to transient loading. Check for excessive power dissipation in the clamp circuit. A useful technique is to monitor the average current in the string of Zener diodes in the clamp circuit with a low value resistor in series. A capacitor in parallel with the resistor will develop a voltage proportional to the average current through the diodes. The product of this voltage and the clamp voltage gives an indication of the power dissipation in the Zener diodes.

Monitor the drain current when the output has steady-state overload and during transient loading. The waveform will provide important information about the operation of the converter and the limits of the design. Check that the current

limit of the *TOPSwitch-GX* is sufficient for all the specified conditions.

Check that the transformer does not saturate under all steady-state combinations of line and load. Verify the proper design of the circuit to limit maximum duty ratio with the procedure in Appendix B.

Check the ripple on all the output voltages with several combinations of input voltage and output loading, particularly if the design uses a coupled inductor. Verify that the under-voltage thresholds are within design limits for startup and for shutdown.

Key Design Considerations

While the design of forward converters with *TOPSwitch-GX* has much in common with designs that use discrete transistors and controllers, some important differences must be considered. Attention to these items will significantly reduce the time to arrive at a successful design.

- A proper clamp circuit is required to control the maximum drain voltage. Resonant clamp circuits are not recommended. While the example clamp circuit in this document is suitable for moderate power levels, the circuit will need modification to adapt to applications that require the dissipation of more power.
- Leakage inductance of the transformer affects the power dissipation in the clamp circuit. High leakage inductance will prohibit the use of simple clamp circuits. Be aware that a magnetic amplifier post regulator will greatly increase the effective leakage inductance of the transformer.
- The primary inductance of the transformer affects the power dissipation in the clamp circuit. Maximize the primary inductance to reduce the magnetizing current and the energy that must be processed by clamp circuit.
- Use a slow diode for the rectifier D1 in the clamp circuit. A fast diode will greatly increase the amount of energy that the clamp must dissipate.
- Remember that the components R_{CS} and C_{CS} on the secondary are important components of the clamp circuit. Failure to include this network will cause excessive power dissipation in the clamp components on the primary.
- Confirm in bench evaluations that C_{CP} in the clamp circuit on the primary is not too large. Perform transient load tests at low and high input voltages. Monitor the drain voltage waveform for volt-second balance to be certain that the transformer does not saturate.
- Check the temperature of the Zener diodes VR1, VR2 and VR3 in the clamp circuit under maximum load at low input voltage and with repetitive transient loading. If the power supply does not have a latching shutdown for fault conditions, check it under a sustained short circuit on the output. There could be excessive heating if C_{CP} is too small, the primary inductance of the transformer is too low, or if the leakage inductance is too high.
- Match the current limit to the load. Use the X pin to program the current limit lower, especially if a larger *TOPSwitch-GX* is selected for thermal or efficiency reasons.

References

- [1] R. W. Erickson and D. Maksimović, *Fundamentals of Power Electronics*, Second Edition. Kluwer Academic Publishers, 2001. ISBN 0-7923-7270-0.
- [2] Colonel Wm. T. McLyman, *Transformer and Inductor Design Handbook*, Second Edition. Marcel Dekker, Inc., 1988. ISBN 0-8247-7828-6.
- [3] Colonel Wm. T. McLyman, *Magnetic Core Selection for Transformers and Inductors, A User's Guide to Practice and Specification*, Second Edition. Marcel Dekker, Inc, 1997. ISBN 0-8247-9841-4.
- [4] Colonel W. T. McLyman, *Designing Magnetic Components for High Frequency dc-dc Converters*. Kg Magnetics, Inc., 1993. ISBN 1-883107-00-8.
- [5] Micrometals Inc., 5615 E. La Palma Avenue, Anaheim, CA 92807 USA; www.micrometals.com.
- [6] MAGNETICS, P.O. Box 391, Butler, PA 16003-0391 USA, www.mag-inc.com.



Appendix A

Table of Nomenclature

Name in AN-30	Description
δ_D	Difference between actual and effective duty ratio that results from leakage inductance in the transformer.
η	Total system efficiency (lower case Greek letter eta).
η_{DC}	Efficiency excluding losses in AC input circuit and EMI filter. Used in computation of input capacitance required for holdup time. $\eta_{DC} \geq \eta$.
μ_0	Permeability of free space ($4\pi \times 10^{-7}$ H/m).
μ_r	Relative permeability of ferrite core material (lower case Greek letter mu). Dimensionless.
A_e	Effective cross-sectional area of transformer core.
A_L	Inductance coefficient of ungapped transformer core.
B_M	Maximum AC flux density in transformer core.
B_{PEAK}	Maximum flux density in the power transformer.
C_{IN}	Total bulk capacitance at the DC input to the converter.
C_{VS}	Capacitor in circuit for external reduction of DC_{MAX} .
D1	Diode in primary clamp circuit.
D	Duty ratio of <i>TOPSwitch-GX</i> at a given operating point.
D_{HL_ACTUAL}	Duty ratio at the highest operational DC input voltage V_{MAX} .
D_{HL_RESET}	Maximum duty ratio to guarantee reset of the transformer at DC input voltage V_{MAX} .
D_{IL}	Maximum duty ratio at current I_L .
D_{IL1}	The DC_{MAX} at current I_{L1} into the L pin of <i>TOPSwitch-GX</i> .
D_{IL2}	The DC_{MAX} at current I_{L2} into the L pin of <i>TOPSwitch-GX</i> .
D_{LL_ACTUAL}	Duty ratio at lowest steady state DC input voltage V_{MIN} .
D_{LL_RESET}	Maximum duty ratio to guarantee reset of the transformer at DC input voltage V_{MIN} .
D_{MA}	The duty ratio of the magnetic amplifier.
D_{MAX}	The maximum duty of <i>TOPSwitch-GX</i> at the lowest operational DC input voltage $V_{DROPOUT}$.
D_{MAX_ACTUAL}	Actual duty ratio of <i>TOPSwitch-GX</i> at the lowest operational DC input voltage $V_{DROPOUT}$.
D_{MAX_RESET}	Maximum duty ratio to guarantee reset of the transformer at DC input voltage $V_{DROPOUT}$. This is less than maximum duty cycle DC_{MAX} .
D_{NOM}	Duty ratio at nominal input voltage.
D_{RESET}	Maximum duty ratio to guarantee reset of the transformer at a given operating point.
D_{XDO}	Highest maximum duty cycle as set by current into the L pin of <i>TOPSwitch-GX</i> with external components. Occurs at DC input voltage $V_{DROPOUT}$.
D_{XHL}	The lowest maximum duty cycle as set by current into the L pin of <i>TOPSwitch-GX</i> with external components at DC input voltage V_{MAX} .
D_{XOV}	The maximum duty ratio that corresponds to I_{OV} .
DC_{MAX}	Maximum default duty cycle of <i>TOPSwitch-GX</i> (see Data Sheet).
f_L	AC line frequency.
f_S	<i>TOPSwitch-GX</i> switching frequency.
i_j	Instantaneous current in secondary winding j of the transformer.
I_{AUX}	Output current of the auxiliary output
I_{DAVBR}	Current rating for the bridge rectifier.
I_L	Current into the L pin of <i>TOPSwitch-GX</i> .

Name in AN-30	Description
I_{L1}	Current into the L pin of <i>TOPSwitch-GX</i> to give DC_{MAX} of D_{IL1} .
I_{L2}	Current into the L pin of <i>TOPSwitch-GX</i> to give DC_{MAX} of D_{IL2} .
I_{LD0}	Intermediate variable to compute values of components in circuit for external reduction of DC_{MAX} .
I_{MAIN}	Output current of the main output.
I_{MAINMA}	Output current of the magnetic amplifier on the secondary winding for the main output.
$I_{MAINSEC}$	Current in the secondary winding of the main output required to stop conduction of the main catch diode.
$I_{MAXIMUM}$	Maximum average output current for a specific output.
$I_{MINIMUM}$	Minimum average output current for a specific output.
I_{MP}	Peak value of the magnetizing current of the transformer referred to the primary winding.
I_{IND}	Output current of the independent output.
I_{OUTPUT}	Average current on a given output.
I_{OV}	Line over-voltage threshold current for the L pin of <i>TOPSwitch-GX</i> (see data sheet).
I_{OVHYS}	Hysteresis of the I_{OV} threshold (see data sheet).
I_P	Instantaneous current in the primary of the transformer.
I_{PP}	Peak current in the primary of the transformer.
I_{RMS}	RMS current in an output capacitor.
I_{UVHYS}	Hysteresis in line under-voltage threshold current (see data sheet).
I_{XLIMIT}	<i>TOPSwitch-GX</i> current limit with external current limit reduction.
K_I	External current limit reduction factor.
K_{AI0}	Maximum theoretical value of the ripple current factor for an output inductor, approached as D goes to zero.
K_{AI}	Ripple current factor for an output inductor at a given operating point.
K_{OVHYS}	Constant used to compute value of capacitor in circuit for external reduction of DC_{MAX} .
K_{XDO}	Intermediate variable to compute values of components in circuit for external reduction of DC_{MAX} .
l_e	Effective path length of transformer core.
l_g	Length of air gap in transformer core.
L_{MAIN}	Inductance of the coupled inductor measured at the winding for the main output with other windings open.
L_{MAINLK}	Leakage inductance of the transformer on the secondary winding for the main output.
L_{MAINMA}	Output inductor in the magnetic amplifier regulator on the secondary winding for the main output.
m_{IL}	Maximum Duty Cycle Reduction Slope (a positive number).
L_P	Inductance of the primary of the transformer with all other windings open.
n_{AUX}	Turns ratio of the auxiliary output winding with respect to the main output winding.
n_{IND}	Turns ratio of the independent output winding with respect to the main output winding.
n_j	Turns ratio of secondary winding j of the transformer with respect to the main output winding.
n_P	Turns ratio of the primary winding with respect to the main output winding.
N_j	Actual number of turns for secondary winding j on the transformer.
N_{AUX}	Number of turns for the auxiliary winding on the transformer.
N_B	Number of turns for the bias winding on the transformer.
N_{IND}	Number of turns for the independent winding on the transformer.
N_{MAIN}	Number of turns for the main output winding on the transformer.



Name in AN-30	Description
N_P	Number of turns for the primary winding on the transformer.
P_O	Total output power of the power supply.
P_{RUVA}	Power dissipation in the resistor R_{UVA} .
r_1	Intermediate variable to compute values of components in circuit for external reduction of DC_{MAX} .
r_2	Intermediate variable to compute values of components in circuit for external reduction of DC_{MAX} .
R_A	Resistor in the network that sets the line under-voltage threshold V_{ACUV} .
R_{AB}	Intermediate variable to compute values of components in circuit for external reduction of DC_{MAX} .
R_B	Resistor in the network that sets the line under-voltage threshold V_{ACUV} .
R_C	Resistor in circuit for external reduction of DC_{MAX} .
R_D	Resistor in circuit for external reduction of DC_{MAX} .
R_{LMAIN}	Resistance of the winding of the output inductor for the main output.
R_P	Resistance of the primary winding of the transformer.
R_{SMAIN}	Resistance of the secondary winding for the main output.
R_{UVA}	Resistor in optional external under-voltage lockout circuit.
R_{UVB}	Resistor in optional external under-voltage lockout circuit.
R_{UVC}	Resistor in optional external under-voltage lockout circuit.
t_C	Conduction time of the bridge rectifier.
t_H	Holdup time.
$t_{R(ON)}$	Remote ON Delay of <i>TOPSwitch-GX</i> . (See data sheet).
T_S	Switching period of <i>TOPSwitch-GX</i> , equal to $1/f_s$.
v_1	Intermediate variable to compute resistors in optional external under-voltage lockout circuit.
v_A	Intermediate variable to compute values of D_{XMAX} .
v_B	Intermediate variable to compute values of D_{XMAX} .
v_C	Intermediate variable to compute values of D_{XMAX} .
$V_{ACHOLDUP}$	Steady state AC input voltage that corresponds to the beginning of the holdup time.
V_{ACMAX}	Maximum steady-state AC input voltage.
V_{ACMIN}	Minimum steady-state AC input voltage.
V_{ACNOM}	AC input voltage where independent output voltages should be at their nominal values.
V_{ACUV}	Minimum AC input voltage where converter must start.
V_{ACUVL}	AC input voltage where the converter shuts off with optional external UVLO circuit.
V_{ACUVX}	AC input voltage where the optional external UVLO circuit enables the <i>TOPSwitch-GX</i> when input voltage is rising from zero.
V_{AUX}	Voltage on the auxiliary output.
V_{AUXREF}	Reference voltage for the auxiliary output in the DC stacked topology. This is usually V_{MAIN} .
V_{BZL}	Intermediate variable in the computation of components for DC_{MAX} reduction circuit.
V_{DAUXC}	Voltage drop on the catch diode of the auxiliary output when the diode is conducting.
V_{DB}	Voltage drop on the diode of the bias winding when the diode is conducting.
V_{DINDC}	Voltage drop on the catch diode of the independent output when the diode is conducting.
V_{DINDF}	Voltage drop on the forward diode of the independent output when the diode is conducting.
V_{DMAIN}	Voltage drop on the catch diode and the forward diode of the main output when the two are identical.

Name in AN-30	Description
V_{DMAINC}	Voltage drop on the catch diode of the main output when the diode is conducting.
V_{DMAINF}	Voltage drop on the forward diode of the main output when the diode is conducting.
$V_{DROPOUT}$	Lowest DC input voltage that will guarantee a regulated output.
V_{DS}	Average drain-to-source voltage on the <i>TOPSwitch-GX</i> during its on-time.
V_{DSOP}	Maximum drain-to-source voltage on the <i>TOPSwitch-GX</i> during operation.
V_{HOLDUP}	DC input voltage that marks the beginning of the holdup time t_H .
V_{IN}	Voltage on the bulk input capacitance C_{IN} .
V_{IND}	Voltage on the independent output.
V_L	Voltage on the L pin of <i>TOPSwitch-GX</i> with positive current.
V_{LL}	Average DC input voltage at V_{ACMIN} .
V_{MAX}	Maximum DC input voltage, equivalent to the peak value of V_{ACMAX} .
V_{MAIN}	Regulated DC voltage on the main output.
V_{MAINMA}	Regulated DC voltage from the magnetic amplifier derived from the secondary winding for the main output.
V_{MIN}	Valley of the rectified AC input voltage at V_{ACMIN} .
V_{NOM}	Nominal DC input voltage. Midpoint between peak and valley of the ripple voltage on C_{IN} when the AC input voltage is V_{ACNOM} .
V_{PIVAC}	Recommended voltage rating for the bridge rectifier.
V_{UVH}	DC input voltage corresponding to V_{ACUV} .
V_{UVL}	DC input voltage corresponding to V_{ACUVL} .
V_{UVLO}	Minimum DC input voltage for <i>TOPSwitch-GX</i> to start, set by resistor on from DC input voltage to L pin.
V_{UVX}	DC input voltage corresponding to V_{ACUVX} .
V_Z	Voltage of the Zener diode in the DC_{MAX} reduction circuit.
W	Number of secondary windings on the transformer.

Appendix B

Procedure for Verifying Duty Ratio Reduction Circuit

Predictions from analytic expressions are only as accurate as their inputs. It is always advisable to confirm the desired operation of circuits with actual hardware before they are released to production. Reduction of the maximum duty ratio of *TOPSwitch-GX* is particularly important in the forward converter application. Therefore, users are strongly advised to follow this simple procedure to confirm the correct operation of the circuit to reduce the maximum duty ratio.

Add the circuits and instrumentation as shown in Figures B1 and B2 to the forward converter under evaluation as described in the steps below. This setup allows independent adjustment

of the input voltage and the regulated main output voltage while monitoring the current into the L pin.

1. Connect the AC input section in the non-doubling configuration. Add enough extra bulk capacitance in parallel with C_{IN} to make the ripple voltage negligible. Alternatively, the converter may be operated from a high voltage DC power supply instead of from the AC source. Insert the parallel combination of a 100 Ω resistor and a 0.1 μF capacitor in series with the L pin. Monitor the voltage across the resistor with a digital voltmeter. Place a 1 k Ω resistor in each lead of the voltmeter to avoid interference from common

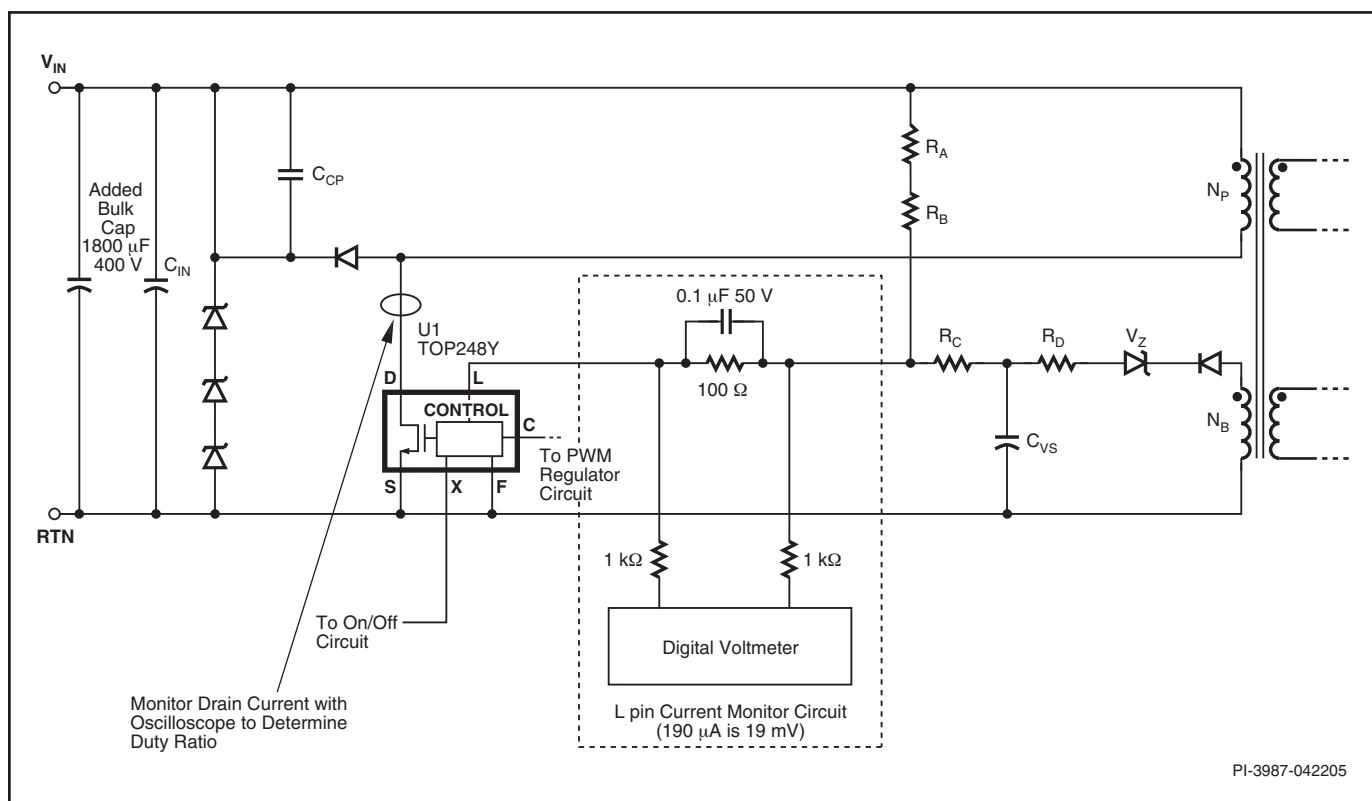

Figure B1. Setup to Measure Current into LINE-SENSE (L) Pin.

mode noise. Monitor the current in the DRAIN pin of *TOPSwitch-GX* with a current probe and an oscilloscope. Connect an adjustable low voltage DC power supply to the feedback circuit as shown in Figure B2.

2. Set the oscilloscope to read the duty ratio from the waveform of the *TOPSwitch-GX* drain current. Most digital oscilloscopes will provide a direct readout of the numerical value.
3. Adjust the low voltage DC power supply to 15 V.
4. Operate the converter at full load. Adjust V_{IN} to the value that corresponds to the duty ratio limit specified in the data sheet for a device at the low end of the tolerance range. The DC input voltage for these conditions is given by

$$V_{IN} = \frac{V_{BZL} + I_L \left(R_D + \frac{R_C}{D_{IL}} \right)}{\frac{N_B}{N_P} + \frac{1}{R_{AB}} \left(R_D + \frac{R_C}{D_{IL}} \right)} \quad (B1)$$

where D_{IL} is the minimum DC_{MAX} at the I_L of 190 μA , and the other terms are as they are defined in the text and Appendix A.

5. Adjust the duty ratio to D_{IL} by forcing the main output to regulate at a higher voltage. To do this, reduce the voltage of the bench power supply from 15 V until the duty ratio measured from the drain current is D_{IL} .
6. Verify that the current into the L pin is within 5% of I_L . The voltmeter should read 19 mV when I_L is 190 μA .

If it is not possible to adjust the circuit to meet these conditions, the circuit is not guaranteed to operate properly with all devices in the specified range of tolerance. Repeat the design with revised parameters.

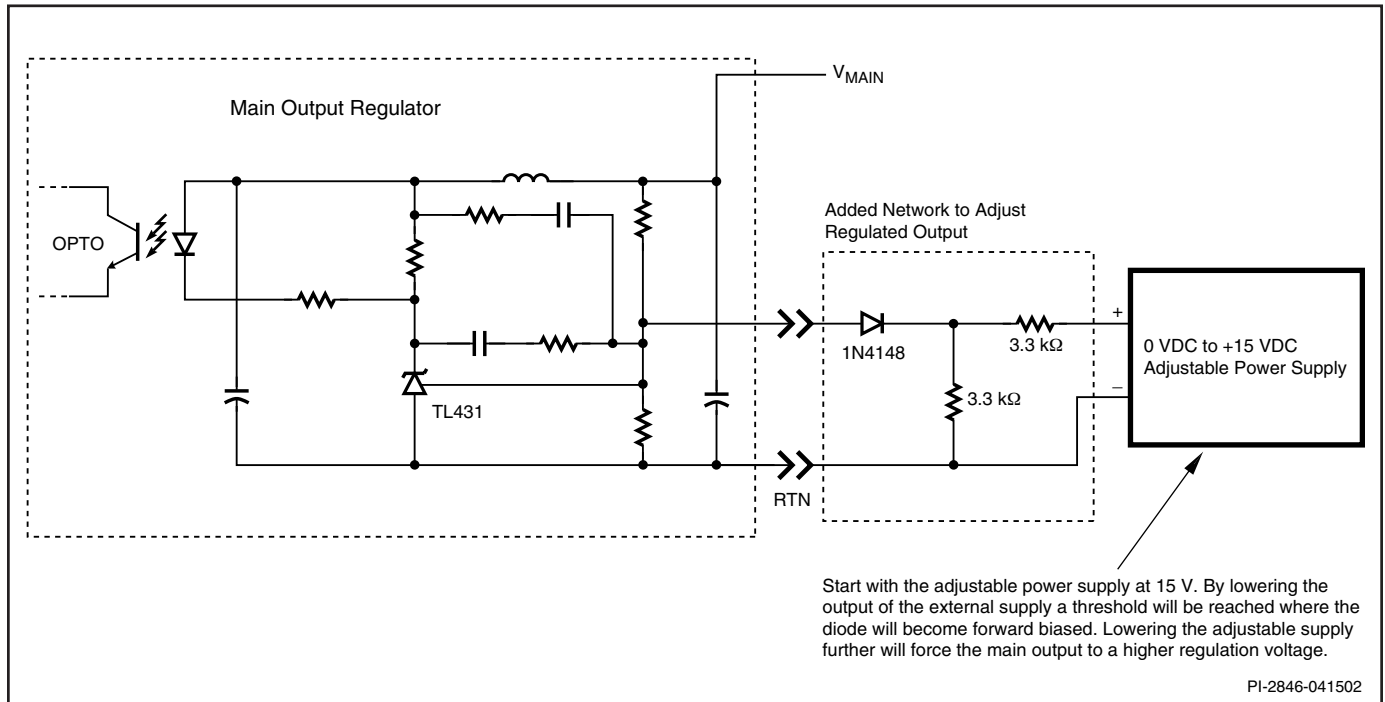

Figure B2. Circuit to Adjust Main Regulated Output Voltage to Higher Value.



Revision	Notes	Date
B	-	12/02
C	1) Simplified to TOP248-250.	4/05

For the latest updates, visit our Web site: www.powerint.com

Power Integrations reserves the right to make changes to its products at any time to improve reliability or manufacturability. Power Integrations does not assume any liability arising from the use of any device or circuit described herein. POWER INTEGRATIONS MAKES NO WARRANTY HEREIN AND SPECIFICALLY DISCLAIMS ALL WARRANTIES INCLUDING, WITHOUT LIMITATION, THE IMPLIED WARRANTIES OF MERCHANTABILITY, FITNESS FOR A PARTICULAR PURPOSE, AND NON-INFRINGEMENT OF THIRD PARTY RIGHTS.

PATENT INFORMATION

The products and applications illustrated herein (including transformer construction and circuits external to the products) may be covered by one or more U.S. and foreign patents, or potentially by pending U.S. and foreign patent applications assigned to Power Integrations. A complete list of Power Integrations' patents may be found at www.powerint.com. Power Integrations grants its customers a license under certain patent rights as set forth at <http://powerint.com/ip.htm>.

LIFE SUPPORT POLICY

POWER INTEGRATIONS' PRODUCTS ARE NOT AUTHORIZED FOR USE AS CRITICAL COMPONENTS IN LIFE SUPPORT DEVICES OR SYSTEMS WITHOUT THE EXPRESS WRITTEN APPROVAL OF THE PRESIDENT OF POWER INTEGRATIONS. As used herein:

1. Life support devices or system is one which, (i) is intended for surgical implant into the body, or (ii) supports or sustains life, and (iii) whose failure to perform, when properly used in accordance with instructions for use, can be reasonably expected to result in significant injury or death to the user.
2. A critical component is any component of a life support device or system whose failure to perform can be reasonably expected to cause the failure of the life support device or system, or to affect its safety or effectiveness.

The PI logo, **TOPSwitch**, **TinySwitch**, **LinkSwitch**, **DPA-Switch**, **EcoSmart**, **PI Expert** and **PI FACTS** are trademarks of Power Integrations, Inc. Other trademarks are property of their respective companies. ©Copyright 2005, Power Integrations, Inc.

Power Integrations Worldwide Sales Support Locations

WORLD HEADQUARTERS

5245 Hellyer Avenue
San Jose, CA 95138, USA.
Main: +1-408-414-9200
Customer Service:
Phone: +1-408-414-9665
Fax: +1-408-414-9765
e-mail: usasales@powerint.com

CHINA (SHANGHAI)

Rm 807-808A,
Pacheer Commercial Centre,
555 Nanjing Rd. West
Shanghai, P.R.C. 200041
Phone: +86-21-6215-5548
Fax: +86-21-6215-2468
e-mail: chinasales@powerint.com

CHINA (SHENZHEN)

Room 2206-2207, Block A,
Electronics Science & Technology Bldg.
2070 Shennan Zhong Rd.
Shenzhen, Guangdong,
China, 518031
Phone: +86-755-8379-3243
Fax: +86-755-8379-5828
e-mail: chinasales@powerint.com

GERMANY

Rueckertstrasse 3
D-80336, Munich
Germany
Phone: +49-89-5527-3910
Fax: +49-89-5527-3920
e-mail: eurossales@powerint.com

INDIA

261/A, Ground Floor
7th Main, 17th Cross,
Sadashivanagar
Bangalore, India 560080
Phone: +91-80-5113-8020
Fax: +91-80-5113-8023
e-mail: indiasales@powerint.com

ITALY

Via Vittorio Veneto 12
20091 Bresso MI
Italy
Phone: +39-028-928-6000
Fax: +39-028-928-6009
e-mail: eurossales@powerint.com

JAPAN

Keihin tatemono 1st Bldg 2-12-20
Shin-Yokohama, Kohoku-ku,
Yokohama-shi, Kanagawa ken,
Japan 222-0033
Phone: +81-45-471-1021
Fax: +81-45-471-3717
e-mail: japansales@powerint.com

KOREA

RM 602, 6FL
Korea City Air Terminal B/D, 159-6
Samsung-Dong, Kangnam-Gu,
Seoul, 135-728, Korea
Phone: +82-2-2016-6610
Fax: +82-2-2016-6630
e-mail: koreasales@powerint.com

SINGAPORE

51 Newton Road,
#15-08/10 Goldhill Plaza,
Singapore, 308900
Phone: +65-6358-2160
Fax: +65-6358-2015
e-mail: singapore@powerint.com

TAIWAN

5F, No. 318, Nei Hu Rd., Sec. 1
Nei Hu Dist.
Taipei, Taiwan 114, R.O.C.
Phone: +886-2-2659-4570
Fax: +886-2-2659-4550
e-mail: taiwansales@powerint.com

EUROPE HQ

1st Floor, St. James's House
East Street, Farnham
Surrey, GU9 7TJ
United Kingdom
Phone: +44 (0) 1252-730-140
Fax: +44 (0) 1252-727-689
e-mail: eurossales@powerint.com

APPLICATIONS HOTLINE

World Wide +1-408-414-9660

APPLICATIONS FAX

World Wide +1-408-414-9760

