

# InnoSwitch4-QR Family

Off-Line CV/CC QR Flyback Integrated Switcher IC with  
750 V PowiGaN and Synchronous Rectification

## Product Highlights

### Highly Integrated, Compact Footprint

- Quasi-Resonant (QR) operation for high efficiency
- Robust 750 V PowiGaN™ primary switch
- Steady-state switching frequency up to 155 kHz minimizes transformer size
- Synchronous rectification driver and secondary-side sensing
- Integrated FluxLink™, HIPOT-isolated, feedback link
- Precise CV/CC accuracy, independent of external components
- Accurate, adjustable output current sense using external sense resistor

### EcoSmart™ – Energy Efficient

- Up to 95% efficient
- Less than 30 mW no-load consumption including line sense

### Advanced Protection / Safety Features

- Open SR FET-gate detection
- Fast input line UV/OV protection
- Output overvoltage and undervoltage protection
- Output over-current protection
- Over-temperature protection (OTP)

### Optional Features

- Variable output voltage and constant current profiles
- Auto-restart or latching fault response for output OVP/UVP
- Multiple output UV fault thresholds
- Latching or hysteretic over-temperature protection

### Full Safety and Regulatory Compliance

- Reinforced isolation >4000 VAC
- 100% production HIPOT testing
- UL1577 (4000 VAC maximum isolation voltage), TUV (EN62368-1), CQC (GB4943.1) safety approved
- Excellent noise immunity enables designs that achieve class "A" performance criteria for EN61000-4 suite; EN61000-4-2, 4-3 (30 V/m), 4-4, 4-5, 4-6, 4-8 (100 A/m) and 4-9 (1000 A/m)

### Green Package

- Halogen free and RoHS compliant

### Applications

- High density flyback designs up to 220 W
- High efficiency CV/CC power supplies
- High efficiency USB PD adapters

### Description

The InnoSwitch™4-QR family of ICs dramatically improve the efficiency of flyback power converters, particularly those requiring a compact form-factor. The InnoSwitch4-QR family incorporates primary and secondary controllers, PowiGaN power switch and safety-rated feedback (FluxLink) into a single IC.

The InnoSwitch4-QR IC also incorporates multiple protection features including output overvoltage and over-current limiting, and over-temperature shutdown. Devices are available that support combinations of latching and auto-restart protection modes typically required for applications such as chargers, adapters, consumer electronics and industrial systems.

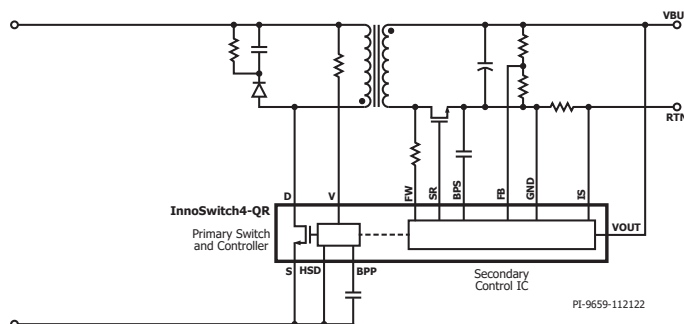

Figure 1. Typical Application schematic.



Figure 2. High Creepage, Safety-Compliant InSOP-24D Package.

## Output Power Table<sup>1</sup> – QR Mode

Product <sup>4,5</sup>	230 VAC ± 15%		85-265 VAC	
	Adapter <sup>2</sup>	Open Frame <sup>3</sup>	Adapter <sup>2</sup>	Open Frame <sup>3</sup>
<b>INN4274C</b>	80 W	90 W	65 W	85 W
<b>INN4275C</b>	90 W	100 W	75 W	90 W
<b>INN4276C</b>	105 W	125 W	80 W	115 W
<b>INN4277C</b>	125 W	145 W	90 W	135 W
Product <sup>4,5</sup>	385 VDC (PFC Input)			
	Adapter <sup>2</sup>		Open Frame <sup>3</sup>	
<b>INN4774C</b>	145 W		170 W	
<b>INN4775C</b>	155 W		180 W	
<b>INN4776C</b>	170 W		200 W	
<b>INN4777C</b>	185 W		220 W	

Table 1. Output Power Table.

Notes:

1. Maximum output power is dependent on the design, with maximum IC package temperature kept <125 °C.
2. Minimum continuous power in a typical non-ventilated enclosed typical size adapter measured at 40 °C ambient.
3. Minimum peak power capability.
4. C Package: InSOP-24D.
5. INN42xx series optimized for universal AC input designs.  
INN47xx series optimized for peak power designs with PFC input.



Figure 3. Primary Controller Block Diagram.

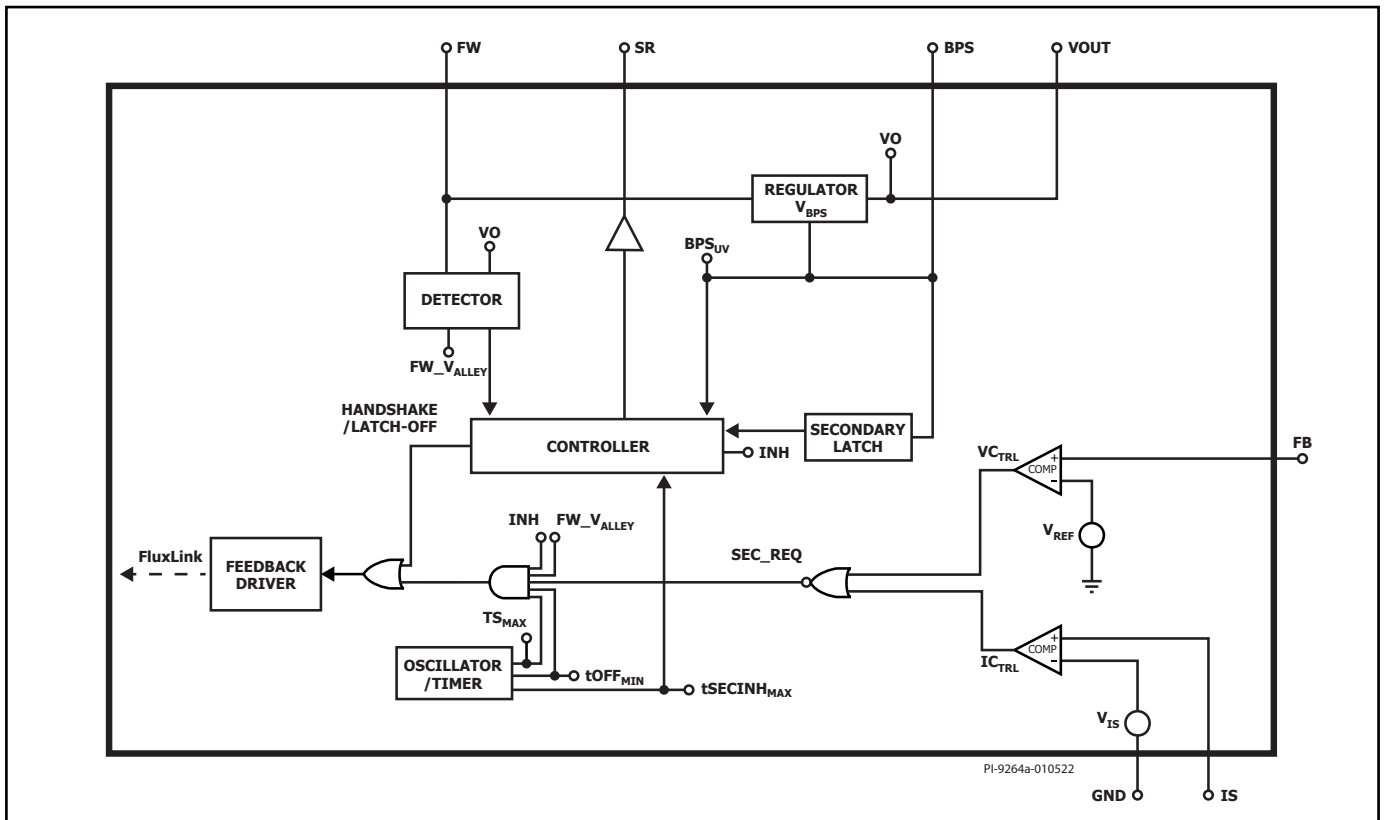

Figure 4. Secondary Controller Block Diagram.

## Pin Functional Description

### ISENSE (IS) Pin (Pin 1)

Connection to the power supply return output terminals. An external current sense resistor should be connected between this and the GND pin. If current regulation is not required, this pin should be tied to the GND pin.

### SECONDARY GROUND (GND) (Pin 2)

GND for the secondary IC. Note this is not the power supply output GND due to the presence of the sense resistor between this and the ISENSE pin.

### FEEDBACK (FB) Pin (Pin 3)

Connection to an external resistor divider to set the power supply output voltage.

### SECONDARY BYPASS (BPS) Pin (Pin 4)

Connection point for an external bypass capacitor for the secondary IC supply.

### SYNCHRONOUS RECTIFIER DRIVE (SR) Pin (Pin 5)

Gate driver for external SR FET. If no SR FET is used connect this pin to GND.

### OUTPUT VOLTAGE (VOUT) Pin (Pin 6)

Connected directly to the output voltage, to provide current for the controller on the secondary-side and provide secondary protection.

### FORWARD (FWD) Pin (Pin 7)

The connection point to the switching node of the transformer output winding providing information on primary switch timing. Provides power for the secondary-side controller when  $V_{OUT}$  is below a threshold value.

### NC Pin (Pin 8-12)

Leave open. Should not be connected to any other pins.

### UNDER/OVER INPUT VOLTAGE (V) Pin (Pin 13)

A high-voltage pin connected to the AC or DC side of the input bridge for detecting undervoltage and overvoltage conditions at the power supply input. This pin should be tied to GND to disable UV/OV protection.

### PRIMARY BYPASS (BPP) Pin (Pin 14)

The connection point for an external bypass capacitor for the primary-side supply. This is also the ILIM selection pin for choosing standard ILIM or ILIM+1.

### HSD Pin (Pin 15)

HSD pin is tied to ground.

### SOURCE (S) Pin (Pin 16-19)

These pins are the power switch source connection. It is also ground reference for primary BYPASS pin.

### DRAIN (D) Pin (Pin 24)

Power switch drain connection.

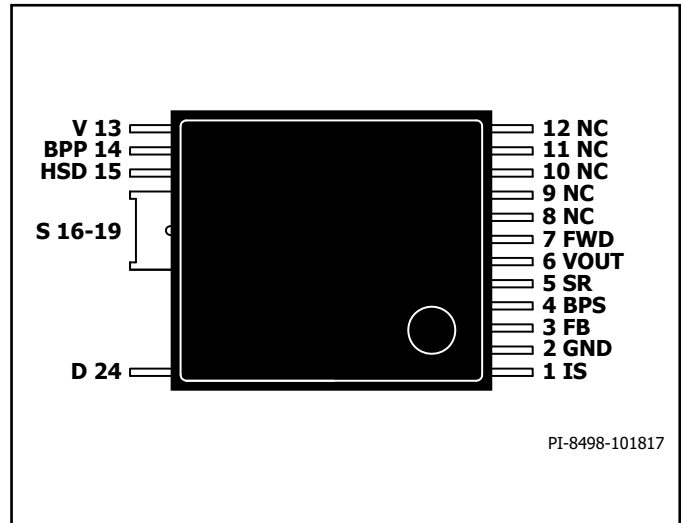

Figure 5. Pin Configuration.

## InnoSwitch4-QR Functional Description

The InnoSwitch4-QR IC combines a high-voltage power switch, along with both primary-side and secondary-side controllers in one device.

The architecture incorporates a proprietary inductive coupling feedback mechanism (FluxLink) using the package lead frame and bond wires to provide a safe, reliable, and cost-effective means to transmit switching requests from the secondary controller to the primary controller.

The primary controller on InnoSwitch4-QR is a Quasi-Resonant (QR) flyback controller that has the ability to operate in continuous conduction mode (CCM). The controller uses both variable frequency and variable current limit control scheme. The primary controller consists of a frequency jitter oscillator, a receiver circuit magnetically coupled to the secondary controller, a current limit controller, a 5 V regulator on the PRIMARY BYPASS pin, bypass overvoltage detection circuit, a lossless input line sensing circuit, current limit selection circuitry, over-temperature protection, leading edge blanking and power switch.

The InnoSwitch4-QR secondary controller consists of a transmitter circuit that is magnetically coupled to the primary receiver, a constant voltage (CV) and a constant current (CC) control circuit, a 4.5 V regulator on the SECONDARY BYPASS pin, synchronous rectifier FET driver, QR mode circuit (for optimal ZVS in DCM operation), oscillator and timing circuit, and numerous integrated protection features.

Figure 3 and Figure 4 show the functional block diagrams of the primary and secondary controller, highlighting the most important features.

## Primary Controller

InnoSwitch4-QRIC is a variable frequency controller allowing CCM/DCM operation for enhanced efficiency and extended output power capability.

### PRIMARY BYPASS Pin Regulator

The PRIMARY BYPASS pin has an internal regulator that charges the PRIMARY BYPASS pin capacitor to  $V_{BPP}$  by drawing current from the DRAIN pin whenever the power switch is off. The PRIMARY BYPASS pin is the internal supply voltage node. When the power switch is on, the device operates from the energy stored in the PRIMARY BYPASS pin capacitor.

In addition, a shunt regulator clamps the PRIMARY BYPASS pin voltage to  $V_{SHUNT}$  when current is provided to the PRIMARY BYPASS pin through an external resistor. This allows the InnoSwitch4-QR IC to be powered externally through a bias winding, decreasing the no-load consumption to less than 30 mW in a 5 V output design.

### Primary Bypass ILIM Programming

InnoSwitch4-QR ICs allows the user to adjust current limit (ILIM) settings through the selection of the PRIMARY BYPASS pin capacitor value. A ceramic capacitor can be used.

There are 2 selectable capacitor sizes – 0.47  $\mu$ F and 4.7  $\mu$ F for setting standard and increased ILIM settings respectively.

### Primary Bypass Undervoltage Threshold

The PRIMARY BYPASS pin undervoltage circuitry disables the power switch when the PRIMARY BYPASS pin voltage drops below  $\sim 4.5$  V ( $V_{BPP} - V_{BP(H)}$ ) in steady-state operation. Once the PRIMARY BYPASS pin voltage falls below this threshold, it must rise to  $V_{SHUNT}$  to re-enable turn-on of the power switch.

### Primary BYPASS Pin Overvoltage Function

The PRIMARY BYPASS pin has an optional latching OV protection feature. A Zener diode in parallel with the resistor in series with the PRIMARY BYPASS pin capacitor is typically used to detect an overvoltage on the primary bias winding and activate the protection mechanism. In the event that the current into the PRIMARY BYPASS pin exceeds  $I_{SD}$ , the device will latch-off or disable the power switch switching for a time  $t_{AR(OFF)}$  after which time the controller will restart and attempt to return to regulation.

VOU OV protection is also included as an integrated feature on the secondary controller (see Output Voltage Protection).

### Over-Temperature Protection

The thermal shutdown circuitry senses the primary switch die temperature. The threshold is set to  $T_{SD}$  with either a hysteretic or latch-off response.

**Hysteretic response:** If the die temperature rises above the threshold, the power switch is disabled and remains disabled until the die temperature falls by  $T_{SD(H)}$  at which point switching is re-enabled. A large amount of hysteresis is provided to prevent over-heating of the PCB due to a continuous fault condition.

**Latch-off response:** If the die temperature rises above the threshold the power switch is disabled. The latching condition is reset by bringing the PRIMARY BYPASS pin below  $V_{BPP(RESET)}$  or by going below the UNDER/OVER INPUT VOLTAGE pin UV ( $I_{UV}$ ) threshold.

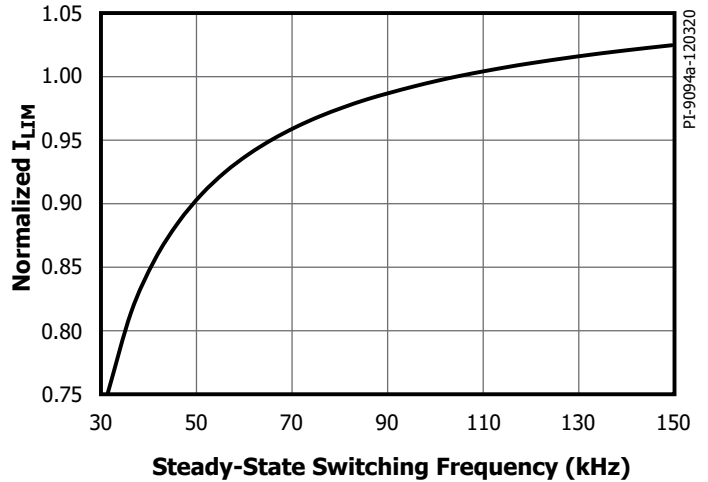

Figure 6. Normalized Primary Current vs. Frequency.

### Current Limit Operation

The primary-side controller has a current limit threshold ramp that is inversely proportional to the time from the end of the previous primary switching cycle (i.e. from the time the primary switch turns off at the end of a switching cycle).

This characteristic produces a primary current limit that increases as the switching frequency (load) increases (Figure 6).

This algorithm enables the most efficient use of the primary switch with the benefit that this algorithm responds to digital feedback information immediately when a feedback switching cycle request is received.

At full load, switching cycles have a maximum current approaching 100%  $I_{LIM}$ . This gradually reduces to 30% of the full current limit as load decreases. Once 30% current limit is reached, there is no further reduction in current limit (since this is low enough to avoid audible noise). The time between switching cycles will continue to increase as load reduces.

### Jitter

The normalized current limit is modulated between 100% and 95% at a modulation frequency of  $f_M$  this results in a frequency jitter of  $\sim 7$  kHz with average frequency of  $\sim 100$  kHz.

### Auto-Restart

In the event a fault condition occurs (such as an output overload, output short-circuit, or external component/pin fault), the InnoSwitch4-QR IC enters auto-restart (AR) or latches off. The latching condition is reset by bringing the PRIMARY BYPASS pin below  $\sim 3$  V or by going below the UNDER/OVER INPUT VOLTAGE pin UV ( $I_{UV}$ ) threshold.

In auto-restart, switching of the power switch is disabled for  $t_{AR(OFF)}$ . There are 2 ways to enter auto-restart:

1. Continuous secondary requests at above the overload detection frequency  $f_{OVL}$  for longer than 82 ms ( $t_{AR}$ ).
2. No requests for switching cycles from the secondary for  $> t_{AR(SK)}$ .

The second is included to ensure that if communication is lost, the primary tries to restart. Although this should never be the case in normal operation, it can be useful when system ESD events (for example) causes a loss of communication due to noise disturbing the secondary controller. The issue is resolved when the primary restarts after an auto-restart off-time.

The auto-restart is reset as soon as an AC reset occurs.

## SOA Protection

In the event that there are two consecutive cycles where the  $I_{LIM}$  is reached within  $\sim 500$  ns (the blanking time + current limit delay time), the controller will skip 2.5 cycles or  $\sim 25$   $\mu$ s. This provides sufficient time for the transformer to reset with large capacitive loads without extending the start-up time.

## Input Line Voltage Monitoring

The UNDER/OVER INPUT VOLTAGE pin is used for input undervoltage and overvoltage sensing and protection.

A sense resistor is tied between the high-voltage DC bulk capacitor after the bridge (or to the AC side of the bridge rectifier for fast AC reset) and the UNDER/OVER INPUT VOLTAGE pin to enable this functionality. This function can be disabled by shorting the UNDER/OVER INPUT VOLTAGE pin to primary GND.

At power-up, after the primary bypass capacitor is charged and the ILIM state is latched, and prior to switching, the state of the UNDER/OVER INPUT VOLTAGE pin is checked to confirm that it is above the brown-in and below the overvoltage shutdown thresholds.

In normal operation, if the UNDER/OVER INPUT VOLTAGE pin current falls below the brown-out threshold and remains below brown-out for longer than  $t_{UV}$ , the controller enters auto-restart. Switching will only resume once the UNDER/OVER INPUT VOLTAGE pin current is above the brown-in threshold.

In the event that the UNDER/OVER INPUT VOLTAGE pin current is above the overvoltage threshold, the controller will also enter auto-restart. Again, switching will only resume once the UNDER/OVER INPUT VOLTAGE pin current has returned to within its normal operating range.

The input line UV/OV function makes use of a internal high-voltage MOSFET on the UNDER/OVER INPUT VOLTAGE pin to reduce power consumption. If the cycle off-time  $t_{OFF}$  is greater than 50  $\mu$ s, the internal high-voltage MOSFET will disconnect the external sense resistor from the internal IC to eliminate current drawn through the sense resistor. The line sensing function will activate again at the beginning of the next switching cycle.

## Primary-Secondary Handshake

At start-up, the primary-side initially switches without any feedback information (this is very similar to the operation of a standard TOPSwitch™, TinySwitch™ or LinkSwitch™ controllers).

If no feedback signals are received during the auto-restart on-time ( $t_{AR}$ ), the primary goes into auto-restart mode. Under normal conditions, the secondary controller will power-up via the FORWARD pin or from the OUTPUT VOLTAGE pin and take over control. From this point onwards the secondary controls switching.

If the primary controller stops switching or does not respond to cycle requests from the secondary during normal operation (when the secondary has control), the handshake protocol is initiated to ensure that the secondary is ready to assume control once the primary begins to switch again. An additional handshake is also triggered if the secondary detects that the primary is providing more cycles than were requested.

The most likely event that could require an additional handshake is when the primary stops switching as the result of a momentary line brown-out event. When the primary resumes operation, it will default to a start-up condition and attempt to detect handshake pulses from the secondary.

If secondary does not detect that the primary responds to switching requests for 8 consecutive cycles, or if the secondary detects that the primary is switching without cycle requests for 4 or more consecutive cycles, the secondary controller will initiate a second handshake sequence. This provides additional protection against cross-conduction of the SR FET while the primary is switching. This protection mode also prevents an output overvoltage condition in the event that the primary is reset while the secondary is still in control.

## Wait and Listen

When the primary resumes switching after initial power-up recovery from an input line voltage fault (UV or OV) or an auto-restart event, it will assume control and require a successful handshake to relinquish control to the secondary controller.

As an additional safety measure the primary will pause for an auto-restart on-time period,  $t_{AR}$  ( $\sim 82$  ms), before switching. During this "wait" time, the primary will "listen" for secondary requests. If it sees two consecutive secondary requests, separated by  $\sim 30$   $\mu$ s, the primary will infer secondary control and begin switching in slave mode. If no pulses occurs during the  $t_{AR}$  "wait" period, the primary will begin switching under primary control until handshake pulses are received.

## Secondary Controller

As shown in the block diagram in Figure 4, the IC is powered by a 4.5 V ( $V_{BPS}$ ) regulator which is supplied by either VOUT or FWD. The SECONDARY BYPASS pin is connected to an external decoupling capacitor and fed internally from the regulator block.

For device operation below an output voltage of 5 V, the regulator has limited charging capability from the FWD pin and this can result in triggering  $VBPS_{(UVLO)(TH)}$ . An external bias supply should be considered to maintain BPS regulation.

The FORWARD pin also connects to the negative edge detection block used for both handshaking and timing to turn on the SR FET connected to the SYNCHRONOUS RECTIFIER DRIVE pin. The FORWARD pin voltage is used to determine when to turn off the SR FET in discontinuous mode operation. This is when the voltage across the  $R_{DS(ON)}$  of the SR FET drops below zero volts.

In continuous conduction mode (CCM) the SR FET is turned off when the feedback pulse is sent to the primary to demand the next switching cycle, providing excellent synchronous operation, free of any overlap for the FET turn-off.

The mid-point of an external resistor divider network between the OUTPUT VOLTAGE and SECONDARY GROUND pins is tied to the FEEDBACK pin to regulate the output voltage. The internal voltage comparator reference voltage is  $V_{FB}$  (1.265 V).

The external current sense resistor connected between ISENSE and SECONDARY GROUND pins is used to regulate the output current in constant current regulation mode.

### Minimum Off-Time

The secondary controller initiates a cycle request using the FluxLink connection to the primary. The maximum frequency of secondary-cycle requests is limited by a minimum cycle off-time of  $t_{OFF(MIN)}$ . This is in order to ensure that there is sufficient reset time after primary conduction to deliver energy to the load.

### Maximum Switching Frequency

The maximum switch-request frequency of the secondary controller is  $f_{SREQ}$ .

### Frequency Soft-Start

At start-up the primary controller is limited to a maximum switching frequency of  $f_{SW}$  and 75% of the maximum programmed current limit at the switch-request frequency of 100 kHz.

The secondary controller temporarily inhibits the FEEDBACK short protection threshold ( $V_{FB(OFF)}$ ) until the end of the soft-start timer  $\sim 10$  ms. After hand-shake is completed the secondary controller linearly ramps up the switching frequency from  $f_{SW}$  to  $f_{SREQ}$  over the 10 ms time period.

In the event of a short-circuit or overload at start-up, the device will move directly into CC (constant-current) mode. The device will go into auto-restart (AR), if the output voltage does not rise above the  $V_{FB(AR)}$  threshold before the expiration of the soft-start timer after handshake has occurred.

The secondary controller enables the FEEDBACK pin-short protection mode ( $V_{FB(OFF)}$ ) at the end of the soft-start time period. If the output short maintains the FEEDBACK pin below the short-circuit threshold, the secondary will stop requesting pulses triggering an auto-restart cycle.

If the output voltage reaches regulation within the soft-start time period, the frequency ramp is immediately aborted and the secondary controller is permitted to go full frequency. This will allow the controller to maintain regulation in the event of a sudden transient loading soon after regulation is achieved. The frequency ramp will only be aborted if quasi-resonant-detection programming has already occurred.

### Maximum Secondary Inhibit Period

Secondary requests to initiate primary switching are inhibited to maintain operation below maximum frequency and ensure minimum off-time. Besides these constraints, secondary-cycle requests are also inhibited during the "ON" time cycle of the primary switch (time between the cycle request and detection of FORWARD pin falling edge). The maximum time-out in the event that a FORWARD pin falling edge is not detected after a cycle requested is  $\sim 30 \mu s$ .

### Output Voltage Protection

In the event that the sensed voltage on the FEEDBACK pin is 2% higher than the regulation threshold, a bleed current of  $\sim 2.5$  mA (3 mA max) is applied on the OUTPUT VOLTAGE pin (weak bleed). This bleed current increases to  $\sim 200$  mA (strong bleed) in the event that the FEEDBACK pin voltage is raised beyond  $\sim 10\%$  of the internal FEEDBACK pin reference voltage. The current sink on the OUTPUT VOLTAGE pin is intended to discharge the output voltage after momentary overshoot events. The secondary does not relinquish control to the primary during this mode of operation.

If the voltage on the FEEDBACK pin is sensed to be 20% higher than the regulation threshold, a command is sent to the primary to either latch-off or begin an auto-restart sequence (see Secondary Fault Response in Feature Code Addendum). This integrated  $V_{OUT}$  OVP can be used in conjunction or independently from the primary sensed OVP.

### FEEDBACK Pin Short Detection

If the sensed FEEDBACK pin voltage is below  $V_{FB(OFF)}$  at start-up, the secondary controller will complete the handshake to take control of the primary complete  $t_{SS(RAMP)}$  and will stop requesting cycles to initiate auto-restart (no cycle requests made to primary for longer than  $t_{AR(SK)}$  second triggers auto-restart).

During normal operation, the secondary will stop requesting pulses from the primary to initiate an auto-restart cycle when the FEEDBACK pin voltage falls below the  $V_{FB(OFF)}$  threshold. The deglitch filter on the protection mode is less than  $\sim 10 \mu s$ . The secondary will relinquish control after detecting that the FEEDBACK pin is shorted to ground.

### Auto-Restart Thresholds

The FEEDBACK pin includes a comparator to detect when the output voltage falls below  $V_{FB(AR)}$  of  $V_{FB}$  for a duration exceeding  $t_{FB(AR)}$ . The secondary controller will relinquish control when this fault condition is sensed. This threshold is meant to limit the range of constant current (CC) operation.



## SECONDARY BYPASS Pin Overvoltage Protection

The InnoSwitch4-QR secondary controller features SECONDARY BYPASS pin OV feature similar to PRIMARY BYPASS pin OV feature. When the secondary is in control: in the event the SECONDARY BYPASS pin current exceeds  $I_{BPS(SD)}$  ( $\sim 7$  mA) the secondary will send a command to the primary to initiate an auto-restart off-time ( $t_{AR(OFF)}$ ) or latch-off event (see Secondary Fault Response in Feature Code Addendum).

## Output Constant Current

The InnoSwitch4-QR IC regulates the output current through an external current sense resistor between the ISENSE and SECONDARY GROUND pins where the voltage generated across the resistor is compared to an internal reference of  $I_{SV(TH)}$  ( $\sim 35$  mV). If constant current regulation is not required, the ISENSE pin must be tied to SECONDARY GROUND pin.

## SR Disable Protection

In each cycle SR is only engaged if a set cycle was requested by the secondary controller and the negative edge is detected on the FORWARD pin. In the event that the voltage on the ISENSE pin exceeds approximately 3 times the CC threshold, the SR FET drive is disabled until the surge current has diminished to nominal levels.

## SR Static Pull-Down

To ensure that the SR gate is held low when the secondary is not in control, the SYNCHRONOUS RECTIFIER DRIVE pin has internal pull down circuit "ON" device to pull the pin low and reduce any voltage on the SR gate due to capacitive coupling from the FORWARD pin.

## Open SR Protection

In order to protect against an open SYNCHRONOUS RECTIFIER DRIVE pin system fault the secondary controller has a protection mode to ensure the SYNCHRONOUS RECTIFIER DRIVE pin is connected to an external FET. If the external capacitance on the SYNCHRONOUS RECTIFIER DRIVE pin is below 200 pF, the device will assume the SYNCHRONOUS RECTIFIER DRIVE pin is "open" and

there is no FET to drive. If the pin capacitance detected is above 200 pF, the controller will assume an SR FET is connected.

In the event the SYNCHRONOUS RECTIFIER DRIVE pin is detected to be open, the secondary controller will stop requesting pulses from the primary to initiate auto-restart.

If the SYNCHRONOUS RECTIFIER DRIVE pin is tied to ground at start-up, the SR drive function is disabled and the open SYNCHRONOUS RECTIFIER DRIVE pin protection mode is also disabled.

## Intelligent Quasi-Resonant Mode Switching

In order to improve conversion efficiency and reduce switching losses, the InnoSwitch4-QR features a means to force switching when the voltage across the primary switch is near its minimum voltage when the converter operates in discontinuous conduction mode (DCM). This mode of operation is automatically engaged in DCM and disabled once the converter moves to continuous conduction mode (CCM).

Rather than detecting the magnetizing ring valley on the primary-side, the peak voltage of the FORWARD pin voltage as it rises above the output voltage level is used to gate secondary requests to initiate the switch "ON" cycle in the primary controller.

The secondary controller detects when the controller enters in discontinuous-mode and opens secondary cycle request windows corresponding to minimum switching voltage across the primary power switch.

Quasi-Resonant (QR) mode is enabled for 20 msec after DCM is detected. QR switching is disabled after 20 msec, at which point switching may occur at any time a secondary request is initiated. The secondary controller includes blanking of  $\sim 1$  msec to prevent false detection of primary "ON" cycle when the FORWARD pin rings below ground.

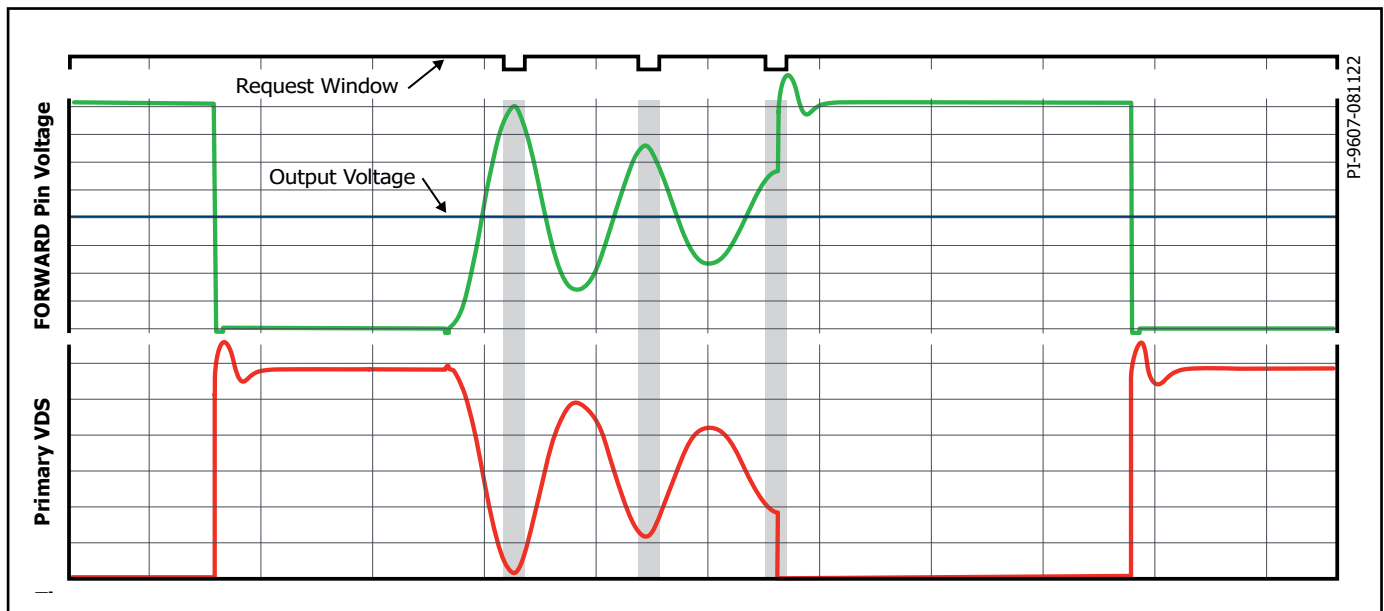

Figure 7. Intelligent Zero Voltage Switching.

## Peak Power Delivery

Output overload response depends on whether the IS pin is shorted to ground or the design includes a current sense resistor to set the overload threshold.

If there is an external current sense resistor on the IS pin, the InnoSwitch has options to set the overload response in two different ways.

If the device is configured to have the FEEDBACK pin auto-restart enabled, once the load current reaches the current limit threshold set by the IS pin resistor, the output voltage will fold back and auto-restart will occur once the output voltage falls below the AR threshold for a time period exceeding the AR timer.

If the device is configured for overload response, once the load current exceeds the current sense threshold the output voltage does not fold back. The auto-restart timer will begin and auto-restart occurs if the load current remains higher than the current sense threshold for a time period exceeding the AR timer. After the AR timer expires, secondary stops sending switching requests to primary for ~45 ms before triggering AR. If the load current falls below the current sense threshold during this time, the secondary will start sending requests normally without triggering auto-restart.

The two cases where a current sense resistor is included in the design are shown in the Figure 8 above.

If the IS pin is shorted to the GND pin, the overload response heavily depends on the operating conditions. If the device is configured to have feedback auto-restart enabled ( $V_{FB(AR)}$ ), auto-restart will occur if the output voltage droops below the auto-restart threshold for longer than the auto-restart timer ( $t_{FB(AR)}$ ). Otherwise, the auto-restart occurs if the primary switches above the overload frequency limit ( $f_{OVL}$ ) for longer than the auto-restart on-time ( $t_{AR}$ ).

## DCM Only Mode

For INN477xC with PFC input or high-line input design, DCM is always preferred due to lower SR voltage spike when primary turn-on. InnoSwitch4-QR IC has an option to only allow DCM switching cycles. The earliest switching window will be enabled at the first valley of resonance rings from FORWARD pin voltage. To ensure power delivery across design corner,  $K_p > 1.2$  is recommended to enable this feature.

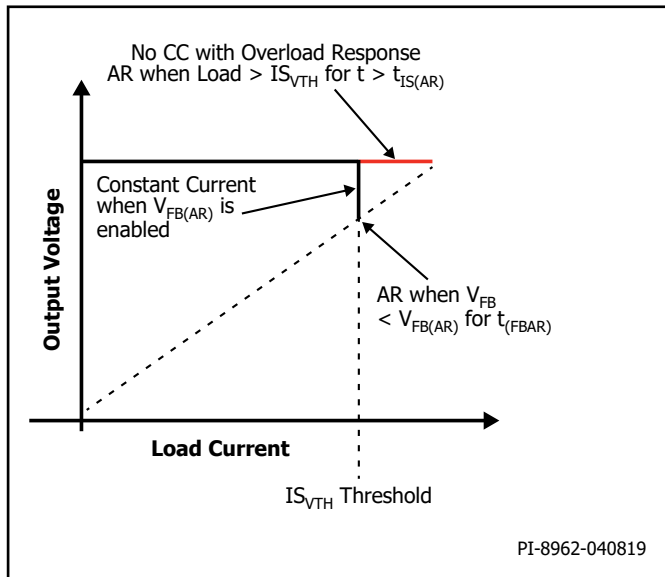

Figure 8. Current Sense Resistor in a Design.



## Application Example

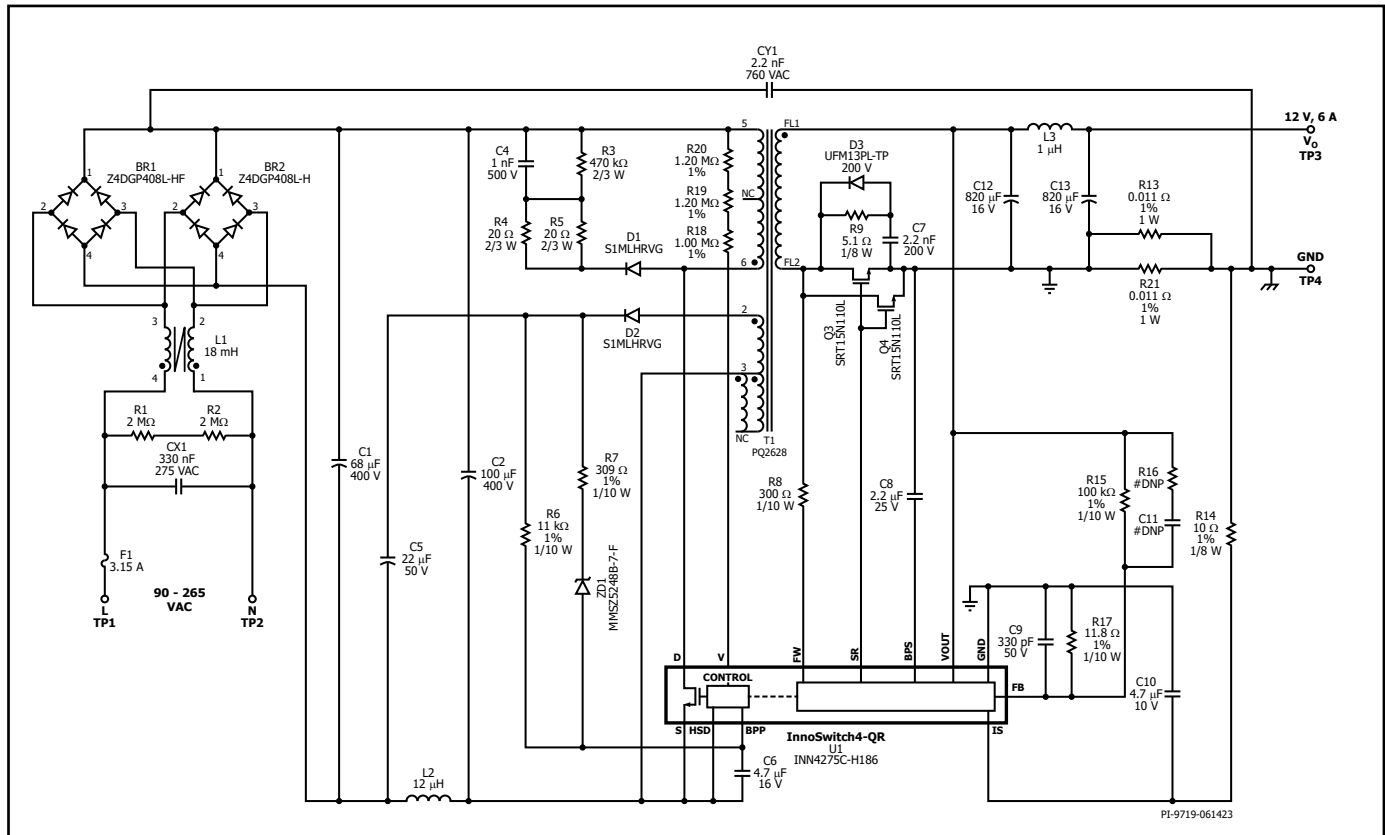

Figure 9. Schematic of 72 W Network Power Supply using InnoSwitch4-QR IC.

The circuit shown in Figure 9 is a 12 V, 6 A 72 W power supply using the INN4275-Hxxx IC. This network power supply is DOE level 6 and EC CoC v5 compliant.

Input fuse F1 isolates the circuit and provides protection from component failure. Common mode choke L1 along with Y capacitor CY1 provides common mode noise filtering while inductor L2 forms a pi filter with capacitors C1 and C2 for differential mode EMI filtering along with CX1. Resistors R1 and R2 will dissipate stored energy in CX1 capacitor during turn off power supply for safety. Bridge rectifiers BR1 and BR2 rectify AC line voltage and provide full wave rectified DC.

One end of the transformer primary is connected to the rectified DC bus; the other is connected to the drain terminal of the InnoSwitch4-QR IC. Resistors R18, R19 and R20 provide input voltage sense protection for undervoltage and overvoltage conditions.

The R2CD primary clamp circuit formed by D1, R3, R4, R5, and C4 limits the peak drain voltage of U1 at the instant of turn-off of the switch inside U1.

InnoSwitch4-QR U1 is self-starting, using an internal high-voltage current source to charge the BPP pin capacitor C6 when AC is first applied. During normal operation, the primary-side block is powered from an auxiliary winding on the transformer T1. Output of the auxiliary (or bias) winding is rectified using diode D2 and filtered using capacitor C5. R6 resistance determines the amount of current fed into the BPP pin of the InnoSwitch4-QR IC. By injecting sufficient current into BPP, the internal current source of U1 is not required to charge C6, and power consumption is minimized during no-load condition and normal operation.

Zener diode ZD1 offers primary sensed output overvoltage. In a flyback converter, output of the auxiliary winding tracks the output voltage of the converter. In case of overvoltage at the output of the converter, the auxiliary winding voltage increases and causes breakdown of ZD1 which then causes excess current to flow into the BPP pin of InnoSwitch4-QR IC. If the current flowing into the BPP pin increases above the ISD threshold, the InnoSwitch4-QR controller will latch off and prevent any further increase in output voltage. Resistor R7 limits the current injected to BPP pin when the output overvoltage protection is triggered.

Output regulation is achieved using modulation control where the frequency and ILIM of switching cycles are adjusted based on output load. At high load, most switching cycles are enabled for a high value of ILIM in the selected ILIM range while at light load or no-load, most cycles are disabled and the ones enabled have a low value of ILIM in the selected ILIM range. Once a cycle is enabled, the switch remains ON until the primary current ramps to the device current limit for the specific operating state.

The secondary-side of the InnoSwitch4-QR IC provides output voltage and current sensing and a gate drive to a FET for synchronous rectification. The voltage across the transformer secondary winding is rectified by the secondary-side synchronous rectifier FETs (SR FET) Q3 and Q4 and filtered by capacitors C12, L3, and C13. High frequency ringing during switching transients that would otherwise create radiated EMI is reduced via an RCD snubber, R9, C7, and D3. Diode D3 minimizes the dissipation in resistor R9.

The gate of Q3 and Q4 is turned on by secondary-side controller inside IC U1, based on the secondary winding voltage sensed via resistor R8 and fed into the FWD pin of the IC.

In continuous conduction mode of operation, the SR FET is turned off just prior to the secondary-side commanding through FluxLink a new switching cycle from the primary. In discontinuous mode of operation, the SR FET is turned off when the magnitude of the voltage drop across the SR FET falls below a threshold of approximately  $V_{SR(TH)}$ .

Secondary-side control of the primary-side power switch avoids any possibility of cross conduction of the two switches and provides extremely reliable synchronous rectifier operation.

Resistor R8 limits the current flowing to the BPS pin of U1. Capacitor C8 connected to the BPS pin of InnoSwitch4-QR IC provides decoupling for the internal circuitry.

The output current is sensed by monitoring the voltage drop across resistor R13 and R21. The current measurement is filtered with resistor R14 and capacitor C10, and then monitored across the IS and SECONDARY GROUND pins. An internal current sense threshold of up to approximately 32 mV is used to reduce the losses. Once the output current threshold is exceeded, the InnoSwitch4-QR IC responds depending on its configuration to either maintain a fixed output current by using variable frequency and variable primary switch peak current control schemes or to shut down the power supply. The output voltage regulation is achieved through sensing the output voltage via divider resistors R15 and R17. The voltage across R17 is fed into the FB pin with an internal reference voltage threshold of 1.265 V. The output voltage is regulated so as to achieve a voltage of 1.265 V on the FB pin. Capacitor C9 provides noise filtering of a signal at the FB pin, Resistor R16 and C11 can be used as feed-forward circuits to reduce the output ripple if necessary.

Layout Example

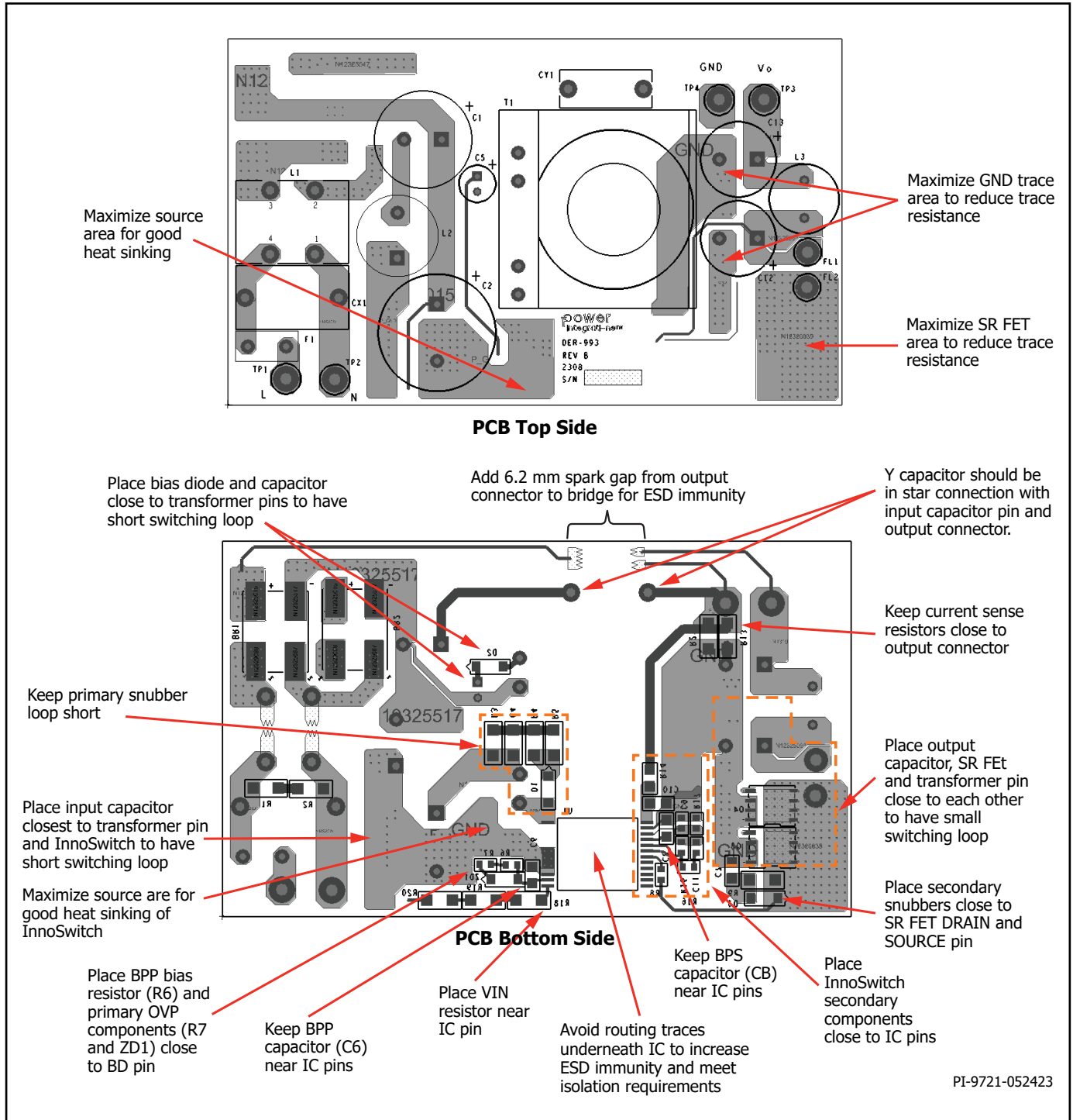

Figure 10. PCB Layout Example.

## Key Application Considerations

### Output Power Table

The data sheet output power table (Table 1) represents the maximum practical continuous output power level that can be obtained under the following conditions:

1. The minimum DC input voltage is 90 V or higher for 85 VAC input, 220 V or higher for 230 VAC input or 115 VAC with a voltage-doubler. Input capacitor voltage should be sized to meet these criteria for AC input designs.
2. Efficiency assumptions depend on power level. Smallest device power level assumes efficiency >87% increasing to >92% for the largest device.
3. Transformer primary inductance tolerance of  $\pm 7\%$ .
4. Reflected output voltage (VOR) is set to maintain  $K_p = 0.7$  at minimum input voltage for universal line and  $K_p = 1.2$  for high input line designs (for thermally constrained environment efficiency should be >92% with larger devices).
5. Maximum conduction losses for adapters is limited to 0.6 W, 0.8 W for open frame designs.
6. Increased current limit is selected for peak and open frame power columns and standard current limit for adapter columns.
7. The part is board mounted with SOURCE pins soldered to a sufficient area of copper and/or a heat sink to keep the SOURCE pin temperature at or below 110 °C.
8. Ambient temperature of 50 °C for open frame designs and 40 °C for sealed adapters.
9. Below a value of 1,  $K_p$  is the ratio of ripple to peak primary current. To prevent reduced power delivery, due to premature termination of switching cycles, a transient  $K_p$  limit of  $\geq 0.25$  is recommended. This prevents the initial current limit ( $I_{INT}$ ) from being exceeded at switch turn-on.

### Primary-Side Overvoltage Protection (Latch-Off/Auto-Restart Mode)

Primary-side output overvoltage protection provided by the InnoSwitch4-QR IC uses an internal protection depending on H code that is triggered by a threshold current of  $I_{SD}$  into the PRIMARY BYPASS pin. In addition to an internal filter, the PRIMARY BYPASS pin capacitor forms an external filter helping noise immunity. For the bypass capacitor to be effective as a high frequency filter, the capacitor should be located as close as possible to the SOURCE and PRIMARY BYPASS pins of the device.

The primary sensed OVP function can be realized by connecting a series combination of a Zener diode, a resistor and a blocking diode from the rectified and filtered bias winding voltage supply to the PRIMARY BYPASS pin. The rectified and filtered bias winding output voltage may be higher than expected (up to 1.5X or 2X the desired value) due to poor coupling of the bias winding with the output winding and the resulting ringing on the bias winding voltage waveform. It is therefore recommended that the rectified bias winding voltage be measured. This measurement should be ideally done at the lowest input voltage and with highest load on the output. This measured voltage should be used to select the components required to achieve primary sensed OVP. It is recommended that a Zener diode with a clamping voltage approximately 6 V lower than the bias winding rectified voltage at which OVP is expected to be triggered be selected. A forward voltage drop of 1 V can be assumed for the blocking diode. A small signal standard recovery diode is recommended. The blocking diode prevents any reverse current discharging the bias capacitor during start-up. Finally, the value of the series resistor required can be calculated such that a current higher than  $I_{SD}$  will flow into the PRIMARY BYPASS pin during an output overvoltage.

### Reducing No-Load Consumption

The InnoSwitch4-QR IC can start in self-powered mode, drawing energy from the BYPASS pin capacitor charged through an internal current source. Use of a bias winding, however, is required to provide supply current to the PRIMARY BYPASS pin, once the InnoSwitch4-QR IC has started switching. An auxiliary (bias) winding provided on the transformer serves this purpose. A bias winding driver supply to the PRIMARY BYPASS pin enables design of power supplies with no-load power consumption less than 30 mW.

### Secondary-Side Overvoltage Protection (Auto-Restart Mode)

The secondary-side output overvoltage protection provided by the InnoSwitch4-QR IC uses an internal auto restart circuit that is triggered by an input current exceeding a threshold of  $I_{BPS(SD)}$  into the SECONDARY BYPASS pin. The direct output sensed OVP function can be realized by connecting a Zener diode from the output to the SECONDARY BYPASS pin. The Zener diode voltage needs to be the difference between  $1.25 \times V_{OUT}$  and 4.5 V – the SECONDARY BYPASS pin voltage. It is necessary to add a low value resistor in series with the OVP Zener diode to limit the maximum current into the SECONDARY BYPASS pin.

## Selection of Components

### Components for InnoSwitch4-QR Primary-Side Circuit

#### BPP Capacitor

A capacitor connected from the PRIMARY BYPASS pin of the InnoSwitch4-QR IC to GND provides decoupling for the primary-side controller and also selects current limit. A 0.47  $\mu\text{F}$  or 4.7  $\mu\text{F}$  capacitor may be used. Though electrolytic capacitors can be used, often surface mount multi-layer ceramic capacitors are preferred for use on double sided boards as they enable placement of capacitors close to the IC. Their small size also makes it ideal for compact power supplies. At least 10 V, 0805 or larger size rated X5R or X7R dielectric capacitors are recommended to ensure that minimum capacitance requirements are met. The ceramic capacitor type designations, such as X7R, X5R from different manufacturers or different product families do not have the same voltage coefficients. It is recommended that capacitor data sheets be reviewed to ensure that the selected capacitor will not have more than 20% drop in capacitance at 5 V. Do not use Y5U or Z5U / 0603 rated MLCC due to this type of SMD ceramic capacitor has very poor voltage and temperature coefficient characteristics.

#### Bias Winding and External Bias Circuit

The internal regulator connected from the DRAIN pin of the switch to the PRIMARY BYPASS pin of the InnoSwitch4-QR primary-side controller charges the capacitor connected to the PRIMARY BYPASS pin to achieve start-up. A bias winding should be provided on the transformer with a suitable rectifier and filter capacitor to create a bias supply that can be used to supply at least 4 mA of current to the PRIMARY BYPASS pin clamp BP1 and BP2 pins.

The turns ratio for the bias winding should be selected such that 7 V to 8 V minimum is developed across the bias winding at the lowest rated output voltage of the power supply at the lowest load condition. If the voltage is lower than this, no-load input power will increase.

In USB PD or rapid charge applications, the output voltage range is very wide. For example, a 45 W adapter would need to support 5 V, 9 V and 15 V and a 100 W adapter would have output voltages selectable from 5 V to 20 V. Such a wide output voltage variation results in a large change in bias winding output voltage as well. A linear regulator circuit is generally required to limit the current injected into the PRIMARY BYPASS pin of the InnoSwitch4-QR IC.

An aluminum capacitor of at least 22  $\mu\text{F}$  with a voltage rating 1.2 times greater than the highest voltage developed across the capacitor is recommended. Highest voltage is typically developed across this

capacitor when the supply is operated at the highest rated output voltage and load with the lowest input AC supply voltage.

### Line UV and OV Protection

Resistors connected from the UNDER/OVER INPUT VOLTAGE pin to the DC bus enable sensing of input voltage to provide line undervoltage and overvoltage protection. For a typical universal input application, a resistor value of 4 M $\Omega$  is recommended.

InnoSwitch4-QR IC features a primary sensed OV protection feature that can be used to latch-off the power supply. Once the power supply is latched off, it can be reset if the UNDER/OVER INPUT VOLTAGE pin current is reduced to zero. Once the power supply is latched off, even after the input supply is turned off, it can take considerable amount of time to reset the InnoSwitch4-QR controller as the energy stored in the DC bus will continue to provide current to the controller. A fast AC reset can be achieved using the modified circuit configuration shown in Figure 12. The voltage across capacitor C5 reduces rapidly after input supply is disconnected reducing current into the INPUT VOLTAGE MONITOR pin of the InnoSwitch4-QR IC and resetting the InnoSwitch4-QR controller.

### Primary Sensed OVP (Overvoltage Protection)

The voltage developed across the output of the bias winding tracks the power supply output voltage. Though not precise, a reasonably accurate detection of the amplitude of the output voltage can be achieved by the primary-side controller using the bias winding voltage. A Zener diode connected from the bias winding output to the PRIMARY BYPASS pin can reliably detect a secondary overvoltage fault and cause the primary-side controller to latch-off/auto-restart depending on feature code. It is recommended that the highest voltage at the output of the bias winding should be measured for normal steady-state conditions (at full load and lowest input voltage) and also under transient load conditions. A Zener diode rated for 1.25 times this measured voltage will typically ensure that OVP protection will only operate in case of a fault.

### SECONDARY BYPASS Pin – Decoupling Capacitor

A 2.2  $\mu$ F, 10 V / X7R or X5R / 0805 or larger size multi-layer ceramic capacitor should be used for decoupling the SECONDARY BYPASS pin of the InnoSwitch4-QR IC. Since the SECONDARY BYPASS pin voltage needs to be 4.5 V before the output voltage reaches the regulation voltage level, a significantly higher BPS capacitor value

could lead to output voltage overshoot during start-up. Values lower than 1.5  $\mu$ F may not offer enough capacitance, and cause unpredictable operation. The capacitor must be located adjacent to the IC pins. At least 10 V is recommended voltage rating to give enough margin from BPS voltage, and 0805 size is necessary to guarantee the actual value in operation since the capacitance of ceramic capacitors drops significantly with applied DC voltage especially with small package SMD such as 0603. 6.3 V / 0603 / X5U or Z5U type of MLCC is not recommended for this reason. The ceramic capacitor type designations, such as X7R, X5R from different manufacturers or different product families do not have the same voltage coefficients. It is recommended that capacitor data sheets be reviewed to ensure that the selected capacitor will not have more than 20% drop in capacitance at 4.5 V. Capacitors with X5R or X7R dielectrics should be used for best results.

When the output voltage of the power supply is 5 V or higher, the supply current for the secondary-side controller is provided by the OUTPUT VOLTAGE (VOUT) pin of the IC as the voltage at this pin is higher than the SECONDARY BYPASS pin voltage. During start-up and operating conditions where the output voltage of the power supply is below 5 V, the secondary-side controller is supplied by current from an internal current source connected to the FORWARD pin. If the output voltage of the power supply is below 5 V and the load at the output of the power supply is very light, the operating frequency can drop significantly and the current supplied to the secondary-side controller from the FORWARD pin may not be sufficient to maintain the SECONDARY BYPASS pin voltage at 4.5 V. For such applications, it is recommended that an additional active preload be used as shown in Figure 11. This load is turned on by the interface IC (or USB PD controller) when the output voltage of the power supply is below 5 V.

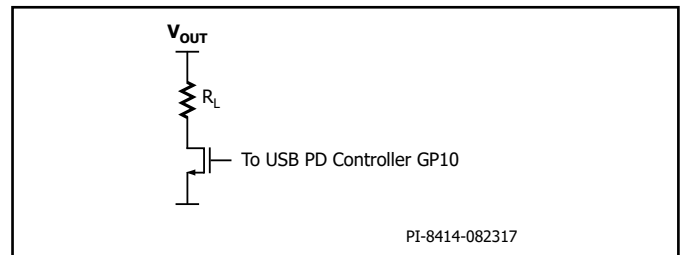

Figure 11. Active Pre-Load Circuit.

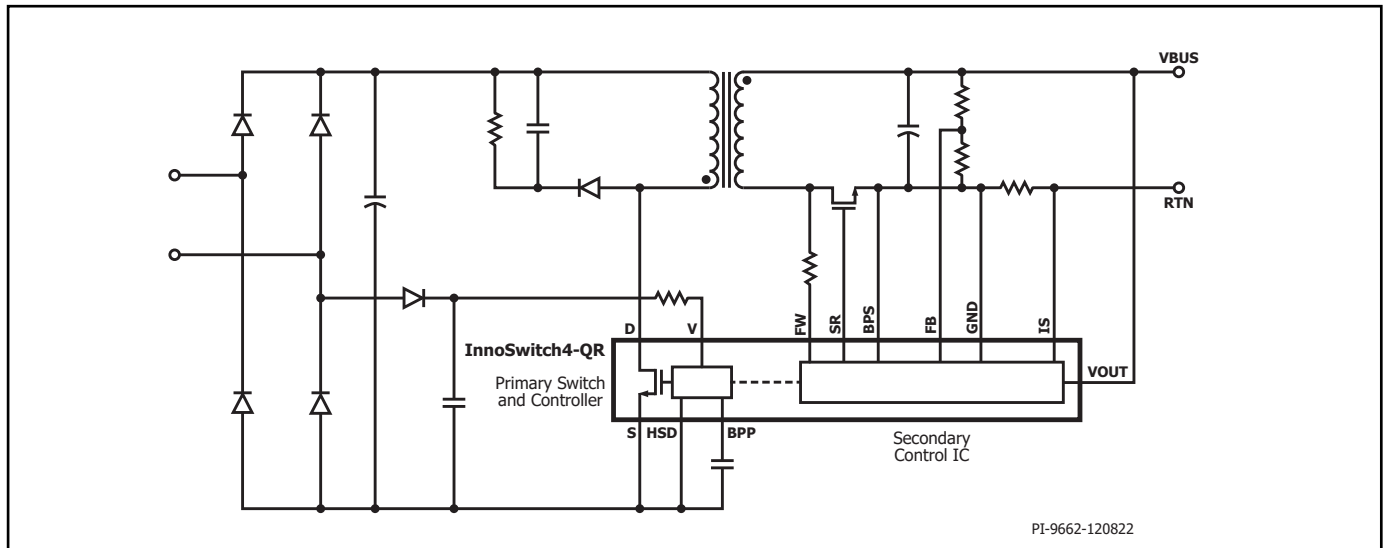

Figure 12. Fast AC Reset Configuration.

## FORWARD Pin Resistor

A 300  $\Omega$ , 5% resistor is recommended to ensure sufficient IC supply current. A higher or lower resistor value should not be used as it can affect device operation such as the timing of the synchronous rectifier drive. Figures 13, 14, 15 and 16 below show examples of unacceptable and acceptable FORWARD pin voltage waveforms.  $V_D$  is forward voltage drop across the SR.

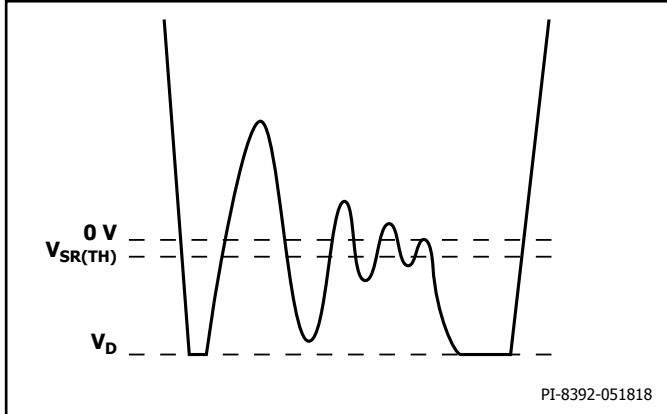

Figure 13. Unacceptable FORWARD Pin Waveform After Handshake with SR Switch Conduction During Flyback Cycle.

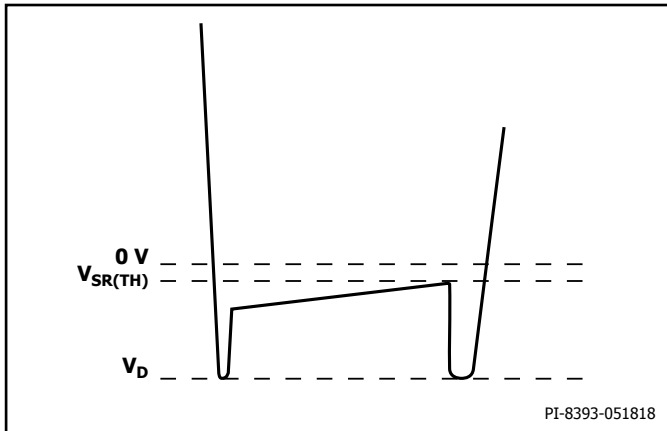

Figure 14. Acceptable FORWARD Pin Waveform After Handshake with SR Switch Conduction During Flyback Cycle.

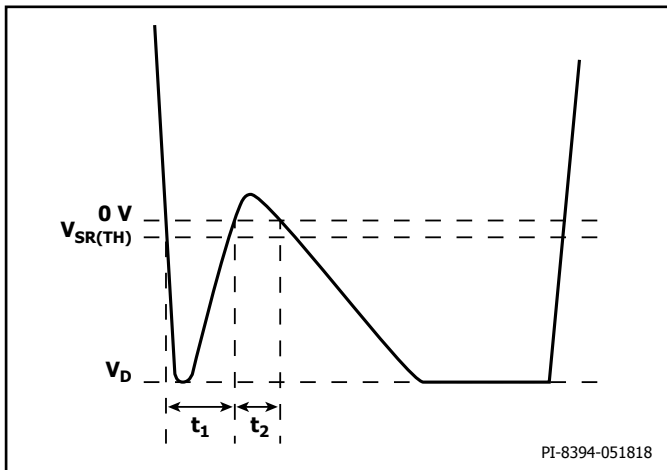

Figure 15. Unacceptable FORWARD Pin Waveform Before Handshake with Body Diode Conduction During Flyback Cycle.

Note:

If  $t_1 + t_2 = 1.5 \mu\text{s} \pm 50 \text{ ns}$ , the controller may fail the handshake and trigger a primary bias winding OVP latch-off/auto-restart.

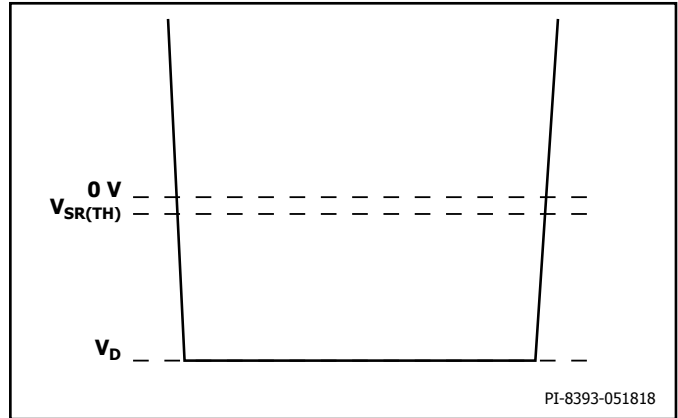

Figure 16. Acceptable FORWARD Pin Waveform Before Handshake with Body Diode Conduction During Flyback Cycle.

## SR FET Operation and Selection

Although a simple diode rectifier and filter works for the output, use of an SR FET enables the significant improvement in operating efficiency often necessary to meet the European CoC and the U.S. DoE energy efficiency requirements. The secondary-side controller turns on the SR FET once the flyback cycle begins. The SR FET gate should be tied directly to the SYNCHRONOUS RECTIFIER DRIVE pin of the InnoSwitch4-QR IC (no additional resistors should be connected in the gate circuit of the SR FET). The SR FET is turned off once the  $V_{DS}$  of the SR FET reaches 0 V.

A FET with 8 m $\Omega$   $R_{DS(ON)}$  is appropriate for 20 V, 3 A output and a FET with 6 m $\Omega$   $R_{DS(ON)}$  is suitable for designs rated with 20 V, 5 A. Parallel two SR FET's for higher output current designs. The SR FET driver uses the SECONDARY BYPASS pin for its supply rail, and this voltage is typically 4.5 V. A FET with a high threshold voltage is therefore not suitable; FETs with a threshold voltage of 1.5 V to 2.5 V are ideal although switches with a threshold voltage (absolute maximum) as high as 4 V may be used provided their data sheets specify  $R_{DS(ON)}$  across temperature for a gate voltage of 4.5 V.

A Schottky diode is recommended across the SR FET. In addition to this there is a slight delay between the commencement of the flyback cycle and the turn-on of the SR FET. During this time, the body diode of the SR FET conducts. If an external parallel Schottky diode is used, this current mostly flows through the Schottky diode. Once the InnoSwitch4-QR IC detects end of the flyback cycle, voltage across SR FET  $R_{DS(ON)}$  reaches 0 V, any remaining portion of the flyback cycle is completed with the current commutating to the body diode of the SR FET or the external parallel Schottky diode. Use of the Schottky diode parallel to the SR FET may provide higher efficiency. However, the gains are modest. An efficiency increase of 0.2% or higher is expected with the addition of Schottky diode for designing with an output current rating  $>2$  A.

The voltage rating of the Schottky diode and the SR FET should be at least 1.4 times the expected peak inverse voltage (PIV) based on the turns ratio used for the transformer. 60 V rated FETs and diodes are suitable for most 5 V designs that use a  $V_{OR} < 60$  V, and 100 V rated FETs and diodes are suitable for 12 V designs.



The interaction between the leakage reactance of the output windings and the SR FET capacitance ( $C_{OSS}$ ) leads to ringing on the voltage waveform at the instance of voltage reversal at the winding due to primary switch turn-on. This ringing can be suppressed using an RC snubber connected across the SR FET. A snubber resistor in the range of  $10\ \Omega$  to  $47\ \Omega$  may be used (higher resistance values lead to noticeable drop in efficiency). A capacitance value of  $220\ \text{pF}$  to  $2.2\ \text{nF}$  is adequate for most designs.

### Output Capacitor

Low ESR aluminum electrolytic capacitors are suitable for use with most high frequency flyback switching power supplies though the use of aluminum-polymer solid capacitors have gained considerable popularity due to their compact size, stable temperature characteristics, extremely low ESR and high RMS ripple current rating. These capacitors enable the design of ultra-compact chargers and adapters.

Typically,  $200\ \mu\text{F}$  to  $300\ \mu\text{F}$  of aluminum-polymer capacitance per ampere of output current is adequate. The other factor that influences choice of the capacitance is the output ripple. Ensure that capacitors with a voltage rating higher than the highest output voltage plus sufficient margin be used.

### Output Voltage Feedback Circuit

The output voltage FEEDBACK pin voltage is  $1.265\ \text{V}$  [ $V_{FB}$ ]. A voltage divider network should be connected at the output of the power supply to divide the output voltage such that the voltage at the FEEDBACK pin will be  $1.265\ \text{V}$  when the output is at its desired voltage. The lower feedback divider resistor should be tied to the SECONDARY GROUND pin. A  $300\ \text{pF}$  (or smaller) decoupling capacitor should be connected at the FEEDBACK pin to the SECONDARY GROUND pin of the InnoSwitch4-QR IC. This capacitor should be placed close to the InnoSwitch4-QR IC.

### Output Overload Protection

For output voltage below the  $V_{PK}$  threshold, the InnoSwitch4-QR IC will limit the output current once the voltage across the IS and GND pins exceeds the current limit or  $I_{SV(TH)}$  threshold. This provides current limit or constant current operation. The current limit is set by the programming resistor between the ISENSE and SECONDARY GROUND pins. For any output voltage above the  $V_{PK}$  threshold, InnoSwitch4-QR IC will provide a constant power characteristic. An increase in load current will result in a drop in output voltage such that the product of output voltage and current equals the maximum power set by the product of  $V_{PK}$  and set current limit.

### Interfacing with USB PD and Rapid Charge Controllers

A micro controller can be used to alter the feedback voltage divider in order to increase or decrease the output voltage. The interface IC can also use the signal from the InnoSwitch4-QR ISENSE pin to sense output current and provide current, power limiting or protection features.

### Recommendations for Circuit Board Layout

See Figure 10 for a recommended circuit board layout for an InnoSwitch4-QR based power supply.

### Single-Point Grounding

Use a single-point ground connection from the input filter capacitor to the area of copper connected to the SOURCE pins.

### Bypass Capacitors

The PRIMARY BYPASS and SECONDARY BYPASS pin capacitor must be located directly adjacent to the PRIMARY BYPASS-SOURCE and SECONDARY BYPASS-SECONDARY GROUND pins respectively and connections to these capacitors should be routed with short traces.

### Primary Loop Area

The area of the primary loop that connects the input filter capacitor, transformer primary and IC should be kept as small as possible.

### Thermal Considerations

The SOURCE pin is internally connected to the IC lead frame and provides the main path to remove heat from the device. Therefore the SOURCE pin should be connected to a copper area underneath the IC to act not only as a single point ground, but also as a heat sink. As this area is connected to the quiet source node, it can be maximized for good heat sinking without compromising EMI performance. Similarly for the output SR switch, maximize the PCB area connected to the pins on the package through which heat is dissipated from the SR switch.

Sufficient copper area should be provided on the board to keep the IC temperature safely below the absolute maximum limits. It is recommended that the copper area provided for the copper plane on which the SOURCE pin of the IC is soldered is sufficiently large to keep the IC temperature below  $110\ ^\circ\text{C}$  when operating the power supply at full rated load and at the lowest rated input AC supply voltage.

### Y Capacitor

The Y capacitor should be placed directly between the primary input filter capacitor positive terminal and the output positive or return terminal of the transformer secondary. This routes high amplitude common mode surge currents away from the IC. Note – if an input pi-filter (C, L, C) EMI filter is used then the inductor in the filter should be placed between the negative terminals of the input filter capacitors.

### Output SR Switch

For best performance, the area of the loop connecting the secondary winding, the output SR switch and the output filter capacitor, should be minimized.

### ESD

Sufficient clearance should be maintained ( $>8\ \text{mm}$ ) between the primary-side and secondary-side circuits to enable easy compliance with any ESD / HIPOT requirements.

The spark gap is best placed directly between output positive rail and one of the AC inputs. In this configuration a  $6.2\ \text{mm}$  spark gap is often sufficient to meet the creepage and clearance requirements of many applicable safety standards. This is less than the primary to secondary spacing because the voltage across spark gap does not exceed the peak of the AC input.

### Drain Node

The drain switching node is the dominant noise generator. As such the components connected the drain node should be placed close to the IC and away from sensitive feedback circuits. The clamp circuit components should be located physically away from the PRIMARY BYPASS pin and trace lengths minimized.

The loop area of the loop comprising of the input rectifier filter capacitor, the primary winding and the IC primary-side switch should be kept as small as possible.

## Recommendations for EMI Reduction

1. Appropriate component placement and small loop areas of the primary and secondary power circuits help minimize radiated and conducted EMI. Care should be taken to achieve a compact loop area.
2. A small capacitor in parallel to the clamp diode on the primary-side can help reduce radiated EMI.
3. A resistor in series with the bias winding helps reduce radiated EMI.
4. Common mode chokes are typically required at the input of the power supply to sufficiently attenuate common mode noise. However, the same performance can be achieved by using shield windings on the transformer. Shield windings can also be used in conjunction with common mode filter inductors at input to improve conducted and radiated EMI margins.
5. Adjusting SR switch RC snubber component values can help reduce high frequency radiated and conducted EMI.
6. A pi-filter comprising differential inductors and capacitors can be used in the input rectifier circuit to reduce low frequency differential EMI.
7. A 1  $\mu$ F ceramic capacitor connected at the output of the power supply helps to reduce radiated EMI.

## Recommendations for Transformer Design

Transformer design must ensure that the power supply delivers the rated power at the lowest input voltage. The lowest voltage on the rectified DC bus depends on the capacitance of the filter capacitor used. At least 2  $\mu$ F/W is recommended to always keep the DC bus voltage above 70 V, though 3  $\mu$ F/W provides sufficient margin. The ripple on the DC bus should be measured to confirm the design calculations for transformer primary-winding inductance selection.

### Switching Frequency ( $f_{sw}$ )

It is a unique feature in InnoSwitch4-QR IC that for full load, the designer can set the switching frequency to between 50 kHz to 140 kHz. For a smaller transformer, the full load switching frequency could be set to 130 kHz. When setting the full load switching frequency it is important to consider primary inductance and peak current tolerances to ensure that average switching frequency does not exceed 140 kHz which may trigger auto-restart due to overload protection.

### Reflected Output Voltage, $V_{OR}$ (V)

This parameter describes the effect on the primary switch drain voltage of the secondary-winding voltage during diode/SR conduction which is reflected back to the primary through the turns ratio of the transformer.

Consider the following for design optimization:

1. Higher  $V_{OR}$  allows increased power delivery at  $V_{MIN}$ , which minimizes the value of the input capacitor and maximizes power delivery from a given InnoSwitch4-QR device.
2. Higher  $V_{OR}$  reduces the voltage stress on the output diodes and SR switches.
3. Higher  $V_{OR}$  increases leakage inductance which reduces power supply efficiency.
4. Higher  $V_{OR}$  increases peak and RMS current on the secondary-side which may increase secondary-side copper and diode losses.

There are some exceptions to this. For very high output currents the  $V_{OR}$  should be reduced to get highest efficiency. For output voltages above 15 V,  $V_{OR}$  should be higher to maintain an acceptable PIV across the output synchronous rectifier.

### Ripple to Peak Current Ratio, $K_p$

A  $K_p$  below 1 indicates continuous conduction mode, where  $K_p$  is the ratio of ripple-current to peak-primary-current (Figure 17).

$$K_p \equiv K_{RP} = I_R / I_P$$

A value of  $K_p$  higher than 1, indicates discontinuous conduction mode (Figure 18). In this case  $K_p$  is the ratio of primary switch off-time to the secondary diode conduction-time.

$$K_p \equiv K_{DP} = (1 - D) \times T / t = V_{OR} \times (1 - D_{MAX}) / ((V_{MIN} - V_{DS}) \times D_{MAX})$$

It is recommended that a  $K_p$  close to 0.7 at the minimum expected DC bus voltage should be used for most InnoSwitch4-QR designs.

For a typical USB PD and rapid charge designs which require a wide output voltage range,  $K_p$  will change significantly as the output voltage changes.  $K_p$  will be high for high output voltage conditions and will drop as the output voltage is lowered. The PIXIs spreadsheet can be used to effectively optimize selection of  $K_p$ , inductance of the primary winding, transformer turns ratio, and the operating frequency while ensuring appropriate design margins.

### Core Type

Choice of a suitable core is dependent on the physical limits of the power supply enclosure. It is recommended that only cores with low loss be used to reduce thermal challenges.

### Safety Margin, M (mm)

For designs that require safety isolation between primary and secondary that are not using triple insulated wire, the width of the safety margin to be used on each side of the bobbin is important. For universal input designs a total margin of 6.2 mm is typically required – 3.1 mm being used on either side of the winding. For vertical bobbins the margin may not be symmetrical. However if a total margin of 6.2 mm is required then the physical margin can be placed on only one side of the bobbin. For designs using triple insulated wire it may still be necessary to add a small margin in order to meet required creepage distances. Many bobbins exist for each core size and each will have different mechanical spacing. Refer to the bobbin data sheet or seek guidance to determine what specific margin is required. As the margin reduces the available area for the windings, the winding area will disproportionately reduce for small core sizes.

It is recommended that for compact power supply designs using an InnoSwitch4-QR IC, triple insulated wire should be used.

### Primary Layers, L

Primary layers should be in the range of  $1 \leq L \leq 3$  and in general should be the lowest number that meets the primary current density limit (CMA). A value of  $\geq 200$  Cmil / Amp can be used as a starting point for most designs. Higher values may be required due to thermal constraints. However for DCM only designs it is recommended to minimize leakage inductance. Designs with more than 3 layers are possible but the increased leakage inductance and the physical fit of the windings should be considered. A split primary construction may be helpful for DCM only designs. In split primary construction, half of the primary winding is placed on either side of the secondary (and bias) winding in a sandwich arrangement. This arrangement is often disadvantageous for low power designs as this typically increases common mode noise and adds cost to the input filtering.

## Maximum Operating Flux Density, $B_M$ (Gauss)

A maximum value of 3800 gauss at the peak device current limit (at 180 kHz) is recommended to limit the peak flux density at start-up and under output short-circuit conditions. Under these conditions the output voltage is low and little reset of the transformer occurs during the switch off-time. This allows the transformer flux density to staircase beyond the normal operating level. A value of 3800 gauss at the peak current limit of the selected device together with the built-in protection features of InnoSwitch4-QR IC provide sufficient margin to prevent core saturation under start-up or output short-circuit conditions.

## Transformer Primary Inductance, (LP)

Once the lowest operating input voltage, switching frequency at full load, and required VOR are determined, the transformers primary inductance can be calculated. The PIXIs design spreadsheet can be used to assist in designing the transformer.

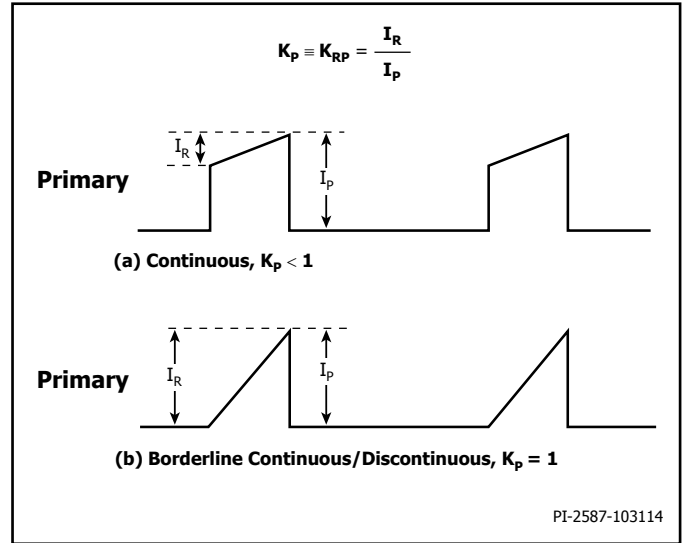

Figure 17. Continuous Conduction Mode Current Waveform,  $K_p < 1$ .

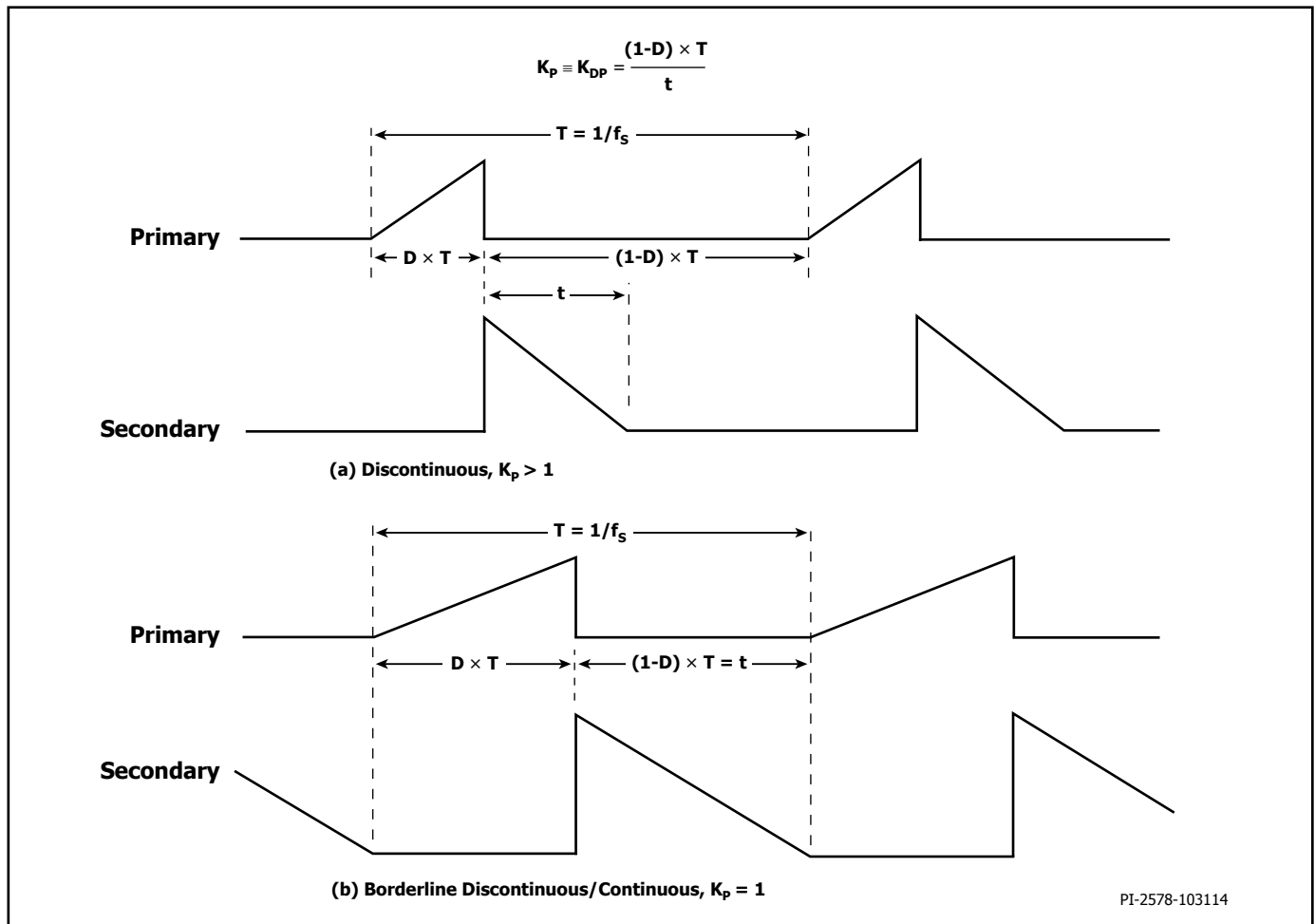

Figure 18. Discontinuous Conduction Mode Current Waveform,  $K_p > 1$ .

## Quick Design Checklist

As with any power supply, the operation of all InnoSwitch4-QR designs should be verified on the bench to make sure that component limits are not exceeded under worst-case conditions.

As a minimum, the following tests are strongly recommended:

1. Maximum Drain Voltage – Verify that  $V_{DS}$  of InnoSwitch4-QR IC does not exceed the maximum continuous drain voltage and SR FET do not exceed 90% of breakdown voltages at the highest input voltage and peak (overload) output power in normal operation and during start-up.
2. Maximum Drain Current – At maximum ambient temperature, maximum input voltage and peak output (overload) power. Review drain current waveforms for any signs of transformer saturation or excessive leading-edge current spikes at start-up. Repeat tests under steady-state conditions and verify that the leading edge current spike is below  $I_{LIMIT(MIN)}$  at the end of  $t_{LEB(MIN)}$ . Under all conditions, the maximum drain current for the primary switch should be below the specified absolute maximum ratings.
3. Thermal Check – At specified maximum output power, minimum input voltage and maximum ambient temperature, verify that temperature specification limits for InnoSwitch4-QR IC, transformer, output SR FET, and output capacitors are not exceeded. Enough thermal margin should be allowed for part-to-part variation of the  $R_{DS(ON)}$  of the InnoSwitch4-QR IC. Under low-line, maximum power, a maximum InnoSwitch4-QR SOURCE pin temperature of 110 °C is recommended to allow for these variations.

## Design Considerations When Using PowiGaN Devices

For a flyback converter configuration, typical voltage waveform at the DRAIN pin of the IC is shown in Figure 19.

$V_{OR}$  is the reflected output voltage across the primary winding when the secondary is conducting.  $V_{BUS}$  is the DC voltage connected to one end of the transformer primary winding.

In addition to  $V_{BUS} + V_{OR}$ , the drain also sees a large voltage spike at turn off that is caused by the energy stored in the leakage inductance of the primary winding. To keep the drain voltage from exceeding the rated maximum continuous drain voltage, a clamp circuit is needed across the primary winding. The forward recovery of the clamp diode

will add a spike at the instant of turn-OFF of the primary switch.  $V_{CLM}$  in Figure 21 is the combined clamp voltage including the spike. The peak drain voltage of the primary switch is the total of  $V_{BUS}$ ,  $V_{OR}$  and  $V_{CLM}$ .  $V_{OR}$  and the clamp voltage  $V_{CLM}$  should be selected such that the peak drain voltage is lower than 650 V for all normal operating conditions. This provides sufficient margin to ensure that occasional increase in voltage during line transients such as line surges will maintain the peak drain voltage well below 750 V under abnormal transient operating conditions. This ensures excellent long term reliability and design margin.

Consider the following for design optimization:

1. Higher  $V_{OR}$  allows increased power delivery at  $V_{MIN}$ , which minimizes the value of the input capacitor and maximizes power delivery from a given PowiGaN device.
2. Higher  $V_{OR}$  reduces the voltage stress on the output diodes and SR FETs.
3. Higher  $V_{OR}$  increases leakage inductance which reduces power supply efficiency.
4. Higher  $V_{OR}$  increases peak and RMS current on the secondary-side which may increase secondary-side copper and diode losses.

There are some exceptions to this. For very high output currents the  $V_{OR}$  should be reduced to get highest efficiency. For output voltages above 15 V,  $V_{OR}$  should be maintained higher to maintain an acceptable PIV across the output synchronous rectifier.

$V_{OR}$  choice will affect the operating efficiency and should be selected carefully. Table below shows the typical range of  $V_{OR}$  for optimal performance:

Output Voltage	Optimal Range for $V_{OR}$
5 V	45 - 70
12 V	80 - 120
15 V	100 - 135
20 V	120 - 160
24 V	135 - 180
28 V	150 - 200

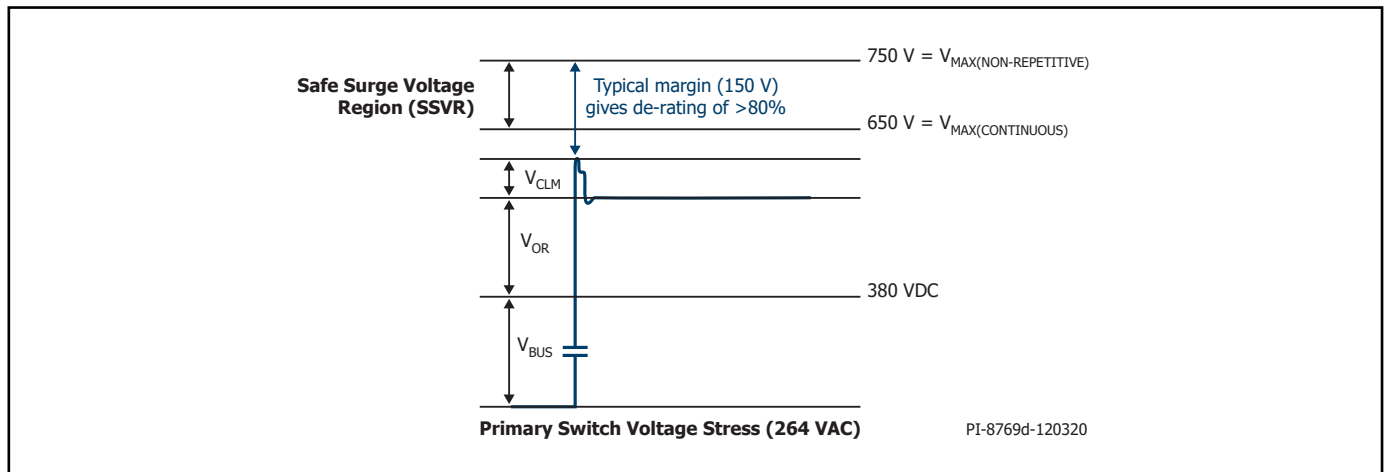

Figure 19. Peak Drain Voltage for 264 VAC Input Voltage.



Parameter	Symbol	Conditions		Min	Typ	Max	Units
		SOURCE = 0 V T <sub>J</sub> = -40 °C to 125 °C (Unless Otherwise Specified)					
<b>Control Functions</b>							
<b>Start-Up Switching Frequency</b>	f <sub>SW</sub>	T <sub>J</sub> = 25 °C		23	25	27	kHz
<b>Jitter Modulation Frequency</b>	f <sub>M</sub>	T <sub>J</sub> = 25 °C, f <sub>SW</sub> = 100 kHz	INN4276C-7C INN477xC	150	250	400	Hz
			INN4274C-5C	0.83	1.25	1.70	kHz
<b>Maximum On-Time</b>	t <sub>ON(MAX)</sub>	T <sub>J</sub> = 25 °C		13	16.5	21.5	μs
<b>Minimum Primary Feedback Block-Out Timer</b>	t <sub>BLOCK</sub>					t <sub>OFF(MIN)</sub>	μs
<b>BPP Supply Current</b>	I <sub>S1</sub>	V <sub>BPP</sub> = V <sub>BPP</sub> + 0.1 V (Switch not Switching) T <sub>J</sub> = 25 °C		145	300	425	μA
	I <sub>S2</sub>	V <sub>BPP</sub> = V <sub>BPP</sub> + 0.1 V (Switch Switching at 180 kHz) T <sub>J</sub> = 25 °C	INN4274C	2.2	3.20	3.70	mA
			INN4275C	2.2	3.20	3.70	
			INN4276C	3.43	4.29	5.15	
			INN4277C	3.44	4.30	5.16	
			INN4774C	2.36	2.95	3.54	
			INN4775C	2.36	2.96	3.55	
			INN4776C	3.36	4.20	5.04	
INN4777C	3.43	4.29	5.15				
<b>BPP Pin Charge Current</b>	I <sub>CH1</sub>	V <sub>BP</sub> = 0 V, T <sub>J</sub> = 25 °C		-1.75	-1.35	-0.88	mA
	I <sub>CH2</sub>	V <sub>BP</sub> = 4 V, T <sub>J</sub> = 25 °C		-5.98	-4.65	-3.28	
<b>BPP Pin Voltage</b>	V <sub>BPP</sub>	T <sub>J</sub> = 25 °C		4.8	5	5.16	V
<b>BPP Pin Voltage Hysteresis</b>	V <sub>BPP(H)</sub>	T <sub>J</sub> = 25 °C			0.5		V
<b>BPP Shunt Voltage</b>	V <sub>SHUNT</sub>	I <sub>BPP</sub> = 2 mA		5.16	5.36	5.7	V
<b>BPP Power-Up Reset Threshold Voltage</b>	V <sub>BPP(RESET)</sub>	T <sub>J</sub> = 25 °C		2.8	3.15	3.5	V
<b>UV/OV Pin Brown-In Threshold</b>	I <sub>UV+</sub>	T <sub>J</sub> = 25 °C	INN427xC	23.1	25.2	27.5	μA
			INN477xC	50.9	55.5	60.6	
<b>UV/OV Pin Brown-Out Threshold</b>	I <sub>UV-</sub>	T <sub>J</sub> = 25 °C	INN427xC	20.5	23	25	μA
			INN477xC	42.5	47.0	51.1	



Parameter	Symbol	Conditions			Min	Typ	Max	Units
		SOURCE = 0 V T <sub>j</sub> = -40 °C to 125 °C (Unless Otherwise Specified)						
<b>Control Functions (cont.)</b>								
Brown-Out Delay Time	t <sub>UV-</sub>	T <sub>j</sub> = 25 °C				35		ms
UV/OV Pin Line Overvoltage Threshold	I <sub>OV+</sub>	T <sub>j</sub> = 25 °C			106	115	118	μA
UV/OV Pin Line Overvoltage Hysteresis	I <sub>OV(H)</sub>	T <sub>j</sub> = 25 °C				8		μA
UV/OV Pin Line Overvoltage Recovery Threshold	I <sub>OV-</sub>	T <sub>j</sub> = 25 °C			100			μA
<b>Line Fault Protection</b>								
VOLTAGE Pin Line Overvoltage Deglitch Filter	t <sub>OV+</sub>	T <sub>j</sub> = 25 °C See Note B				3		μs
VOLTAGE Pin Voltage Rating	V <sub>V</sub>	T <sub>j</sub> = 25 °C			650			V

Parameter	Symbol	Conditions		Min	Typ	Max	Units
		SOURCE = 0 V T <sub>J</sub> = -40 °C to 125 °C (Unless Otherwise Specified)					
<b>Circuit Protection</b>							
<b>Standard Current Limit (BPP) Capacitor = 0.47 μF</b>	I <sub>LIMIT</sub> (Switch switching at 100 kHz)	di/dt = 475 mA/μs T <sub>J</sub> = 25 °C	INN4274C	1953	2100	2247	mA
		di/dt = 500 mA/μs T <sub>J</sub> = 25 °C	INN4275C	2139	2300	2461	
		di/dt = 660 mA/μs T <sub>J</sub> = 25 °C	INN4276C	2697	2900	3103	
		di/dt = 770 mA/μs T <sub>J</sub> = 25 °C	INN4277C	3162	3400	3638	
		di/dt = 1200 mA/μs T <sub>J</sub> = 25 °C	INN4774C	3348	3600	3852	
		di/dt = 1300 mA/μs T <sub>J</sub> = 25 °C	INN4775C	3534	3800	4066	
		di/dt = 1600 mA/μs T <sub>J</sub> = 25 °C	INN4776C	3906	4200	4494	
		di/dt = 1700 mA/μs T <sub>J</sub> = 25 °C	INN4777C	4278	4600	4922	
<b>Increased Current Limit (BPP) Capacitor = 4.7 μF</b>	I <sub>LIMIT+1</sub> (Switch switching at 100 kHz)	di/dt = 475 mA/μs T <sub>J</sub> = 25 °C	INN4274C	2162	2350	2538	mA
		di/dt = 500 mA/μs T <sub>J</sub> = 25 °C	INN4275C	2374	2580	2786	
		di/dt = 660 mA/μs T <sub>J</sub> = 25 °C	INN4276C	2990	3250	3510	
		di/dt = 770 mA/μs T <sub>J</sub> = 25 °C	INN4277C	3505	3810	4115	
		di/dt = 1200 mA/μs T <sub>J</sub> = 25 °C	INN4774C	3708	4030	4352	
		di/dt = 1300 mA/μs T <sub>J</sub> = 25 °C	INN4775C	3919	4260	4601	
		di/dt = 1600 mA/μs T <sub>J</sub> = 25 °C	INN4776C	4324	4700	5076	
		di/dt = 1700 mA/μs T <sub>J</sub> = 25 °C	INN4777C	4738	5150	5562	

Parameter	Symbol	Conditions			Min	Typ	Max	Units
		SOURCE = 0 V T <sub>j</sub> = -40 °C to 125 °C (Unless Otherwise Specified)						
<b>Circuit Protection (cont.)</b>								
Overload Detection Frequency	f <sub>OVL</sub>	T <sub>j</sub> = 25 °C	INN4273C-5C	130	140	151	kHz	
			INN4276C-7C INN477xC	143	155	167		
BYPASS Pin Latching Shutdown Threshold Current	I <sub>SD</sub>	T <sub>j</sub> = 25 °C		6.0	7.5	11.3	mA	
Auto-Restart On-Time	t <sub>AR</sub>	T <sub>j</sub> = 25 °C		75	82	89	ms	
Auto-Restart Trigger Skip Time	t <sub>AR(SK)</sub>	T <sub>j</sub> = 25 °C See Note A			1.3		sec	
Auto-Restart Off-Time	t <sub>AR(OFF)</sub>	T <sub>j</sub> = 25 °C		1.70	2.00	2.11	sec	
Short Auto-Restart Off-Time	t <sub>AR(OFF)SH</sub>	T <sub>j</sub> = 25 °C			0.20		sec	

Parameter	Symbol	Conditions		Min	Typ	Max	Units			
		SOURCE = 0 V T <sub>j</sub> = -40 °C to 125 °C (Unless Otherwise Specified)								
<b>Output</b>										
<b>ON-State Resistance</b>	R <sub>DS(ON)</sub>	INN4274C I <sub>D</sub> = I <sub>LIMIT+1</sub>	T <sub>j</sub> = 25 °C		0.35	0.44	Ω			
			T <sub>j</sub> = 100 °C		0.49	0.62				
		INN4275C I <sub>D</sub> = I <sub>LIMIT+1</sub>	T <sub>j</sub> = 25 °C		0.29	0.39				
			T <sub>j</sub> = 100 °C		0.41	0.54				
		INN4276C I <sub>D</sub> = I <sub>LIMIT+1</sub>	T <sub>j</sub> = 25 °C		0.18	0.28				
			T <sub>j</sub> = 100 °C		0.27	0.37				
		INN4277C I <sub>D</sub> = I <sub>LIMIT+1</sub>	T <sub>j</sub> = 25 °C		0.145	0.21				
			T <sub>j</sub> = 100 °C		0.23	0.29				
		INN4774C I <sub>D</sub> = I <sub>LIMIT+1</sub>	T <sub>j</sub> = 25 °C		0.35	0.44				
			T <sub>j</sub> = 100 °C		0.49	0.62				
		INN4775C I <sub>D</sub> = I <sub>LIMIT+1</sub>	T <sub>j</sub> = 25 °C		0.29	0.39				
			T <sub>j</sub> = 100 °C		0.41	0.54				
		INN4776C I <sub>D</sub> = I <sub>LIMIT+1</sub>	T <sub>j</sub> = 25 °C		0.18	0.28				
			T <sub>j</sub> = 100 °C		0.27	0.37				
		INN4777C I <sub>D</sub> = I <sub>LIMIT+1</sub>	T <sub>j</sub> = 25 °C		0.145	0.21				
			T <sub>j</sub> = 100 °C		0.23	0.29				
		<b>OFF-State Drain Leakage Current</b>	I <sub>DSS1</sub>	V <sub>BPP</sub> = V <sub>BPP</sub> + 0.1 V V <sub>DS</sub> = 80% Peak Drain Voltage T <sub>j</sub> = 125 °C					200	μA
			I <sub>DSS2</sub>	V <sub>BPP</sub> = V <sub>BPP</sub> + 0.1 V V <sub>DS</sub> = 325 V T <sub>j</sub> = 25 °C				15		μA
<b>Thermal Shutdown</b>	T <sub>SD</sub>	See Note A		135	142	150	°C			
<b>Thermal Shutdown Hysteresis</b>	T <sub>SD(H)</sub>	See Note A			70		°C			
<b>Drain Supply Voltage</b>				50			V			

Parameter	Symbol	Conditions	Min	Typ	Max	Units
		SOURCE = 0 V T <sub>J</sub> = -40 °C to 125 °C (Unless Otherwise Specified)				
<b>Secondary</b>						
<b>FEEDBACK Pin Voltage</b>	V <sub>FB</sub>	T <sub>J</sub> = 25 °C	1.250	1.265	1.280	V
<b>Maximum Switching Frequency</b>	f <sub>SREQ</sub>	T <sub>J</sub> = 25 °C	164	180	194	kHz
<b>OUTPUT VOLTAGE Pin Auto-Restart Timer</b>	t <sub>FB(AR)</sub> t <sub>VOUT(AR)</sub> t <sub>IS(AR)</sub>	T <sub>J</sub> = 25 °C		50		ms
<b>BPS Pin Current at No-Load</b>	I <sub>SNL</sub>	T <sub>J</sub> = 25 °C		380	485	μA
<b>BPS Pin Voltage</b>	V <sub>BPS</sub>		4.3	4.5	4.7	V
<b>BPS Pin Undervoltage Threshold</b>	V <sub>BPS(UVLO)(TH)</sub>		3.60	3.80	4.00	V
<b>BPS Pin Undervoltage Hysteresis</b>	V <sub>BPS(UVLO)(H)</sub>			0.7		V
<b>Current Limit Voltage Threshold</b>	I <sub>SV(TH)</sub>	Set by External Resistor T <sub>J</sub> = 25 °C	35.17	36	36.62	mV
<b>FWD Pin Breakdown Voltage</b>	V <sub>PWD</sub>		150			V
<b>Minimum Off-Time</b>	t <sub>OFF(MIN)</sub>		1.76	1.9	2.03	μs
<b>BPS Pin Latch Command Shutdown Threshold Current</b>	I <sub>BPS(SD)</sub>		6	8.9	12	mA
<b>FEEDBACK Pin Short-Circuit</b>	V <sub>FB(OFF)</sub>	T <sub>J</sub> = 25 °C		100		mV

Parameter	Symbol	Conditions			Min	Typ	Max	Units
		SOURCE = 0 V T <sub>J</sub> = -40 °C to 125 °C (Unless Otherwise Specified)						
<b>Synchronous Rectifier @ T<sub>J</sub> = 25 °C</b>								
SR Pin Drive Voltage	V <sub>SR</sub>			4.3	4.5	4.7	V	
SR Pin Voltage Threshold	V <sub>SR(TH)</sub>				-6	0	mV	
SR Pin Pull-Up Current	I <sub>SR(PU)</sub>	T <sub>J</sub> = 25 °C C <sub>LOAD</sub> = 2 nF, f <sub>SW</sub> = 100 kHz		125	165	195	mA	
SR Pin Pull-Down Current	I <sub>SR(PD)</sub>	T <sub>J</sub> = 25 °C C <sub>LOAD</sub> = 2 nF, f <sub>SW</sub> = 100 kHz		315	365	415	mA	
Rise Time	t <sub>R</sub>	T <sub>J</sub> = 25 °C C <sub>LOAD</sub> = 2 nF See Note B	10-90%		50		ns	
Fall Time	t <sub>F</sub>	T <sub>J</sub> = 25 °C C <sub>LOAD</sub> = 2 nF See Note B	90-10%		25		ns	
Output Pull-Up Resistance	R <sub>PU</sub>	T <sub>J</sub> = 25 °C V <sub>BPS</sub> = 4.4 V I <sub>SR</sub> = 10 mA		6	8.9	10.5	Ω	
Output Pull-Down Resistance	R <sub>PD</sub>	T <sub>J</sub> = 25 °C V <sub>BPS</sub> = 4.4 V I <sub>SR</sub> = 10 mA		2.4	3.3	5	Ω	

**NOTES:**

- A. This parameter is derived from characterization.
- B. This parameter is guaranteed by design.
- C. To ensure correct current limit it is recommended that nominal 0.47 μF / 4.7 μF capacitors are used. In addition, the BPP capacitor value tolerance should be equal or better than indicated below across the ambient temperature range of the target application. The minimum and maximum capacitor values are guaranteed by characterization.

Nominal BPP Pin Capacitor Value	BPP Capacitor Minimum	Value Tolerance Maximum
0.47 μF	-60%	+100%
4.7 μF	-50%	N/A

Recommended to use at least 10 V / 0805 / X7R SMD MLCC.



## Typical Performance Curves

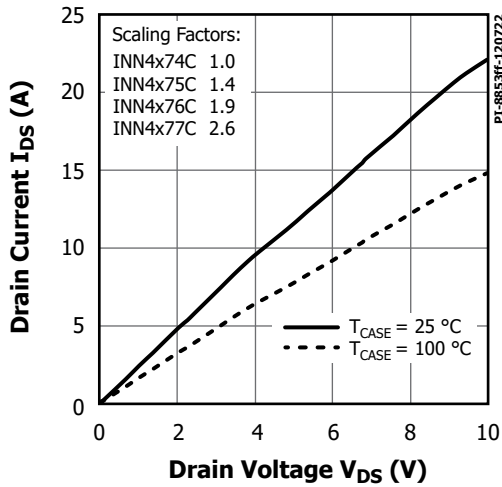

Figure 20. Output Characteristics.

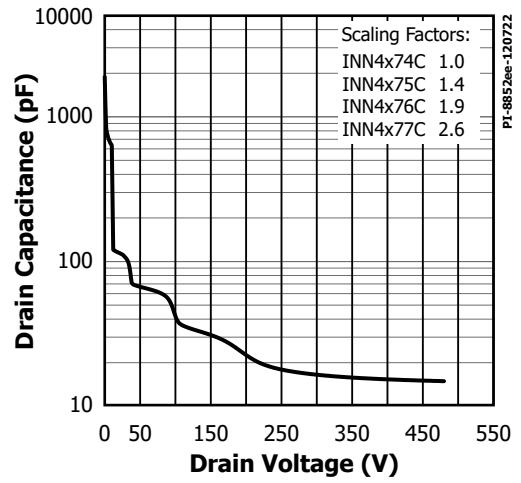

Figure 21.  $C_{oss}$  vs. Drain Voltage.

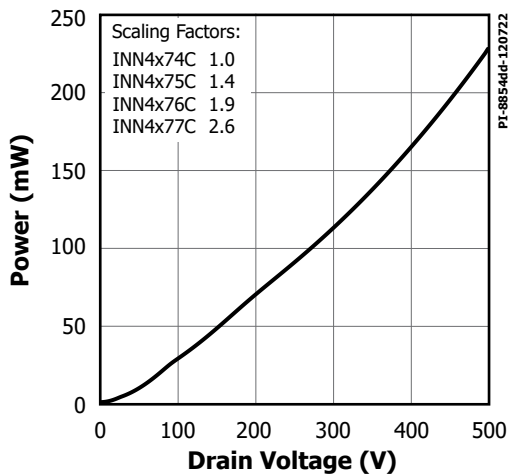

Figure 22. Drain Capacitance Power.

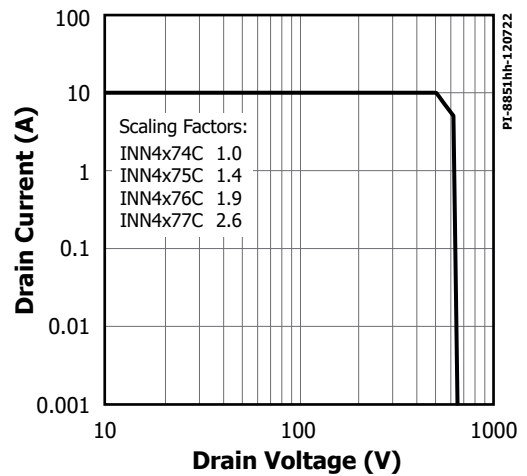

Figure 23. Maximum Allowable Drain Current vs. Drain Voltage.

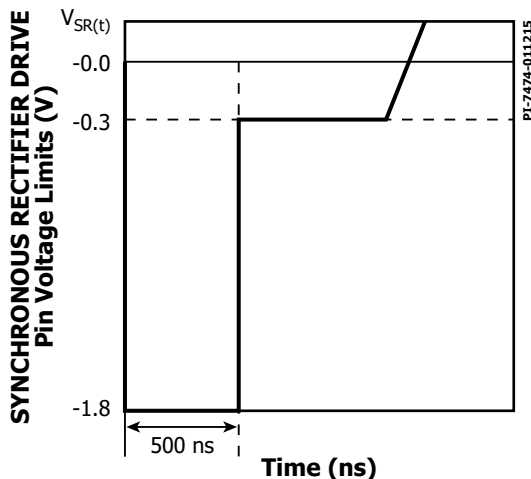

Figure 24. SYNCHRONOUS RECTIFIER DRIVE Pin Negative Voltage.

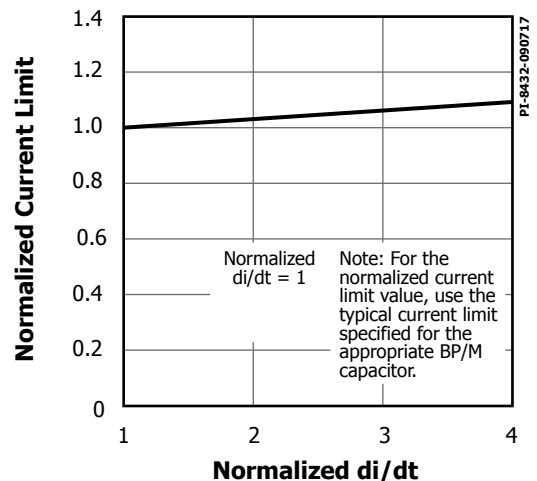

Figure 25. Standard Current Limit vs.  $di/dt$ .

InSOP-24D



Notes:

1. Dimensioning and Tolerancing per ASME Y14.5M - 1994.

2. Dimensions noted are determined at the outermost extremes of the plastic body exclusive of mold flash, tie bar burrs, gate burrs, and interlead flash, but including any mismatch between the top and bottom of the plastic body. Maximum mold protrusion is 0.18 [0.007] per side.
3. Dimensions noted are inclusive of plating thickness.
4. Does not include inter-lead flash or protrusions.
5. Controlling dimensions in millimeters [inches].
6. Datums A & B to be determined at Datum H.

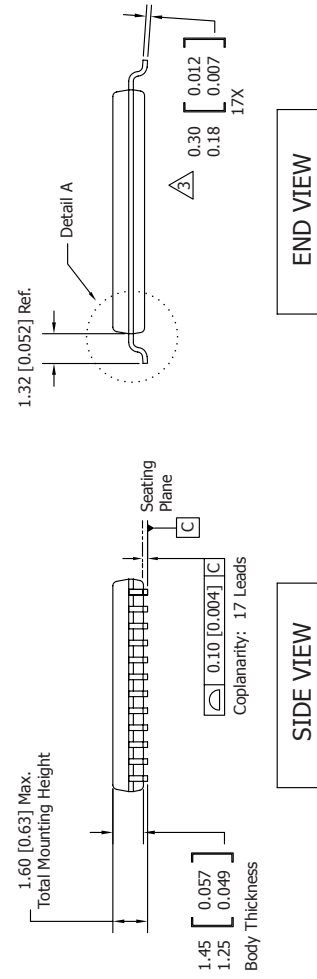

**PACKAGE MARKING**

**InSOP-24D**

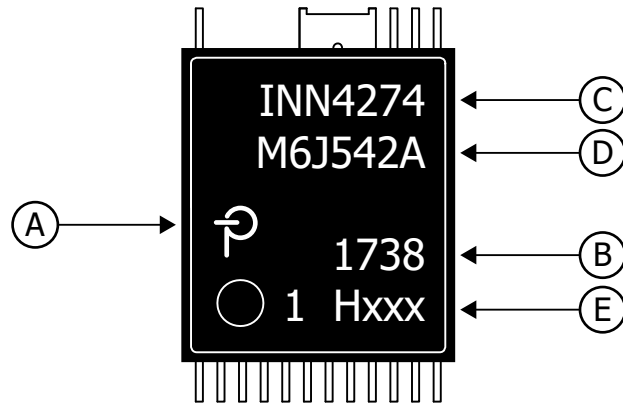

- A. Power Integrations Registered Trademark
- B. Assembly Date Code (last two digits of year followed by 2-digit work week)
- C. Product Identification (Part #/Package Type)
- D. Lot Identification Code
- E. Test Sublot and Feature Code

PI-8727p-120822

Parameter	Conditions	Rating	Units
<b>Ratings for UL1577</b>			
<b>Primary-Side Current Rating</b>	Current from pin (16-19) to pin 24	0.6	A
<b>Primary-Side Power Rating</b>	$T_{AMB} = 25\text{ °C}$ (Device mounted in socket resulting in $T_{CASE} = 120\text{ °C}$ )	1.35	W
<b>Secondary-Side Power Rating</b>	$T_{AMB} = 25\text{ °C}$ (Device mounted in socket)	0.125	W
<b>Package Characteristics</b>			
<b>Clearance</b>		11.4	mm (min)
<b>Creepage</b>		11.4	mm (min)
<b>Distance Through Insulation (DTI)</b>		0.4	mm
<b>Transient Isolation Voltage</b>		6	kV (min)
<b>Comparative Tracking Index (CTI)</b>		>600	V

**Feature Code Table for INN427xC**

Feature Code	AR Threshold	OTP Response	AR and OVL Response	Output Profile	V <sub>OUT</sub> OVP	Secondary Fault Response	Line OV/UV
H181	63%	Hysteretic	AR	Fixed CC	Enable	AR	Enabled / Enable
H182	3.45 V	Latch-Off	AR	Fixed CC	–	Latch-Off	Enabled / Enable
H183	63%	Latch-Off	Latch-Off	Fixed CC	–	Latch-Off	Enabled / Enable
H184*	90%	Hysteretic	AR	Fixed CC	Enable	AR	Disable / Enable
H185	OL	Hysteretic	AR	CV only	Enable	AR	Enabled / Enable
H186	OL	Hysteretic	AR	CV only	Enable	Latch-Off	Disabled / Enable

\*Not available on INN4274/75.

**Feature Code Table for INN477xC**

Feature Code	AR Threshold	OTP Response	AR and OVL Response	Output Profile	V <sub>OUT</sub> OVP	Secondary Fault Response	Line OV/UV	Brown-In Threshold	DCM Only
H187	63%	Hysteretic	AR	Fixed CC	–	AR	Enable / Enable	200 V Nominal*	Disable
H188	3.45 V	Latch-Off	AR	Fixed CC	–	Latch-Off	Enable / Enable	100 V Nominal*	Enable
H189	63%	Latch-Off	Latch-Off	Fixed CC	–	Latch-Off	Enable / Enable	200 V Nominal*	Enable
H190	90%	Hysteretic	AR	Fixed CC	–	AR	Disable / Enable	Programmable	Enable
H191	OL	Hysteretic	AR	CV only	Enable	AR	Enable / Enable	200 V Nominal*	Disable
H192	OL	Hysteretic	AR	CV only	–	Latch-Off	Disable / Enable	Programmable	Disable

\*4 Mohm V Pin Resistor.

**Part Ordering Information**

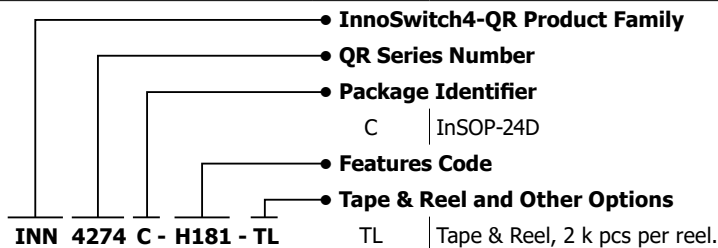

Revision	Notes	Date
A	Production release.	10/23
B	Updated $I_{S2}$ and $f_M$ spec on page 20.	02/24

### For the latest updates, visit our website: [www.power.com](http://www.power.com)

Power Integrations reserves the right to make changes to its products at any time to improve reliability or manufacturability. Power Integrations does not assume any liability arising from the use of any device or circuit described herein. POWER INTEGRATIONS MAKES NO WARRANTY HEREIN AND SPECIFICALLY DISCLAIMS ALL WARRANTIES INCLUDING, WITHOUT LIMITATION, THE IMPLIED WARRANTIES OF MERCHANTABILITY, FITNESS FOR A PARTICULAR PURPOSE, AND NON-INFRINGEMENT OF THIRD PARTY RIGHTS.

### Patent Information

The products and applications illustrated herein (including transformer construction and circuits external to the products) may be covered by one or more U.S. and foreign patents, or potentially by pending U.S. and foreign patent applications assigned to Power Integrations. A complete list of Power Integrations patents may be found at [www.power.com](http://www.power.com). Power Integrations grants its customers a license under certain patent rights as set forth at [www.power.com/ip.htm](http://www.power.com/ip.htm).

### Life Support Policy

POWER INTEGRATIONS PRODUCTS ARE NOT AUTHORIZED FOR USE AS CRITICAL COMPONENTS IN LIFE SUPPORT DEVICES OR SYSTEMS WITHOUT THE EXPRESS WRITTEN APPROVAL OF THE PRESIDENT OF POWER INTEGRATIONS. As used herein:

1. A Life support device or system is one which, (i) is intended for surgical implant into the body, or (ii) supports or sustains life, and (iii) whose failure to perform, when properly used in accordance with instructions for use, can be reasonably expected to result in significant injury or death to the user.
2. A critical component is any component of a life support device or system whose failure to perform can be reasonably expected to cause the failure of the life support device or system, or to affect its safety or effectiveness.

Power Integrations, the Power Integrations logo, CAPZero, ChiPhy, CHY, DPA-Switch, EcoSmart, E-Shield, eSIP, eSOP, HiperLCS, HiperPLC, HiperPFS, HiperTFS, InnoSwitch, Innovation in Power Conversion, InSOP, LinkSwitch, LinkZero, LYTSwitch, SENZero, TinySwitch, TOPSwitch, PI, PI Expert, PowiGaN, SCALE, SCALE-1, SCALE-2, SCALE-3 and SCALE-iDriver, are trademarks of Power Integrations, Inc. Other trademarks are property of their respective companies. ©2023, Power Integrations, Inc.

---

### Power Integrations Worldwide Sales Support Locations

#### World Headquarters

5245 Hellyer Avenue  
San Jose, CA 95138, USA  
Main: +1-408-414-9200  
Customer Service:  
Worldwide: +1-65-635-64480  
Americas: +1-408-414-9621  
e-mail: [usasales@power.com](mailto:usasales@power.com)

#### China (Shanghai)

Rm 2410, Charity Plaza, No. 88  
North Caoxi Road  
Shanghai, PRC 200030  
Phone: +86-21-6354-6323  
e-mail: [chinasales@power.com](mailto:chinasales@power.com)

#### China (Shenzhen)

17/F, Hivac Building, No. 2, Keji Nan  
8th Road, Nanshan District,  
Shenzhen, China, 518057  
Phone: +86-755-8672-8689  
e-mail: [chinasales@power.com](mailto:chinasales@power.com)

#### Germany

(AC-DC/LED/Motor Control Sales)  
Einsteinring 37  
85609 Dornach/Aschheim  
Germany  
Tel: +49-89-5527-39100  
e-mail: [eurosales@power.com](mailto:eurosales@power.com)

#### Germany (Gate Driver Sales)

HellwegForum 3  
59469 Ense  
Germany  
Tel: +49-2938-64-39990  
e-mail: [igbt-driver.sales@power.com](mailto:igbt-driver.sales@power.com)

#### India

#1, 14th Main Road  
Vasanthanagar  
Bangalore-560052 India  
Phone: +91-80-4113-8020  
e-mail: [indiasales@power.com](mailto:indiasales@power.com)

#### Italy

Via Milanese 20, 3rd. Fl.  
20099 Sesto San Giovanni (MI) Italy  
Phone: +39-024-550-8701  
e-mail: [eurosales@power.com](mailto:eurosales@power.com)

#### Japan

Yusen Shin-Yokohama 1-chome Bldg.  
1-7-9, Shin-Yokohama, Kohoku-ku  
Yokohama-shi,  
Kanagawa 222-0033 Japan  
Phone: +81-45-471-1021  
e-mail: [japansales@power.com](mailto:japansales@power.com)

#### Korea

RM 602, 6FL  
Korea City Air Terminal B/D, 159-6  
Samsung-Dong, Kangnam-Gu,  
Seoul, 135-728, Korea  
Phone: +82-2-2016-6610  
e-mail: [koreasales@power.com](mailto:koreasales@power.com)

#### Singapore

51 Newton Road  
#19-01/05 Goldhill Plaza  
Singapore, 308900  
Phone: +65-6358-2160  
e-mail: [singaporesales@power.com](mailto:singaporesales@power.com)

#### Taiwan

5F, No. 318, Nei Hu Rd., Sec. 1  
Nei Hu Dist.  
Taipei 11493, Taiwan R.O.C.  
Phone: +886-2-2659-4570  
e-mail: [taiwansales@power.com](mailto:taiwansales@power.com)

#### UK

Building 5, Suite 21  
The Westbrook Centre  
Milton Road  
Cambridge  
CB4 1YG  
Phone: +44 (0) 7823-557484  
e-mail: [eurosales@power.com](mailto:eurosales@power.com)

---