

SCALE™-2+ 2SC0108T

Preliminary Description & Application Manual

Dual Channel Ultra-compact Low-cost Driver Core

Abstract

The new low-cost SCALE™-2+ dual-driver core 2SC0108T combines unrivalled compactness with broad applicability. The driver was designed for universal applications requiring high reliability. The 2SC0108T drives all usual IGBT modules up to 600A/1200V or 450A/1700V. The embedded paralleling capability allows easy inverter design covering higher power ratings. Multi-level topologies are also supported.

The 2SC0108T is the most compact driver core available for industrial applications, with a footprint of only 45mm x 34.3mm and an insertion height of max. 16mm. It allows even the most restricted insertion spaces to be efficiently used.



Fig. 1 2SC0108T driver core

Preliminary Description & Application Manual

Contents

Abstract	1
Contents	2
Driver Overview	4
Mechanical Dimensions	5
Pin Designation	7
Recommended Interface Circuitry for the Primary Side Connector	8
Description of Primary Side Interface	8
General.....	8
VCC terminal	8
MOD (mode selection)	9
INA, INB (channel drive inputs, e.g. PWM).....	10
SO1, SO2 (status outputs).....	10
TB (input for adjusting the blocking time T_b).....	10
Recommended Interface Circuitry for the Secondary Side Connectors	11
Description of Secondary Side Interfaces	11
General.....	11
Emitter terminal (VEx).....	11
Reference terminals (REFx)	12
Collector sense (VCEx) with resistors.....	12
Desaturation protection with sense diodes	13
Disabling the $V_{CE,sat}$ detection.....	15
Gate turn-on (GHx) and turn-off (GLx) terminals	15
Active clamping	16
Soft Shut Down (SSD).....	16
How Do 2SC0108T SCALE-2+ Drivers Work in Detail?	17
Power supply and electrical isolation	17
Power-supply monitoring.....	17
Parallel connection of 2SC0108T	18
3-level or multilevel topologies.....	18
Additional application support for 2SC0108T	18
Electrical Ratings for UL recognized types	18
Bibliography	18
The Information Source: SCALE-2 and SCALE-2+ Driver Data Sheets	19

Preliminary Description & Application Manual

Quite Special: Customized SCALE-2 and SCALE-2+ Drivers	19
Technical Support	19
Quality	19
Legal Disclaimer	19
Ordering Information	20
Information about Other Products	20
Power Integrations Sales Offices	21

Preliminary Description & Application Manual

Driver Overview

The 2SC0108T is a driver core equipped with Power Integrations' latest SCALE-2+ chipset /1/. The SCALE-2+ chipset is a set of application-specific integrated circuits (ASICs) that cover the main range of functions needed to design intelligent gate drivers. The SCALE-2+ driver chipset is a further development of the proven SCALE technology /2/. The SCALE-2+ chipset further integrates the Soft Shut Down (SSD) feature described in the paragraph "Soft Shut Down (SSD)" on page 16.

The 2SC0108T targets low- and medium-power, dual-channel IGBT applications such as general purpose drives, UPS, solar converters and medical applications. The 2SC0108T comprises a complete dual-channel IGBT driver core, fully equipped with an isolated DC/DC converter, short-circuit protection and supply-voltage monitoring.

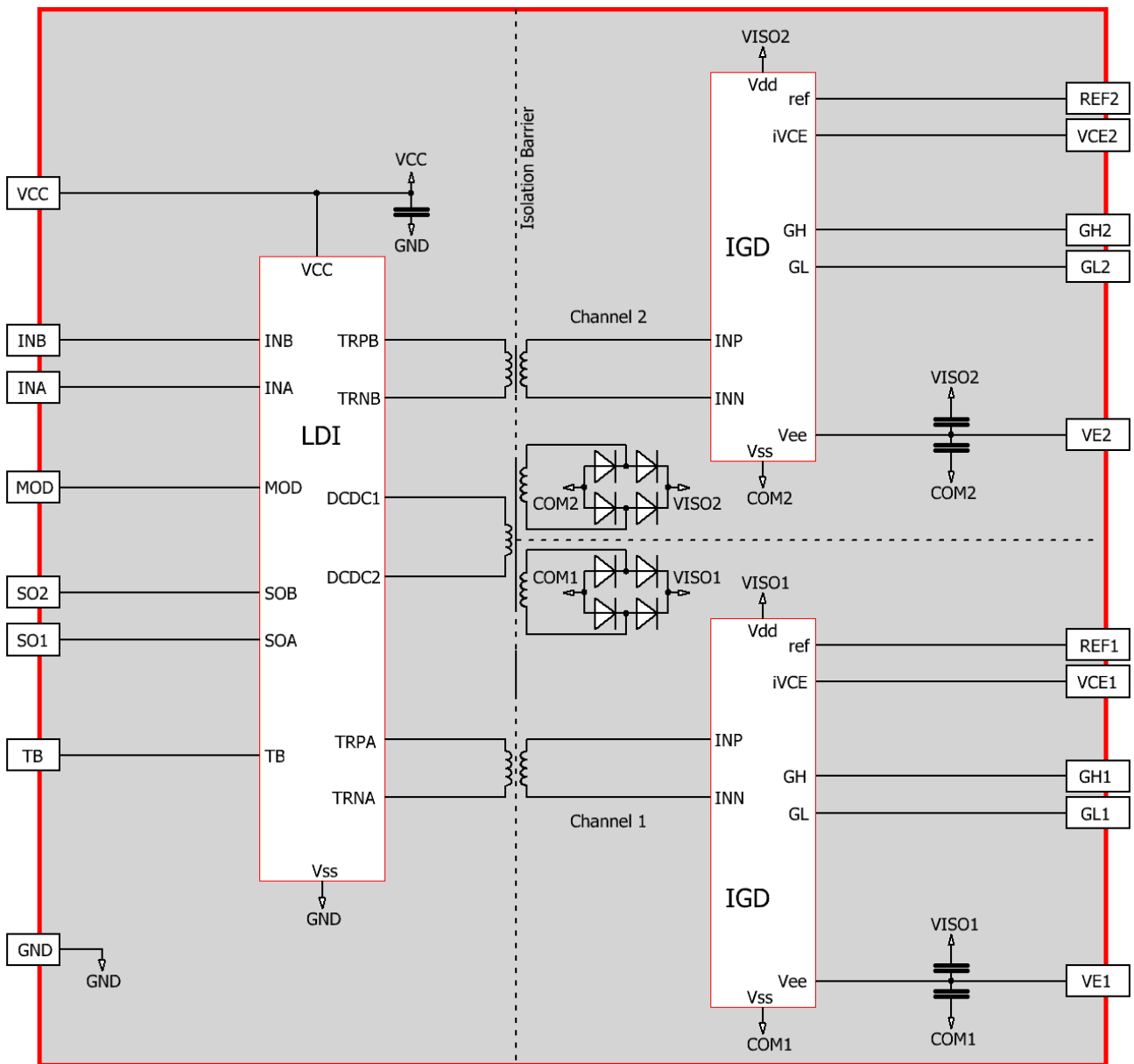

Fig. 2 Block diagram of the driver core 2SC0108T

Preliminary Description & Application Manual

Mechanical Dimensions

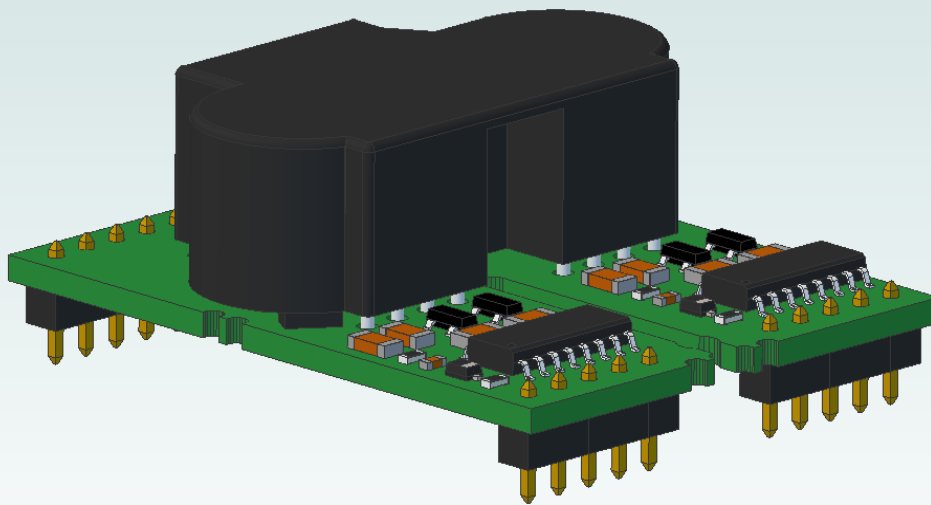

Fig. 3 Interactive 3D drawing of 2SC0108T2H0-17

Preliminary Description & Application Manual

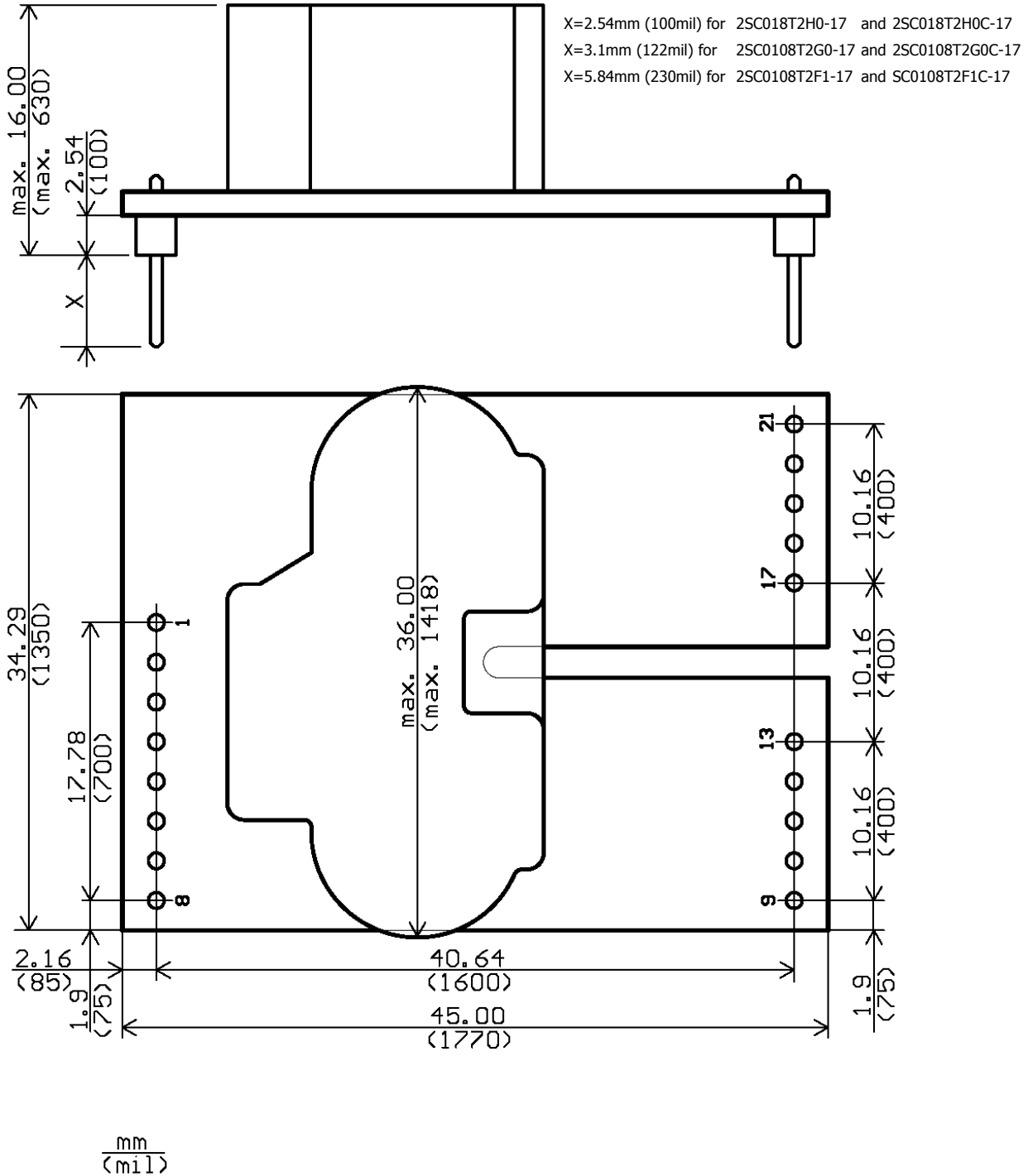

Fig. 4 Mechanical drawing of 2SC0108T

The primary side and secondary side pin grid is 2.54mm (100mil) with a pin cross section of 0.64mm x 0.64mm. Total outline dimensions of the board are 34.3mm x 45mm. The total height of the driver is max. 16mm measured from the bottom of the pin bodies to the top of the populated PCB.

Recommended diameter of solder pads: \varnothing 2mm (79 mil)
 Recommended diameter of drill holes: \varnothing 1mm (39 mil)

Preliminary Description & Application Manual

Pin Designation

Pin No. and Name	Function
Primary Side	
1 GND	Ground
2 INA	Signal input A; non-inverting input relative to GND
3 INB	Signal input B; non-inverting input relative to GND
4 VCC	Supply voltage; 15V supply for primary side
5 TB	Set blocking time
6 SO2	Status output channel 2; normally high-impedance, pulled down to low on fault
7 SO1	Status output channel 1; normally high-impedance, pulled down to low on fault
8 MOD	Mode selection (direct/half-bridge mode)
Secondary Sides	
9 GH1	Gate high channel 1; pulls gate high through turn-on resistor
10 VE1	Emitter channel 1; connect to (auxiliary) emitter of power switch
11 GL1	Gate low channel 1; pulls gate low through turn-off resistor
12 REF1	Set V_{CE} detection threshold voltage channel 1; resistor to VE1
13 VCE1	V_{CE} sense channel 1; connect to IGBT collector through resistor network
14 Free	
15 Free	
16 Free	
17 GH2	Gate high channel 2; pulls gate high through turn-on resistor
18 VE2	Emitter channel 2; connect to (auxiliary) emitter of power switch
19 GL2	Gate low channel 2; pulls gate low through turn-off resistor
20 REF2	Set V_{CE} detection threshold voltage channel 2; resistor to VE2
21 VCE2	V_{CE} sense channel 2; connect to IGBT collector through resistor network

Note: Pins with the designation "Free" are not physically present.

Preliminary Description & Application Manual

Recommended Interface Circuitry for the Primary Side Connector

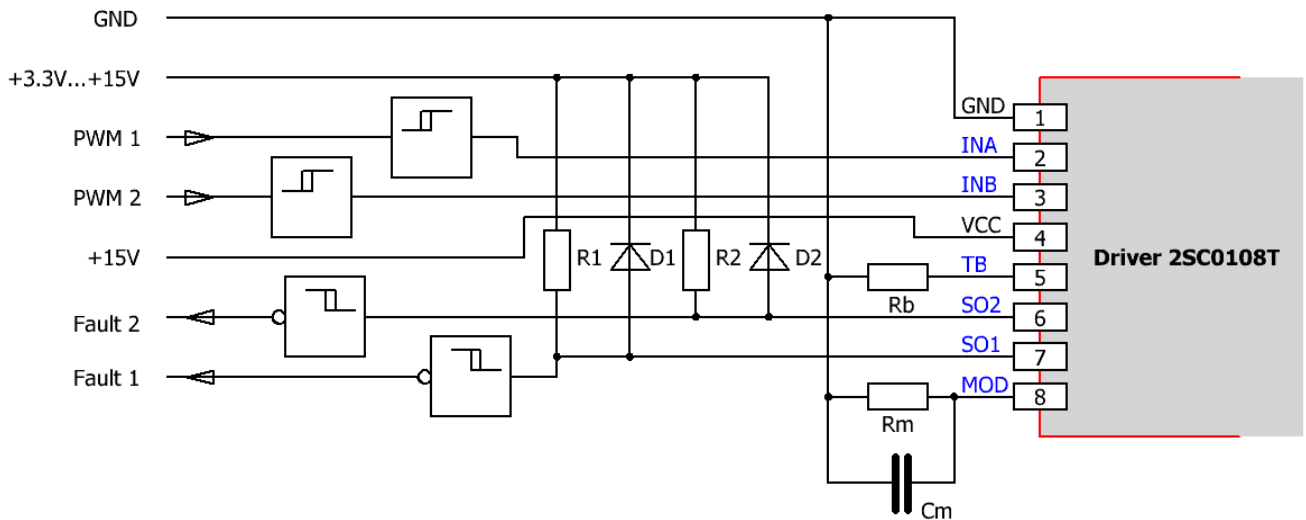

Fig. 5 Recommended user interface of 2SC0108T (primary side)

Description of Primary Side Interface

General

The primary side interface of the driver 2SC0108T is very simple and easy to use.

The driver primary side is equipped with an 8-pin interface connector with the following terminals:

- 1 x power-supply terminal
- 2 x drive signal inputs
- 2 x status outputs (fault returns)
- 1 x mode selection input (half-bridge mode / direct mode)
- 1 x input to set the blocking time

All inputs and outputs are ESD-protected. Moreover, all digital inputs have Schmitt-trigger characteristics.

VCC terminal

The driver has one VCC terminal on the interface connector. It supplies the primary side electronics as well as the DC-DC converter to supply the secondary sides with 15V.

The driver limits the inrush current at startup and no external current limitation of the voltage source for VCC is needed.

Preliminary Description & Application Manual

MOD (mode selection)

The MOD input allows the operating mode to be selected with a resistor connected to GND.

Direct mode

If the MOD input is connected to GND, direct mode is selected. In this mode, there is no interdependence between the two channels. Input INA directly influences channel 1 while INB influences channel 2. High level at an input (INA or INB) always results in turn-on of the corresponding IGBT. In a half-bridge topology, this mode should be selected only when the dead times are generated by the control circuitry so that each IGBT receives its own drive signal.

Caution: Synchronous or overlapping timing of both switches of a half-bridge basically shorts the DC-link.

Half-bridge mode

If the MOD input is connected to GND with a resistor $71k < R_m < 181k$, half-bridge mode is selected. In this mode, the inputs INA and INB have the following functions: INA is the drive signal input while INB acts as the enable input (see Fig. 6). It is recommended to place a capacitor $C_m = 22nF$ in parallel to R_m in order to reduce the deviation between the dead times at the rising and falling edges of INA respectively.

When input INB is low level, both channels are blocked. If it goes high, both channels are enabled and follow the signal on the input INA. At the transition of INA from low to high, channel 2 turns off immediately and channel 1 turns on after a dead time T_d .

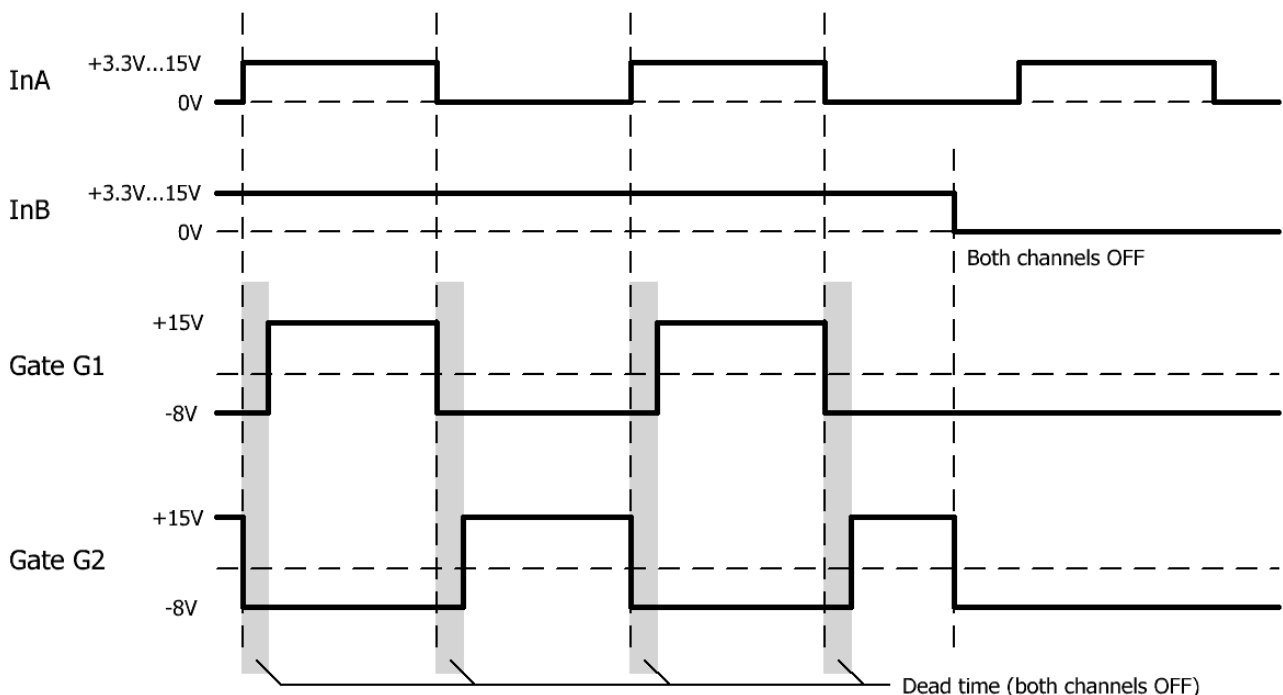

Fig. 6 Signals in half-bridge mode

The value of the dead time T_d is determined by the value of the resistor R_m according to the following formula (typical value):

$$R_m [k\Omega] = 33 \cdot T_d [\mu s] + 56.4 \quad \text{with } 0.5\mu s < T_d < 3.8\mu s \text{ and } 73k\Omega < R_m < 182k\Omega$$

Preliminary Description & Application Manual

INA, INB (channel drive inputs, e.g. PWM)

INA and INB are basically drive inputs, but their function depends on the MOD input (see above). They safely recognize signals in the whole logic-level range between 3.3V and 15V. Both input terminals feature Schmitt-trigger characteristics (refer to the driver data sheet /3/). An input transition is triggered at any edge of an incoming signal at INA or INB.

SO1, SO2 (status outputs)

The outputs SOx have open-drain transistors. When no fault condition is detected, the outputs have high impedance. An internal current source of 500µA pulls the SOx outputs to a voltage of about 4V when leaved open. When a fault condition (primary side supply undervoltage, secondary side supply undervoltage, IGBT short-circuit or overcurrent) is detected, the corresponding status output SOx goes to low (connected to GND).

The diodes D₁ and D₂ must be Schottky diodes and must only be used when using 3.3V logic. For 5V...15V logic, they can be omitted.

The maximum SOx current in a fault condition must not exceed the value specified in the driver data sheet /3/.

Both SOx outputs can be connected together to provide a common fault signal (e.g. for one phase). However, it is recommended to evaluate the status signals individually to allow fast and precise fault diagnosis.

How the status information is processed

- a) A fault on the secondary side (detection of short-circuit of IGBT module or supply undervoltage) is transmitted to the corresponding SOx output immediately. The SOx output is automatically reset (returning to a high impedance state) after a blocking time T_b has elapsed (refer to "TB (input for adjusting the blocking time T_b)" for timing information).
- b) A supply undervoltage on the primary side is indicated to both SOx outputs at the same time. Both SOx outputs are automatically reset (returning to a high impedance state) when the undervoltage on the primary side disappears.

TB (input for adjusting the blocking time T_b)

The terminal TB allows the blocking time T_b to be set by connecting a resistor R_b to GND (see Fig. 5). The following equation calculates the value of R_b connected between pins TB and GND in order to program the desired blocking time T_b (typical value):

$$R_b [k\Omega] = 1.0 \cdot T_b [ms] + 51 \quad \text{with} \quad 20ms < T_b < 130ms \text{ and } 71k\Omega < R_b < 181k\Omega$$

The blocking time can also be set to a minimum of 9µs (typical) by selecting R_b=0Ω. The terminal TB must not be left floating.

Note: It is also possible to apply a stabilized voltage at TB. The following equation is used to calculate the voltage V_b between TB and GND in order to program the desired blocking time T_b (typical value):

$$V_b [V] = 0.02 \cdot T_b [ms] + 1.02 \quad \text{with} \quad 20ms < T_b < 130ms \text{ and } 1.42 < V_b < 3.62V$$

Preliminary Description & Application Manual

Recommended Interface Circuitry for the Secondary Side Connectors

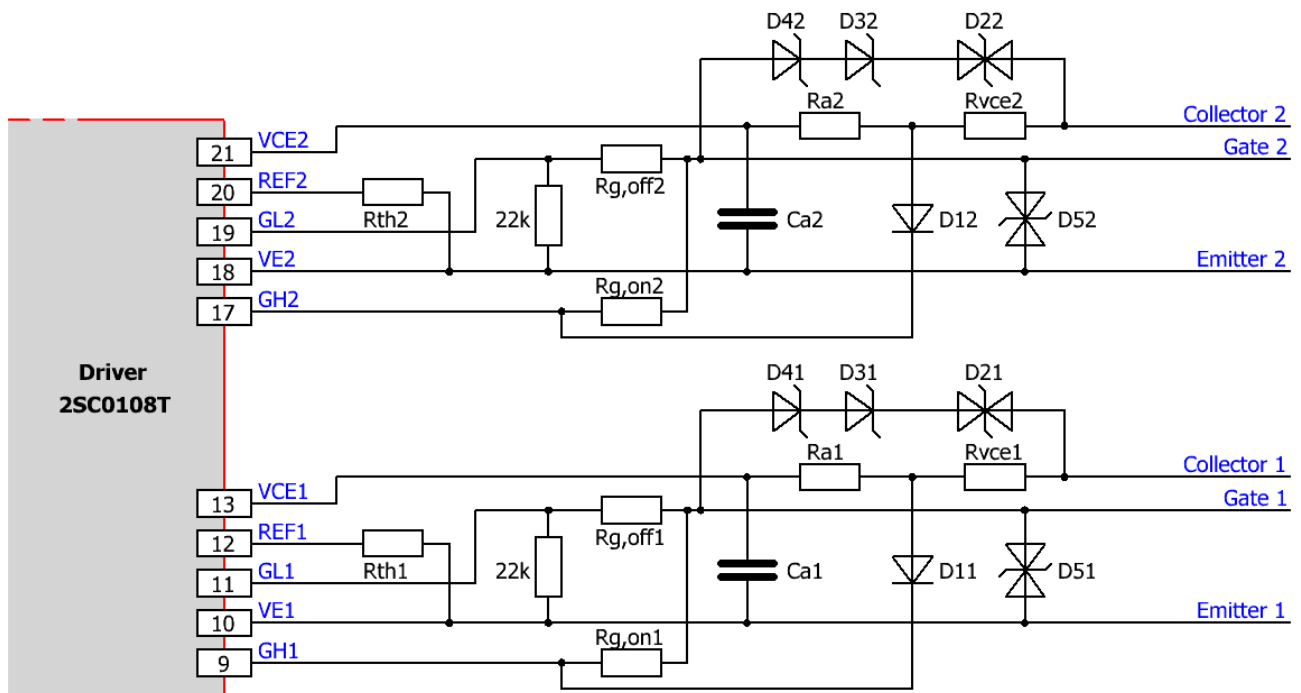

Fig. 7 Recommended user interface of 2SC0108T (secondary sides)

Description of Secondary Side Interfaces

General

Each driver’s secondary side (driver channel) is equipped with a 5-pin interface connector with the following terminals (x stands for the number of the drive channel 1 or 2):

- 1 x emitter terminal VEx
- 1 x reference terminal REFx for overcurrent or short-circuit protection
- 1 x collector sense terminal VCEx
- 1 x turn-on gate terminal GHx
- 1 x turn-off gate terminal GLx

All inputs and outputs are ESD-protected.

Emitter terminal (VEx)

The emitter terminal must be connected to the IGBT auxiliary emitter with the circuit shown in Fig. 7.

Preliminary Description & Application Manual

Reference terminals (REFx)

The reference terminal REFx allows the threshold to be set for short-circuit and/or overcurrent protection with a resistor placed between REFx and VEx. A constant current of 150µA is provided at pin REFx.

Collector sense (VCEx) with resistors

The collector sense of each channel of the 2SC0108T must be connected to the IGBT collector or MOSFET drain with the circuit shown in Figs. 7 or 8 in order to detect an IGBT or MOSFET overcurrent or short-circuit.

In an IGBT off-state, the driver's internal MOSFET connects pin VCEx to pin COMx. The capacitor C_{ax} is then precharged/discharged to the negative supply voltage, which is about -8V referred to VEx (red circle in Fig. 8 left). During this time, a current flows from the collector (blue circle in Fig. 8) via the resistor network and the diode BAS416 to GHx. The current is limited by the resistor chain.

It is recommended to dimension the resistor value of R_{vce_x} in order to obtain a current of about I_{Rvce_x}=0.6-1mA flowing through R_{vce_x} (e.g. 1.2-1.8MΩ for VDC-LINK=1200V). The current through R_{vce_x} must not exceed 1mA. A high-voltage resistor as well as series-connected resistors may be used. In any case, the minimum creepage distance required for the application must be considered.

The reference voltage is set by the resistor R_{thx}. It is calculated from the reference current (typically 150uA) and the reference resistance R_{thx} (green circle in Fig. 8)

$$V_{refx} = 150\mu A \cdot R_{thx}$$

Power Integrations recommends the use of R_{thx}=68kΩ. In this case the driver will safely protect the IGBT against short-circuit, but not necessarily against overcurrent. Overcurrent protection has a lower timing priority and is recommended to be realized within the host controller. Lower resistance values make the system more sensitive and do not provide any advantages in the case of desaturated IGBTs (short-circuit).

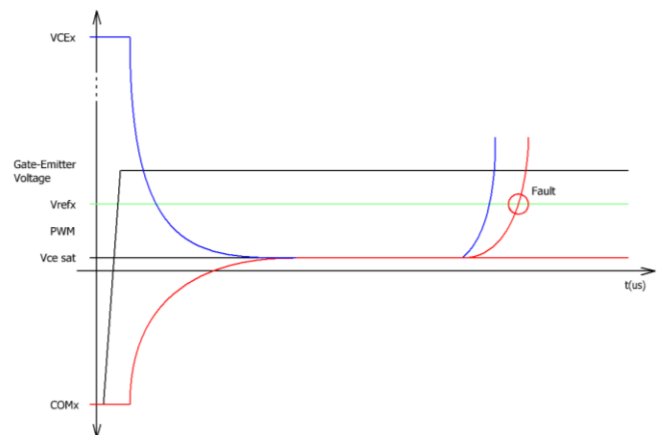
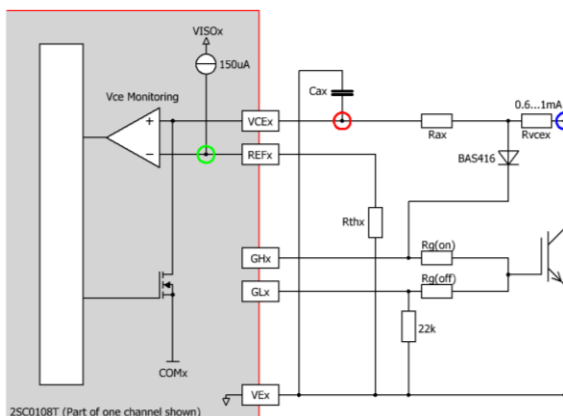

Fig. 8 V_{CE} desaturation protection with resistors

At IGBT turn-on and in the on-state, the driver's internal MOSFET turns off. While V_{CE} decreases (blue curve in Fig. 8), C_{ax} is charged from the COMx potential to the IGBT saturation voltage (red curve in Fig. 8). The time required to charge C_{ax} depends on the DC bus voltage, the value of the resistor R_{ax} and the value of the capacitor C_{ax}. For 1200V and 1700V IGBTs it is recommended to set R_{ax}=120kΩ. For 600V IGBTs the recommended value is R_{ax}=62kΩ.

During the response time, the V_{CE} monitoring circuit is inactive. The response time is the time that elapses after turn-on of the power semiconductor until the collector voltage is measured. It corresponds to the short-circuit duration.

Preliminary Description & Application Manual

The value of the response time capacitors C_{ax} can be determined from the following table in order to set the desired response time ($R_{v_{cex}}=1.8M\Omega$, $R_{ax}=120k\Omega$, DC-link voltage $V_{DC-LINK}>550V$):

C_{ax} [pF]	R_{thx} [k Ω]/ V_{thx} [V]	Response time [μ s]
0	43 / 6.45	1.2
15	43 / 6.45	3.2
22	43 / 6.45	4.2
33	43 / 6.45	5.8
47	43 / 6.45	7.8
0	68 / 10.2	1.5
15	68 / 10.2	4.9
22	68 / 10.2	6.5
33	68 / 10.2	8.9
47	68 / 10.2	12.2

Table 1 Typical response time as a function of the capacitance C_{ax} and the resistance R_{thx}

As the parasitic capacitances on the host PCB may influence the response time, it is recommended to measure it in the final design. It is important to define a response time which is shorter than the maximum permitted short-circuit duration of the power semiconductor used.

Note that the response time increases at DC-link voltage values lower than 550V ($R_{ax}=120k\Omega$) and/or higher threshold voltage values V_{thx} . The response time will decrease at lower threshold voltage values.

The diode D_{1x} in Fig. 7 must have a very low leakage current and a blocking voltage $>40V$ (e.g. BAS416). Schottky diodes must be explicitly avoided.

The components C_{ax} , R_{ax} , R_{thx} and D_{1x} must be placed as close as possible to the driver. A large collector-emitter loop must also be avoided.

When a short-circuit/overcurrent fault is detected, the driver switches off the corresponding power semiconductor. The fault status is immediately transferred to the corresponding SOx output of the affected channel. The power semiconductor is kept in the off-state (non-conducting) and the fault is shown at pin SOx as long as the blocking time T_b is active.

The blocking time T_b is applied independently to each channel. T_b starts as soon as a fault has been detected.

Desaturation protection with sense diodes

2SC0108T also provides desaturation protection with high-voltage diodes as shown in Fig. 9. However, the use of high-voltage diodes has some disadvantages compared to the use of resistors:

- Common-mode current relating to the rate of change dv_{ce}/dt of the collector-emitter voltage: High-voltage diodes have large junction capacitances C_j . These capacitances in combination with the dv_{ce}/dt generate a common-mode current I_{com} flowing in and out of the measurement circuit.

$$I_{com} = C_j \cdot \frac{dv_{ce}}{dt}$$

- Price: High-voltage diodes are more expensive than standard 0805/150V or 1206/200V SMD resistors.
- Availability: Standard thick-film resistors are comparatively easier to source on the market.

Preliminary Description & Application Manual

- Limited ruggedness: The reaction time does not increase at lower V_{CE} levels. Consequently, false triggering may occur at higher IGBT temperatures, higher collector currents, resonant switching or phase-shift PWM, particularly when the reference voltage V_{thx} is set below about 10V. The upper limit of the reference voltage is restricted to about 10V, which may lead to limited IGBT utilization: the collector current may be limited to values smaller than twice the nominal current, or the short-circuit withstand capability may be reduced.

During the IGBT off-state, D_{4x} (and R_{ax}) sets the V_{CEx} pin to $COMx$ potential, thereby precharging/discharging the capacitor C_{ax} to the negative supply voltage, which is about -8V referred to V_{Ex} . At IGBT turn-on, the capacitor C_{ax} is charged via R_{ax} . When the IGBT collector-emitter voltage drops below that limit, the voltage of C_{ax} is limited via the high-voltage diodes D_{1x} and D_{2x} . The voltage across C_{ax} can be calculated by:

$$V_{C_{ax}} = V_{CEsat} + V_{F(D1x)} + V_{F(D2x)} + \left(330\Omega \cdot \frac{15V - V_{CEsat} - V_{F(D1x)} - V_{F(D2x)}}{R_{ax} + 330\Omega} \right)$$

The reference voltage V_{refx} must be higher than V_{cax} . The reference voltage is set up by the resistor R_{thx} . The reference voltage is calculated via the reference current (typically 150uA) and the reference resistance R_{thx} :

$$V_{refx} = 150\mu A \cdot R_{thx}$$

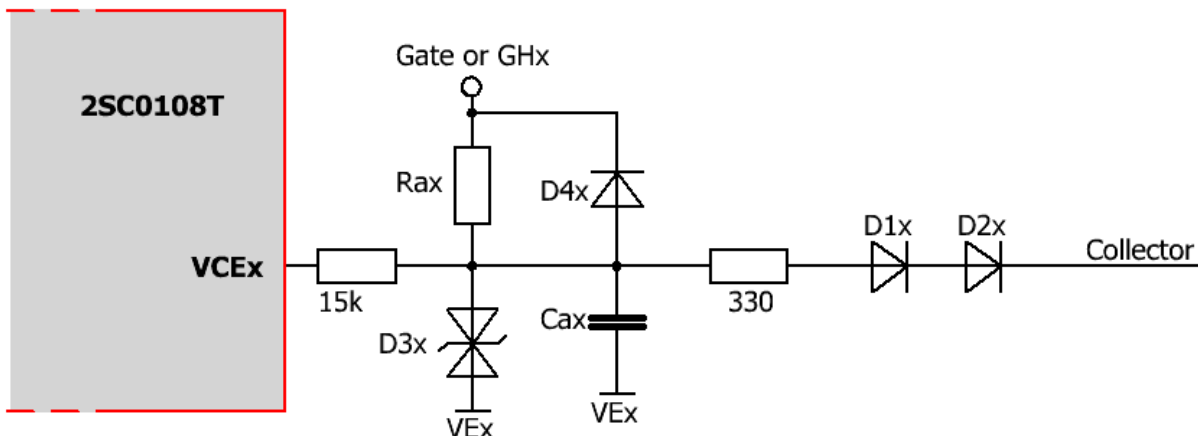

Fig. 9 Recommended circuit for desaturation protection with sense diodes (one channel shown)

The value of the resistance R_{ax} can be calculated with the following equation in order to program the desired response time T_{ax} at turn-on:

$$R_{ax} [k\Omega] \approx \frac{1000 \cdot T_{ax} [\mu s]}{C_{ax} [pF] \cdot \ln\left(\frac{15V + |V_{GLx}|}{15V - V_{refx}}\right)} \quad \text{Eq. 6}$$

V_{GLx} is the absolute value of the turn-off voltage at the driver output. It depends on the driver load and can be found in the driver data sheet /3/.

Recommended components $D_{1x}/D_{2x}/D_{3x}/D_{4x}$ and values for R_{ax} and C_{ax} are:

- High-voltage diodes D_{1x}/D_{2x} : 2x 1N4007 for 1200V IGBT
3x 1N4007 for 1700V IGBT
- D_{3x} : Transient voltage suppressor of the voltage class 12V...15V with small junction capacitance as CDDFN2-12C from Bourns.
- D_{4x} : High-speed diode as BAS316. Schottky diodes must be avoided.
- $R_{ax} = 24k\Omega \dots 62k\Omega$
- $C_{ax} = 100pF \dots 560pF$

Preliminary Description & Application Manual

Note that C_{ax} must include the parasitic capacitance of the transient voltage suppressor D_{3x} and the PCB.

Note also that the instantaneous V_{CE} threshold voltage is determined by the voltage at pin REFx (150 μ A through R_{thx}) minus the voltage across the 330 Ω resistor as well as the forward voltages across D_{1x} and D_{2x} .

The minimum off-state duration should not be shorter than about 1 μ s in order not to significantly reduce the response time for the next turn-on pulse.

Example: A resistor of $R_{ax} \approx 46k\Omega$ must be used to define a response time of 6 μ s with $C_{ax} = 150pF$, $R_{thx} = 33k\Omega$ and $V_{GLx} = 9V$.

Disabling the $V_{CE,sat}$ detection

To disable the $V_{CE,sat}$ measurement of 2SC0108T, a resistor with a minimum value of 33k Ω must be placed between VCEx and VEx according to Fig. 10.

The reference resistor R_{thx} may be chosen between 33k Ω and infinity, i.e. the REFx pin may be left open.

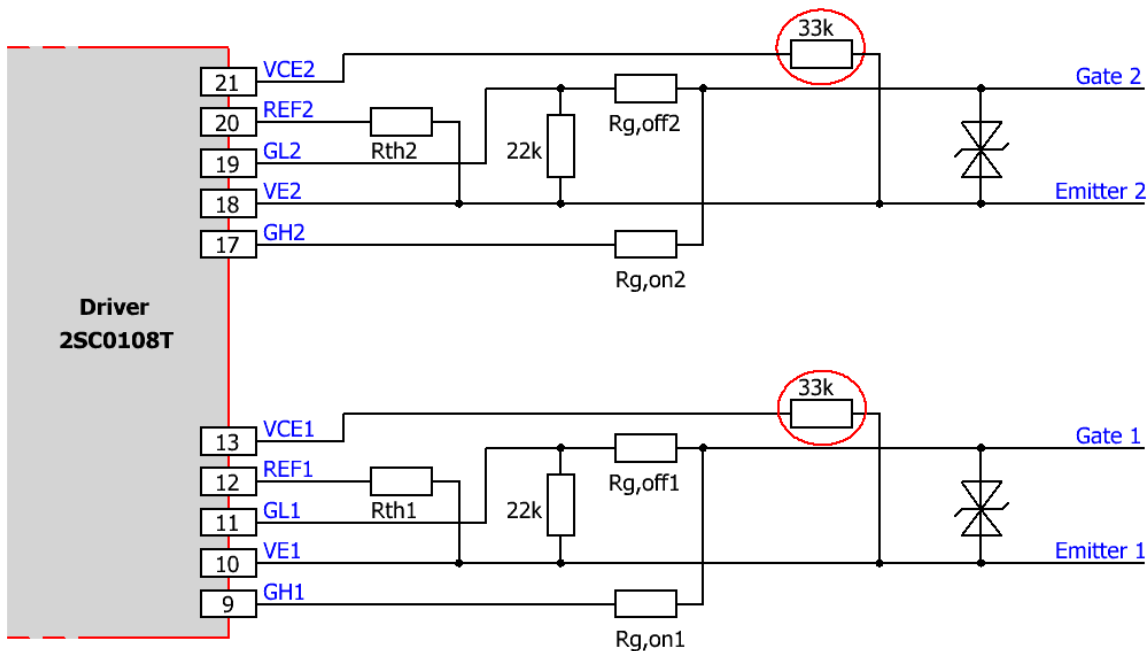

Fig. 10 Disabling the $V_{CE,sat}$ detection

Gate turn-on (GHx) and turn-off (GLx) terminals

These terminals allow the turn-on (GHx) and turn-off (GLx) gate resistors to be connected to the gate of the power semiconductor. The GHx and GLx pins are available as separated terminals in order to set the turn-on and turn-off resistors independently without the use of an additional diode. Please refer to the driver data sheet /3/ for the limit values of the gate resistors used.

A resistor between GLx and VEx of 22k (higher values are also possible) may be used in order to provide a low-impedance path from the IGBT gate to the emitter even if the driver is not supplied with power. Lower resistance values are not allowed.

A transient voltage suppressor device (D_{5x}) may be used between gate and emitter (e.g. SMBJ13CA) if the gate-emitter voltage becomes too high in the IGBT short-circuit condition, thus leading to excessive short-circuit currents.

Preliminary Description & Application Manual

Note however that it is not advisable to operate the power semiconductors within a half-bridge with a driver in the event of a low supply voltage. Otherwise, a high rate of increase of V_{CE} may cause partial turn-on of these IGBTs.

Active clamping

Active clamping is a technique designed to partially turn on the power semiconductor as soon as the collector-emitter (drain-source) voltage exceeds a predefined threshold. The power semiconductor is then kept in linear operation.

Basic active clamping topologies implement a single feedback path from the IGBT's collector through transient voltage suppressor devices (TVS) to the IGBT gate. The 2SC0108T supports basic active clamping.

It is recommended to use the circuit shown in Fig. 7. The following parameters must be adapted to the application:

- TVS D_{2x} , D_{3x} and D_{4x} . It is recommended to use:
 - Six 80V TVS with 600V IGBTs with DC-link voltages up to 430V. Good clamping results can be obtained with five unidirectional TVS P6SMBJ70A and one bidirectional TVS P6SMBJ70CA from Semikron or with five unidirectional TVS SMBJ70A-E3 and one bidirectional TVS SMBJ70CA-E3 from Vishay.
 - Six 150V TVS with 1200V IGBTs with DC-link voltages up to 800V. Good clamping results can be obtained with five unidirectional TVS SMBJ130A-E3 and one bidirectional TVS SMBJ130CA-E3 from Vishay or five unidirectional TVS SMBJ130A-TR from ST and one bidirectional TVS P6SMBJ130CA from Diotec.
 - Six 220V TVS with 1700V IGBTs with DC-link voltages up to 1200V. Good clamping results can be obtained with five unidirectional TVS P6SMB220A and one bidirectional TVS P6SMB220CA from Diotec or five unidirectional TVS SMBJ188A-E3 and one bidirectional TVS SMBJ188CA-E3 from Vishay.

At least one bidirectional TVS (D_{2x}) per channel must be used in order to avoid negative current flowing through the TVS chain during turn-on of the antiparallel diode of the IGBT module due to its forward recovery behavior. Such a current could, depending on the application, lead to undervoltage of the driver secondary voltage VISO_x to VEx (15V).

Note that it is possible to modify the number of TVS in a chain. The active clamping efficiency can be improved by increasing the number of TVS used in a chain if the total threshold voltage remains at the same value. Note also that the active clamping efficiency is highly dependent on the type of TVS used (e.g. manufacturer).

Note that the active clamping performance can be improved by increasing the value of the turn-off gate resistors $R_{g,offx}$.

If active clamping is not used, the TVS D_{2x} , D_{3x} and D_{4x} can be omitted.

Soft Shut Down (SSD)

The SSD function is implemented and cannot be deactivated on the following SCALE-2+ types of 2SC0108T drivers: 2SC0108T2F1-17, 2SC0108T2G0-17 and 2SC0108T2H0-17 (refer to the driver data sheet /3/). All other driver's types do not feature the SSD function.

The SSD function reduces the turn-off di/dt to limit the Vce overvoltage as soon as a short-circuit condition is detected. An excessive turn-off overvoltage is therefore avoided and the power semiconductor is turned off within its safe operating area.

Preliminary Description & Application Manual

The SSD function is realized with a closed loop scheme which is activated as soon as an IGBT short circuit is detected. The driver then measures the gate-emitter voltage and adjusts it according to the three following phases:

- In a first step, the gate-emitter voltage is decreased to a defined level controlled with the closed loop feedback.
- The defined level of the gate-emitter voltage is held at the given level to ramp down the collector current smoothly (e.g. with lower di/dt) until the gate charge profile of the power semiconductor has reached the end of the Miller plateau. The end of the Miller plateau is detected by evaluating the gate current.
- The gate-emitter voltage is then reduced to its end value, following a given reference value.

The SSD function is only active when a short-circuit condition has been detected and not under normal operating conditions (e.g. at nominal current or under over-current conditions). It may therefore be necessary to increase the turn-off gate resistance or to take appropriate measures (e.g. lower DC-link stray inductance) to avoid excessive turn-off overvoltages under normal operating conditions.

Note that the SSD function uses a closed-loop scheme. It may therefore not necessarily perform better with a higher value of the turn-off gate resistor.

Even if the SSD function uses a closed-loop regulation scheme, it has performance limitations. Excessive DC-link stray inductance values may therefore lead to excessive turn-off overvoltages in the short-circuit condition. It is therefore necessary to characterize the short-circuit behavior of the IGBT under all application-relevant conditions, especially over the full IGBT and driver ambient temperature range, and to consider sufficient safety margins of the V_{CE} peak voltage to achieve a rugged design.

If the V_{CE} peak voltage is excessively high and cannot be lowered by other means, Power Integrations additionally recommends using basic active clamping according to the paragraph "Active clamping".

How Do 2SC0108T SCALE-2+ Drivers Work in Detail?

Power supply and electrical isolation

The driver is equipped with a DC/DC converter to provide an electrically insulated power supply to the gate driver circuitry. All transformers (DC/DC and signal transformers) feature safe isolation to EN 50178, protection class II between primary side and either secondary side.

Note that the driver requires a stabilized supply voltage.

Power-supply monitoring

The driver's primary side as well as both secondary-side driver channels are equipped with a local undervoltage monitoring circuit.

In the event of a primary-side supply undervoltage, the power semiconductors are driven with a negative gate voltage to keep them in the off-state (the driver is blocked) and the fault is transmitted to both outputs SO1 and SO2 until the fault disappears.

In case of a secondary-side supply undervoltage, the corresponding power semiconductor is driven with a negative gate voltage to keep it in the off-state (the channel is blocked) and a fault condition is transmitted to the corresponding SOx output. The SOx output is automatically reset (returning to a high impedance state) after the blocking time.

Preliminary Description & Application Manual

Within a half-bridge, it is advised not to operate the IGBTs with an IGBT driver in the event of a low supply voltage. Otherwise, a high rate of increase of V_{CE} may cause partial turn-on of these IGBTs.

Parallel connection of 2SC0108T

If parallel connection of 2SC0108T drivers is required, please refer to the application note AN-0904 /5/ on www.power.com/igbt-driver/go/app-note.

3-level or multilevel topologies

If 2SC0108T drivers are to be used in 3-level or multilevel topologies, please refer to the application note AN-0901 /6/ on www.power.com/igbt-driver/go/app-note.

Additional application support for 2SC0108T

For additional application support using 2SC0108T drivers, please refer to the application note AN-1101 /4/ on www.power.com/igbt-driver/go/app-note.

Electrical Ratings for UL recognized types

The following ratings apply for the UL recognized product versions according to the UL definitions:

Power/Channel	Gate Current	Control Circuit (Input/Output)	System Voltage
1.2W	8A	15Vdc	730Vac/dc

Bibliography

- /1/ Paper: Smart Power Chip Tuning, Bodo's Power Systems, May 2007
- /2/ "Description and Application Manual for SCALE™ Drivers", Power Integrations
- /3/ Data sheet SCALE™-2+ driver core 2SC0108T, Power Integrations
- /4/ Application note AN-1101: Application with SCALE™-2 and SCALE™-2+ Gate Driver Cores, Power Integrations
- /5/ Application note AN-0904: Direct Paralleling of SCALE™-2 Gate Driver Cores, Power Integrations
- /6/ Application note AN-0901: Methodology for Controlling Multi-Level Converter Topologies with SCALE™-2 IGBT Drivers, Power Integrations

Note: The Application Notes are available on the Internet at www.power.com/igbt-driver/go/app-note and the papers at www.power.com/igbt-driver/go/papers.

Preliminary Description & Application Manual

The Information Source: SCALE-2 and SCALE-2+ Driver Data Sheets

Power Integrations offers the widest selection of gate drivers for power MOSFETs and IGBTs for almost any application requirements. The largest website on gate-drive circuitry anywhere contains all data sheets, application notes and manuals, technical information and support sections: www.power.com.

Quite Special: Customized SCALE-2 and SCALE-2+ Drivers

If you need an IGBT driver that is not included in the delivery range, please don't hesitate to contact Power Integrations or your Power Integrations sales partner.

Power Integrations has more than 30 years experience in the development and manufacture of intelligent gate drivers for power MOSFETs and IGBTs and has already implemented a large number of customized solutions.

Technical Support

Power Integrations provides expert help with your questions and problems:

www.power.com/igbt-driver/go/support

Quality

The obligation to high quality is one of the central features laid down in the mission statement of Power Integrations Switzerland GmbH. Our quality management system assures state-of-the-art processes throughout all functions of the company, certified by ISO9001 standards.

Legal Disclaimer

The statements, technical information and recommendations contained herein are believed to be accurate as of the date hereof. All parameters, numbers, values and other technical data included in the technical information were calculated and determined to our best knowledge in accordance with the relevant technical norms (if any). They may base on assumptions or operational conditions that do not necessarily apply in general. We exclude any representation or warranty, express or implied, in relation to the accuracy or completeness of the statements, technical information and recommendations contained herein. No responsibility is accepted for the accuracy or sufficiency of any of the statements, technical information, recommendations or opinions communicated and any liability for any direct, indirect or consequential loss or damage suffered by any person arising therefrom is expressly disclaimed.

Preliminary Description & Application Manual

Ordering Information

Our international terms and conditions of sale apply.

Type Designation	Description
2SC0108T2F1-17	SCALE-2+ driver core (Lead free, -40°C...85°C, connector pin length: 5.84mm, increased EMI capability, SSD)
2SC0108T2F1C-17	SCALE-2+ driver core (Lead free, -40°C...85°C, connector pin length: 5.84mm, increased EMI capability, SSD, conformal coating)
2SC0108T2G0-17	SCALE-2+ driver core (Lead free, -40°C...85°C, connector pin length: 3.1mm, increased EMI capability, SSD)
2SC0108T2G0C-17	SCALE-2+ driver core (Lead free, -40°C...85°C, connector pin length: 3.1mm, increased EMI capability, SSD, conformal coating)
2SC0108T2H0-17	SCALE-2+ driver core (Lead free, -40°C...85°C, connector pin length: 2.54mm, increased EMI capability, SSD)
2SC0108T2H0C-17	SCALE-2+ driver core (Lead free, -40°C...85°C, connector pin length: 2.54mm, increased EMI capability, SSD, conformal coating)

Product home page: www.power.com/igbt-driver/go/2SC0108T

Refer to www.power.com/igbt-driver/go/nomenclature for information on driver nomenclature

Information about Other Products

For other driver cores:

Direct link: www.power.com/igbt-driver/go/cores

For other drivers, product documentation, evaluation systems and application support:

Please click onto: www.power.com

Preliminary Description & Application Manual

Power Integrations Sales Offices

WORLD HEADQUARTERS

5245 Hellyer Avenue
San Jose, CA 95138 USA
Tel: +1-408-414-9200
Fax: +1-408-414-9765
Email: usasales@power.com

AMERICAS WEST

5245 Hellyer Avenue
San Jose, CA 95138 USA
Tel: +1-408-414-8778
Fax: +1-408-414-3760
Email: usasales@power.com

GERMANY (AC-DC/LED Sales)

Lindwurmstrasse 114
80337 München, Germany
Tel: +49-89-5527-39100
Fax: +49-89-1228-5374
Email: eurosales@power.com

INDIA (Mumbai)

Unit: 106-107, Sagar Tech Plaza-B
Sakinaka, Andheri Kurla Road
Mumbai, Maharashtra 400072 India
Tel 1: +91-22-4003-3700
Tel 2: +91-22-4003-3600
Email: indiasales@power.com

JAPAN

Kosei Dai-3 Bldg.
2-12-11, Shin-Yokohama, Kohoku-ku
Yokohama-shi, Kanagawa
Japan 222-0033
Tel: +81-45-471-1021
Fax: +81-45-471-3717
Email: japansales@power.com

TAIWAN

5F, No. 318, Nei Hu Rd., Sec. 1
Nei Hu Dist.
Taipei, 114 Taiwan
Tel: +886-2-2659-4570
Fax: +886-2-2659-4550
Email: taiwansales@power.com

AMERICAS EAST

7360 McGinnis Ferry Road
Suite 225
Suwanee, GA 30024 USA
Tel: +1-678-957-0724
Fax: +1-678-957-0784
Email: usasales@power.com

CHINA (Shanghai)

Room 2410, Charity Plaza
No. 88 North Caoxi Road
Shanghai, 200030 China
Tel: +86-21-6354-6323
Fax: +86-21-6354-6325
Email: chinasales@power.com

GERMANY (Gate Driver Sales)

HellwegForum 1
59469 Ense, Germany
Tel: +49-2938-64-39990
Email: igbt-driver.sales@power.com

INDIA (New Dehli)

#45, Top Floor
Okhla Industrial Area, Phase - III
New Dehli, 110020 India
Tel 1: +91-11-4055-2351
Tel 2: +91-11-4055-2353
Email: indiasales@power.com

KOREA

RM602, 6FL, 22
Teheran-ro 87-gil, Gangnam-gu
Seoul, 06164 Korea
Tel: +82-2-2016-6610
Fax: +82-2-2016-6630
Email: koreasales@power.com

UNITED KINGDOM

Bulding 5, Suite 21
The Westbrook Centre
Milton Road
Cambridge, CB4 1YG United Kingdom
Tel: +44-7823-557-484
Email: eurosales@power.com

AMERICAS CENTRAL

333 Sheridan Road
Winnetka, IL 60093 USA
Tel: +1-847-721-6293
Email: usasales@power.com

CHINA (Shenzhen)

17/F, Hivac Building, No 2
Keji South 8th Road, Nanshan District
Shenzhen, 518057 China
Tel: +86-755-8672-8689
Fax: +86-755-8672-8690
Email: chinasales@power.com

INDIA (Bangalore)

#1, 14th Main Road
Vasanthangar
Bangalore, 560052 India
Tel 1: +91-80-4113-8020
Tel 2: +91-80-4113-8028
Fax: +91-80-4113-8023
Email: indiasales@power.com

ITALY

Via Milanese 20
20099 Sesto San Giovanni (MI), Italy
Tel: +39-02-4550-8708
Email: eurosales@power.com

SINGAPORE

51 Newton Road
#19-01/05 Goldhill Plaza
Singapore, 308900
Tel 1: +65-6358-2160
Tel 2: +65-6358-4480
Fax: +65-6358-2015
Email: singaporesales@power.com