

# CableComp™ Cable Drop Compensation

- Another low cost circuit using R1/D1 CC circuit of the previous slide plus 'cable drop' voltage compensation
  - As the output current ( $I_1$ ) increases and the voltage across R1 increases, Q1 is turned on and gradually increases the voltage dropped across R3 forcing the output voltage regulation threshold higher
  - Saves up to \$0.05 compared to typical TL431 circuits used for this purpose

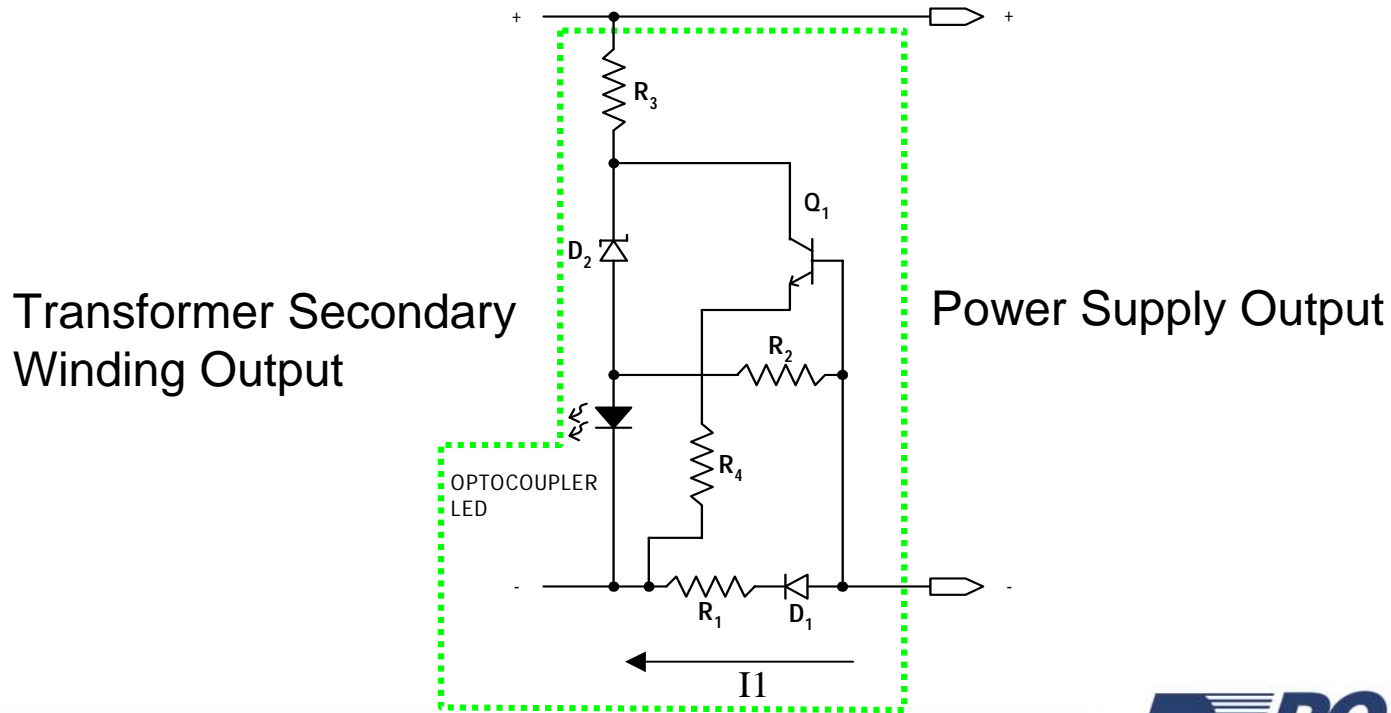

# CableComp™ Cable Drop Compensation

- Another 2 versions with 'cable drop' voltage compensation are shown below

