

DI-80 Design Idea

LinkSwitch-TN[®]

0.6 W Non-Isolated Utility Meter Power Supply

Application	Device	Power Output	Input Voltage	Output Voltage	Topology
Utility Meter	LNK302PN	0.6 W	85 – 265 VAC, 47-63 Hz	12 V, 50 mA	Buck

Design Highlights

- Universal AC input voltage range
- Meets EN62053-21:2003 (<1 W real and <5 VA apparent input power at 265 VAC)
- Long holdup time (140/580 ms at 115/230 VAC)
- High efficiency (>60 % at 265 VAC)
- Very low no-load consumption (0.15 W at 265 VAC)
- EMI compliant (EN55022B, CISPR-22B)
- Extended line surge withstand with integrated 700 V MOSFET
- Small size and light weight
- Scalable output power using larger LinkSwitch-TN family members

Operation

Using the buck topology, the circuit shown in Figure 1 generates a non-isolated 12 V, 50 mA output. Typical uses include utility meter and industrial and motor control applications.

The AC input is rectified and filtered by D1, D2, C1, C2, RF1, R1, and R2. Two rectifiers improve both line surge withstand (2 kV) and conducted EMI. Resistor RF1 should be a fusible flameproof type, whereas R1 and R2 can be flameproof only. In meter applications, capacitors C1 and C2 are sized for the required holdup time to write the meter reading to non-volatile memory after a power outage.

LinkSwitch-TN uses on/off control to regulate the output voltage. When the current into the FEEDBACK (FB) pin exceeds 49 μ A, MOSFET switching is disabled for the next switching cycle. The 49 μ A threshold is specified at an FB pin voltage of 1.65 V (\pm 7% over the entire operating temperature range), allowing it to be used as a reference.

The power processing stage is formed by the LinkSwitch-TN, freewheeling diode D3, output choke L1, and the output capacitor C5. To a first order, the forward voltage drops of D3 and D4 are equal. Therefore, the voltage across C4 tracks the output voltage. The voltage across C4 is sensed and regulated via the resistor divider R4 and R3 connected to the LNK302PN FB pin. The values of R3 and R4 are selected such that, at the desired output voltage, the voltage at the FB pin is 1.65 V. Resistor R5 establishes a small 3.6 mA pre-load and is only necessary for applications where regulation to zero load is required.

The value of L1 is selected according to the LinkSwitch-TN Design Guide (AN-37) or the PIXIs design spreadsheet (part of PI Expert™ power supply design software). Both are available at www.powerint.com.

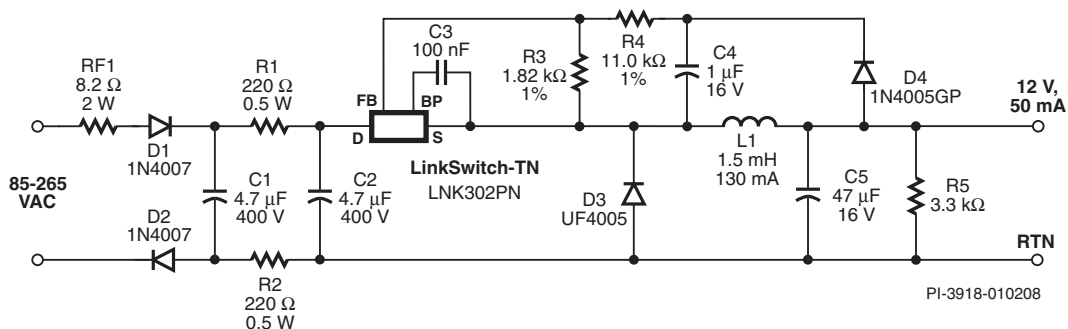

Figure 1. LinkSwitch-TN 0.6 W, 12 V, Universal Input Power Supply Using a Non-Isolated Buck Topology.

Key Design Points

- The output is not safety isolated from the input.
- The circuit shown in Figure 1 has a total output voltage tolerance of $\pm 10\%$ ($-20\text{ }^{\circ}\text{C}$ to $+85\text{ }^{\circ}\text{C}$ ambient temperature).
- To prevent noise coupling and to decrease EMI, place the input filter components physically away from the source node of the LinkSwitch-TN and L1 inductor.
- The DC input filter capacitors C1 and C2 can be placed as a barrier between the AC input and LNK302PN and L1. Their size depends on the minimum operating input voltage and required holdup time.
- Select ESR of output filter capacitor C5 based on the output voltage noise requirement.

- Diode D3 should be an ultra-fast type. A reverse recovery time $t_{rr} \leq 75\text{ ns}$ should be used at an ambient temperature of $+70\text{ }^{\circ}\text{C}$ or below. If the ambient temperature is higher, then a diode with $t_{rr} \leq 35\text{ ns}$ should be used.
- Feedback diode D4 can be a low-cost slow diode such as 1N400X series, however it should be specified as a glass passivated type to guarantee a specified reverse recovery time.
- Pre-load R5 is only required for output regulation down to zero load.
- Use LNK304PN for up to 110 mA output current ($< 2\text{ W}$ true input power and $< 6\text{ VA}$ apparent input power at 265 VAC).
- Select output inductor L1 value and current rating accordingly.
- See LinkSwitch-TN Design Guide for in-depth information.

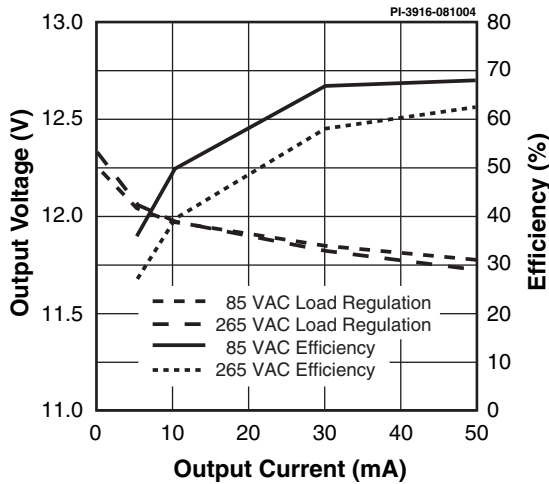

Figure 2. Output Regulation (left Y-axis) and Efficiency (right Y-axis) Over Load Current at 85 VAC and 265 VAC Input.

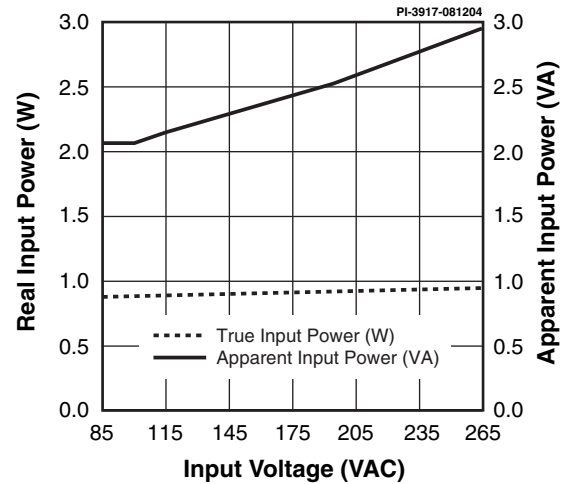

Figure 3. Real Input Power (left Y-axis) and Apparent Input Power (right Y-axis) AC Input Voltage at 50 mA Load Current (0.6 W Load).

Power Integrations
5245 Hellyer Avenue
San Jose, CA 95138, USA.
Main: +1 408-414-9200
Customer Service
Phone: +1-408-414-9665
Fax: +1-408-414-9765
Email: usasales@powerint.com

On the Web
www.powerint.com

Power Integrations reserves the right to make changes to its products at any time to improve reliability or manufacturability. Power Integrations does not assume any liability arising from the use of any device or circuit described herein. POWER INTEGRATIONS MAKES NO WARRANTY HEREIN AND SPECIFICALLY DISCLAIMS ALL WARRANTIES INCLUDING, WITHOUT LIMITATION, THE IMPLIED WARRANTIES OF MERCHANTABILITY, FITNESS FOR A PARTICULAR PURPOSE, AND NON-INFRINGEMENT OF THIRD PARTY RIGHTS. The products and applications illustrated herein (transformer construction and circuits external to the products) may be covered by one or more U.S. and foreign patents or potentially by pending U.S. and foreign patent applications assigned to Power Integrations. A complete list of Power Integrations' patents may be found at www.powerint.com. Power Integrations grants its customers a license under certain patent rights as set forth at <http://www.powerint.com/ip.htm>.

The PI logo, TOPSwitch, TinySwitch, LinkSwitch, DPA-Switch, PeakSwitch, EcoSmart, Clampless, E-Shield, Filterfuse, StackFET, PI Expert and PI FACTS are trademarks of Power Integrations, Inc. Other trademarks are property of their respective companies. ©2004, Power Integrations, Inc.