

DI-56 Design Idea

DPA-Switch®

19.2 W DC-DC Converter

Application	Device	Power Output	Input Voltage	Output Voltage	Topology
Telecom	DPA425R	19,2 W	36 – 75 VDC	+12 V	Flyback

Design Highlights

- Low cost 400 kHz flyback design
- ± 12 V outputs at $\pm 5\%$ accuracy
- Highly efficient diode rectification design – 80% at 48 V
- Low component count
- Accurate line OV and UV protection
- Thermal, short circuit and output overload protection
- No current sense components

Operation

DPA-Switch greatly simplifies the design compared to a discrete implementation. Resistor R1 programs the under/over voltages and linearly reduces the maximum duty cycle with input voltage to prevent core saturation during load transients. Resistor R3 programs the DPA-Switch current limit at 77% of nominal to minimize fault and overload power. Drain voltage clamping is provided by Zener diode VR1.

Output regulation is taken from the +12 V output. The -12 V output is magnetically coupled. Shared regulation of +12 V and -12 V may be used if better cross-regulation is required between the two outputs. Optional resistor R7, diode D3 and capacitor C16 implement a soft-finish network to slow the rise of the output voltage at start-up, preventing overshoot.

The bias winding provides operating power to the DPA-Switch. The regulation is fed back from the secondary through the opto-transistor of U2. The DPA-Switch will go into auto-restart in the event of optocoupler (U2) failure, or output short circuit. The optional resistor R5 and Zener diode VR2 provide a fail-safe output regulation path, limiting the instantaneous output over-voltage in the event of U2 failure.

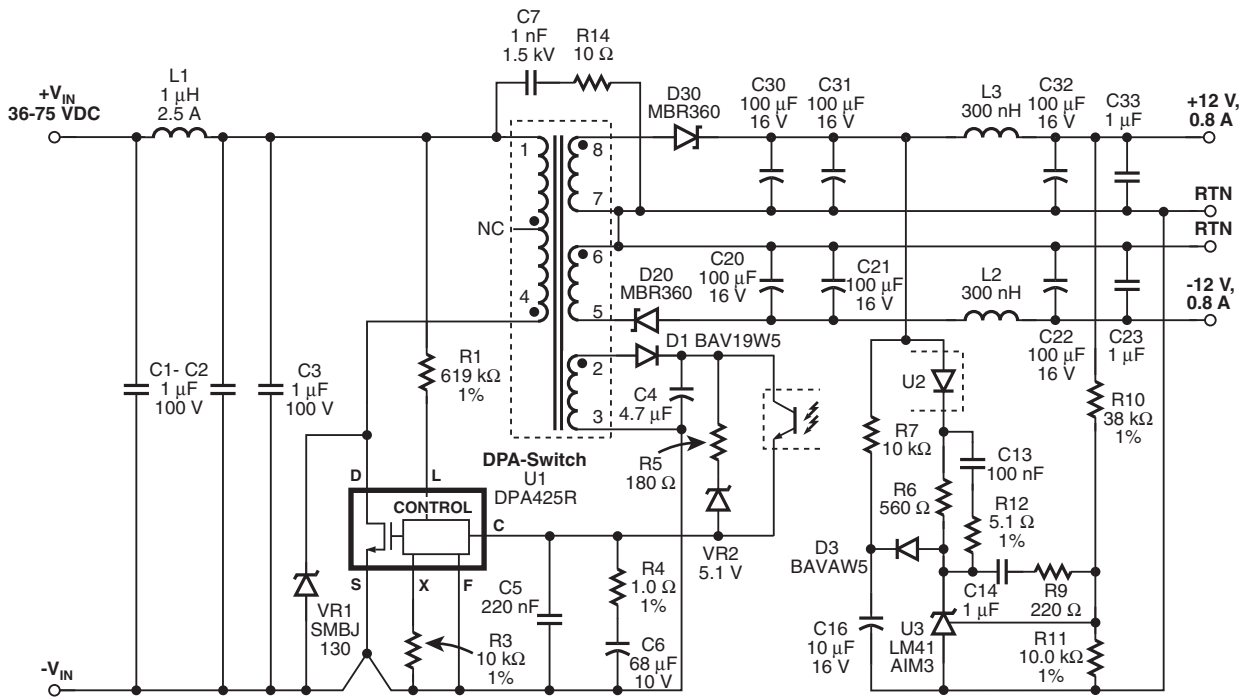

Figure 1. 19.2 W, +12 V, 0.8 A, DC-DC Converter.

PI-3649-081103

Key Design Points

- For the nominal under-voltage set point V_{UV} :
 $R1 = (V_{UV} - 2.35) / 50 \mu A$
 $V_{OV} = (R1 \times 135 \mu A) + 2.5 V$
- For highest efficiency designs: use continuous conduction mode operation designed at approximately 0.4 KRP; minimize turns in the transformer and at this (19 W) power level keep AC flux density (BM) <1500 Gauss; fully fill a single layer for each winding to minimize leakage inductance and maximize copper fill factor; if possible use Schottky rectifying diodes (D20 and D30) with a low-forward drop.
- The transformer primary is split in order to minimize leakage inductance and thus obtain better cross-regulation. Note: minimizing primary leakage inductance will improve output cross-regulation at load extremes.
- The -12 V output is not directly sensed as part of the regulation loop. Cross-regulation may be improved by adding a second sense resistor to work in conjunction with R10. Both resistors R10 and the second sense resistor would be changed to 76 k Ω each.
- Set resonant frequency of post-filter (L2, C22 or L3, C32) beyond crossover frequency (typically 5% to 10% of switching frequency).
- Good layout practices
 - For length of +12 V secondary current loop from transformer pin 8, diode D30 and capacitors C30, C31 and back to pin 7 of the transformer: ensure identical path length for C30 and C31 to guarantee they equally share the ripple current.
 - The same is also true for the layout of the -12 V output.
- Choosing a larger DPA-Switch will increase efficiency at low and medium input voltages.

Transformer Parameters

Core Material	EPCOS P/N: P 14 x 8 N87, ungapped
Bobbin	8-pin P 14 x 8 surface mount bobbin
Winding Details	Primary: 7T + 7T, 2 x 29 AWG Bias: 5T, 1 x 36 AWG +12 V: 5T, 2 x 29 AWG -12 V: 5T, 2 x 29 AWG
Winding Order (pin numbers)	Primary-1 (4-NC), -12 V (6-5), Bias (2-3), +12 V (8-7), Primary-2 (NC-1)
Primary Inductance	22 μH $\pm 25\%$ (at 400 kHz)
Primary Resonant Frequency	3.8 MHz (minimum)
Leakage Inductance	0.75 μH (maximum)

Table 1. Transformer Parameters. (AWG = American Wire Gauge, NC = No Connection)

Power Integrations
5245 Hellyer Avenue
San Jose, CA 95138, USA.
Main: +1 408-414-9200
Customer Service
Phone: +1-408-414-9665
Fax: +1-408-414-9765
Email: usasales@powerint.com

On the Web
www.powerint.com

Power Integrations reserves the right to make changes to its products at any time to improve reliability or manufacturability. Power Integrations does not assume any liability arising from the use of any device or circuit described herein. POWER INTEGRATIONS MAKES NO WARRANTY HEREIN AND SPECIFICALLY DISCLAIMS ALL WARRANTIES INCLUDING, WITHOUT LIMITATION, THE IMPLIED WARRANTIES OF MERCHANTABILITY, FITNESS FOR A PARTICULAR PURPOSE, AND NON-INFRINGEMENT OF THIRD PARTY RIGHTS. The products and applications illustrated herein (transformer construction and circuits external to the products) may be covered by one or more U.S. and foreign patents or potentially by pending U.S. and foreign patent applications assigned to Power Integrations. A complete list of Power Integrations' patents may be found at www.powerint.com. Power Integrations grants its customers a license under certain patent rights as set forth at <http://www.powerint.com/ip.htm>.

The PI logo, TOPSwitch, TinySwitch, LinkSwitch, DPA-Switch, PeakSwitch, EcoSmart, Clampless, E-Shield, Filterfuse, StackFET, PI Expert and PI FACTS are trademarks of Power Integrations, Inc. Other trademarks are property of their respective companies. ©2003, Power Integrations, Inc.