

# DI-197 Design Idea TOPSwitch®-HX

## 65 W Notebook Adapter

Application	Device	Power Output	Input Voltage	Output Voltage	Topology
Notebook Adapter	TOP258EN	65 W	90 – 265 VAC	19 V	Flyback

### Design Highlights

- Very compact, low parts-count design
  - Internal current limit reduction eliminates secondary-side current limit circuit
  - Primary side overvoltage protection (OVP) eliminates second optocoupler
- 700 V MOSFET reduces solution cost
  - Lower-cost (60 V, 20 A) Schottky output diode replaces 100 V, 40 A diode
  - 132 kHz operation reduces transformer size
  - Low MOSFET capacitance allows higher frequency operation without efficiency penalty
- Highly energy efficient
  - Very low no-load input power: <200 mW @ 265 VAC
  - High full-load efficiency: >87%
  - High average efficiency: >86%
- Excellent transient load response
- Hysteretic thermal overload protection
- Overload protection with automatic recovery
- Latching fault protection

### Operation

The schematic in Figure 1 depicts a notebook adapter power supply employing the Power Integrations® TOPSwitch®-HX

TOP258EN off-line switcher in a flyback configuration. This power supply operates from a universal input to provide a 19 V, 65 W output capable of operation in a sealed enclosure at an ambient temperature of up to 40 °C.

The TOP258EN (U1) has an integrated 700 V MOSFET and a multi-mode controller to regulate output by adjusting the MOSFET duty cycles, in response to current fed into the Control (C) pin.

The EcoSmart® function in U1 provides constant efficiency over an entire load range. Using a proprietary multi-cycle-modulation (MCM) function eliminates the need for special operating modes triggered at specific loads and operating conditions, optimizing performance for existing and emerging energy-efficiency regulations.

Fuse F1 provides protection to the rest of the circuit from catastrophic failures. Common-mode inductors L3 and L4 provide line filtering. X-capacitor C1 provides differential filtering, and resistors R1 and R2 provide safety from shock upon AC removal. Bridge rectifier D1 rectifies the AC input, and bulk capacitor C2 filters the DC. Y-capacitor C11, connected between the transformer (T1) primary and secondary side provides common-mode filtering.

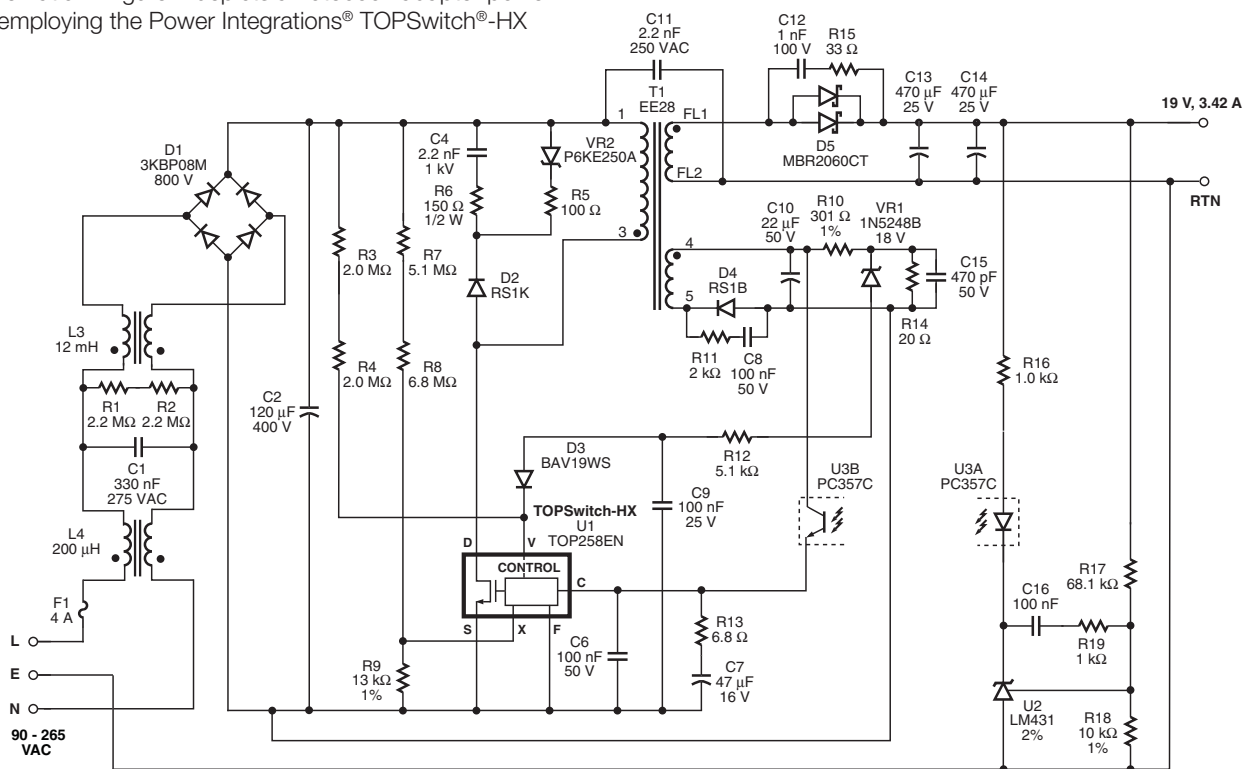

Figure 1. 65 W Notebook Adapter Schematic.

PI-5192-071608

Capacitor C7 charges at start up through the Drain (D) pin, initiating switching in U1. After start up the bias winding powers the controller. Resistor R13 provides compensation to the feedback loop.

The clamp network formed by VR2, C4, R5, R6, and D2 limits the drain voltage (preventing spikes at MOSFET turn off) and dissipates transformer leakage inductance energy. Capacitor C4 does not discharge below the value of VR2 during low frequency operating modes for reduced consumption at light or no load conditions. Resistor R6 dampens high-frequency ringing.

Resistors R7, R8, and R9 reduce the external current limit of U1 as the line voltage increases, keeping the output power to <100 VA at high line, and ensuring the rated output at low line, and a constant output power level with changing line voltages. Line-sensing resistors R3 and R4 (4 M $\Omega$ ) set the undervoltage and overvoltage thresholds, and maximum duty cycle at specific voltages.

Open-loop faults cause VR1 to conduct, sending current into the V pin, and U1 into hysteretic overvoltage shutdown mode.

Schottky diode D5 rectifies the output. A snubber network (C12, R15) dampens ringing across the diodes and reduces high frequency conducted and radiated noise. Capacitors C13 and C14 provide output filtering. Resistors R17 and R18 provide a voltage divider and fix the output DC set point. Capacitor C16 and resistor R19 provide feedback control loop phase compensation. Resistor R16 sets the feedback system gain, ensuring stability over the entire operating range.

### Key Design Points

- The high-voltage (700 V) MOSFET in U1 enables using a higher transformer primary-to-secondary turns ratio and a 60 V, 20 A

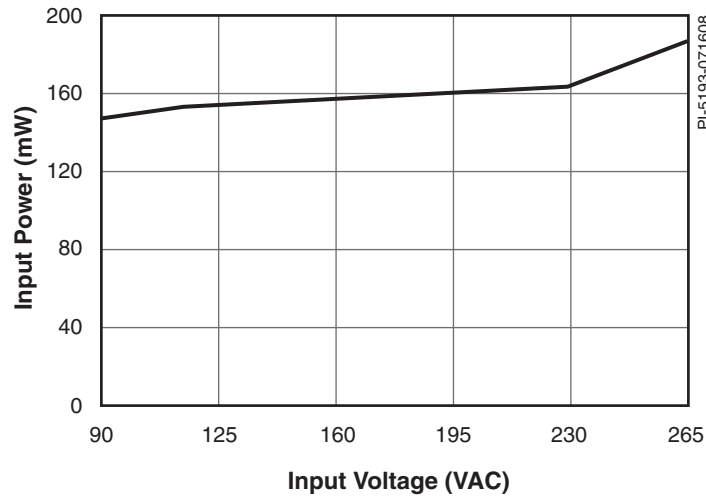

Figure 2. No-load Input Power vs. Line Voltage.

Power Integrations  
5245 Hellyer Avenue  
San Jose, CA 95138, USA.  
Main: +1 408-414-9200  
Customer Service  
Phone: +1-408-414-9665  
Fax: +1-408-414-9765  
Email: usasales@powerint.com

On the Web  
www.powerint.com

Power Integrations reserves the right to make changes to its products at any time to improve reliability or manufacturability. Power Integrations does not assume any liability arising from the use of any device or circuit described herein. POWER INTEGRATIONS MAKES NO WARRANTY HEREIN AND SPECIFICALLY DISCLAIMS ALL WARRANTIES INCLUDING, WITHOUT LIMITATION, THE IMPLIED WARRANTIES OF MERCHANTABILITY, FITNESS FOR A PARTICULAR PURPOSE, AND NON-INFRINGEMENT OF THIRD PARTY RIGHTS. The products and applications illustrated herein (transformer construction and circuits external to the products) may be covered by one or more U.S. and foreign patents or potentially by pending U.S. and foreign patent applications assigned to Power Integrations. A complete list of Power Integrations' patents may be found at [www.powerint.com](http://www.powerint.com). Power Integrations grants its customers a license under certain patent rights as set forth at <http://www.powerint.com/ip.htm>.

The PI logo, TOPSwitch, TinySwitch, LinkSwitch, DPA-Switch, PeakSwitch, EcoSmart, Clampless, E-Shield, Filterfuse, StackFET, PI Expert and PI FACTS are trademarks of Power Integrations, Inc. Other trademarks are property of their respective companies. ©2008, Power Integrations, Inc.

Schottky output diode (vs. a 100 V, 40 A diode) for increased efficiency and lowered cost.

- Ensure bypass capacitor C6 is placed as physically close as possible to U1.
- To change the overvoltage shutdown to a latching shutdown, reduce R12 until >336  $\mu$ A flows into the V pin during open-loop conditions.
- IC U1 shuts down when the junction temperature reaches +142  $^{\circ}$ C and automatically recovers when this temperature decreases by 75  $^{\circ}$ C.

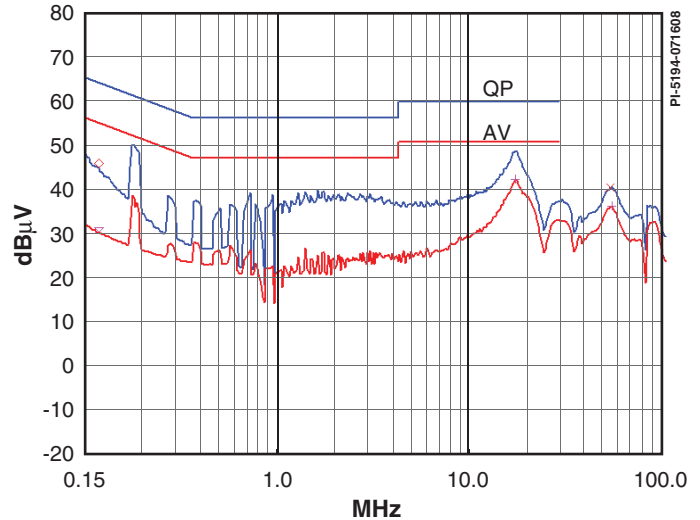

Figure 3. Conducted EMI Scan, EN55022 B Limits. Measurements Made at 230 VAC with Output RTN Grounded.

### Transformer Parameters

<b>Core Material</b>	EE28 PC44 gapped to ALG of 478 nH/t <sup>2</sup>
<b>Bobbin</b>	EE28, 10 pin, Vertical
<b>Winding Details</b>	Bias/Feedback: 2T $\times$ 4, 32 AWG Primary 1 <sup>st</sup> Half: 16T $\times$ 2, 25 AWG Shield: 1T, Foil, 2 mils thick (reverse wound) Secondary: 3T $\times$ 4, 24 TIW Shield: 1T, Foil, 2 mils thick Primary 2 <sup>nd</sup> Half: 15T $\times$ 2, 25 AWG
<b>Winding Order</b>	Bias/Feedback (4-5), Primary 1 <sup>st</sup> Half (3-2), Shield (NC-1), Secondary (FL1-FL2), Shield (NC-10), Primary 2 <sup>nd</sup> Half (2-1)
<b>Primary Inductance</b>	452 $\mu$ H, $\pm$ 5%
<b>Primary Resonant Frequency</b>	1 MHz (minimum)
<b>Leakage Inductance</b>	5 $\mu$ H (maximum)

Table 1. Transformer Parameters. (TIW = Triple Insulated Wire, AWG = American Wire Gauge, NC = No Connection)