

# DI-196 Design Idea

## TOPSwitch-HX

### 65 W Ultra-low Profile (15.4 mm) Adapter

Application	Device	Power Output	Input Voltage	Output Voltage	Topology
Notebook Adapter	TOP261LN	65 W	90 – 265 VAC	19.7 V	Flyback

#### Design Highlights

- Low cost, low component count
- Very compact design in a thin case (15.4 mm)
- Very low no-load input power (<270 mW at 230 VAC)
- Meets Energy Star 2.0 Efficiency Requirements:
  - >88% at both 115 V / 60 Hz and 230 V / 50 Hz
  - Very high efficiency in both standby and sleep modes
- Excellent transient load response
- Hysteretic thermal overload protection with automatic recovery
- Latching overvoltage protection (OVP) with fast AC reset
- Meets limited power source requirements (<100 VA) with single-point failure
- Form-fit advantages from Power Integrations
  - eSIP low-profile package
  - proprietary SlimCore ultra-low profile transformer bobbin design

#### Operation

The notebook adapter power supply shown in Figure 1 features the Power Integrations® TOPSwitch-HX TOP261LN in a flyback configuration, using a universal input to deliver a 65 W, 19.7 V

output. The features designed into the TOP261LN (U11) provide the type of protection important to a notebook adapter such as OVP, latching shutdown, and hysteretic thermal-overload protection.

All TOPSwitch-HX devices feature EcoSmart® to provide constant efficiency over full specified load range. EcoSmart utilizes multi-cycle modulation (MCM), a proprietary, automatic function that eliminates special operating modes usually necessary at specific load thresholds. This simplifies and optimizes circuit design for meeting future energy efficiency regulation changes without redesign.

Capacitor C66 at the input reduces differential mode EMI, while Resistors R63 and R64 provide a discharge path upon AC removal to prevent shock. Bridge rectifier D25 rectifies the AC. Bulk capacitors C63 and C64 filter the resulting DC. A line-sensing network (D26 and C70) enables implementation of a fast AC reset function. A clamp network (C43, R93, R62, D18, VR2, and R72) prevents voltage spikes at the Drain (D) pin upon MOSFET switch turn-off. Y-capacitor C41 reduces common-mode EMI, as does common-mode inductor L1.

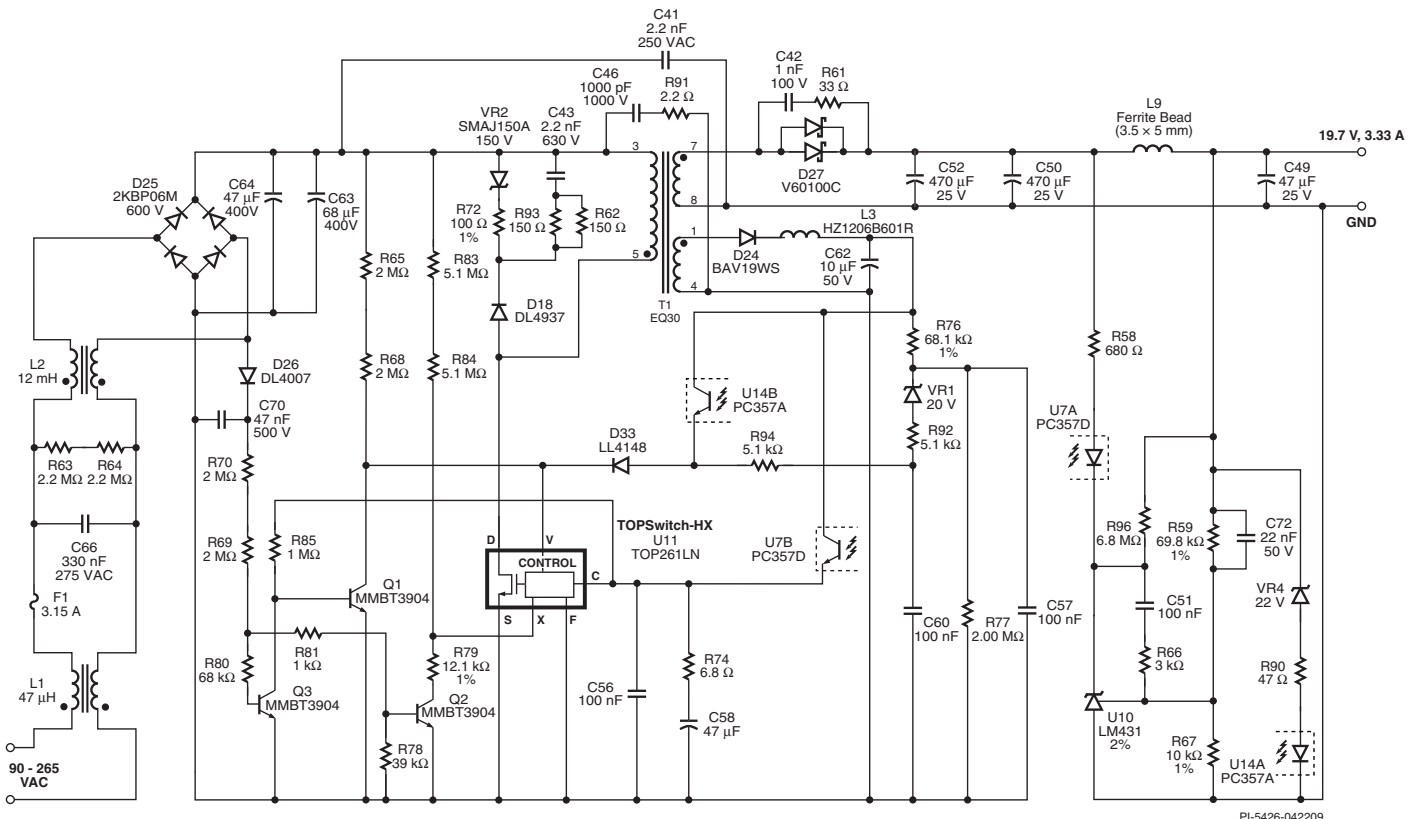

Figure 1. 65 W Notebook Adapter Schematic.

During normal operation Q3 pulls the base of Q1 down, keeping it off. The current through R65 and R68 and into the V pin is proportional to the DC bus voltage. A current exceeding 25  $\mu$ A at the V pin defines undervoltage (UV) threshold at approximately 100 VDC or 70 VAC. IC U11 begins to switch at this point, turning on the power supply. Below the UV threshold Q2 turns off causing the X pin to float, disabling U11. This is to prevent output glitching during reset of a latched shutdown condition.

Resistors R83, R84, and R79 reduce the internal current limit of U11 as the line voltage increases. This limits output power to <100 VA at high line and delivers the rated output at low line.

On the secondary side, C42 and R61 dampen ringing across output diode D27. Filtering of the rectified output is provided by C52, C50, L9, and C49. Feedback from the output to the CONTROL (C) pin, which regulates the output by adjusting the effective duty cycle of the internal MOSFET, is provided by U7.

The rise in voltage on the primary side bias winding during overload is used to provide a time-triggered overload protection function. The values of C57, R76, and R77 insert a trigger delay to prevent false shutdown during valid transient loads. If an overload condition lasts longer than the trigger delay while keeping the voltage across C62 over 20 V, the auto-recovery shutdown on the V pin is triggered.

For further protection, VR4 and U14 provide a simple latching shutdown function in the even of open-loop faults which cause excessive output voltage. When the output reaches approximately 23 V, U14 conducts and sends current into the V pin exceeding the shutdown threshold, shutting down the supply.

To turn the power supply back on immediately after such a shutdown, cycle the AC input: Remove the AC to reset U11, then reapply AC. Once UV threshold is exceeded the supply restarts.

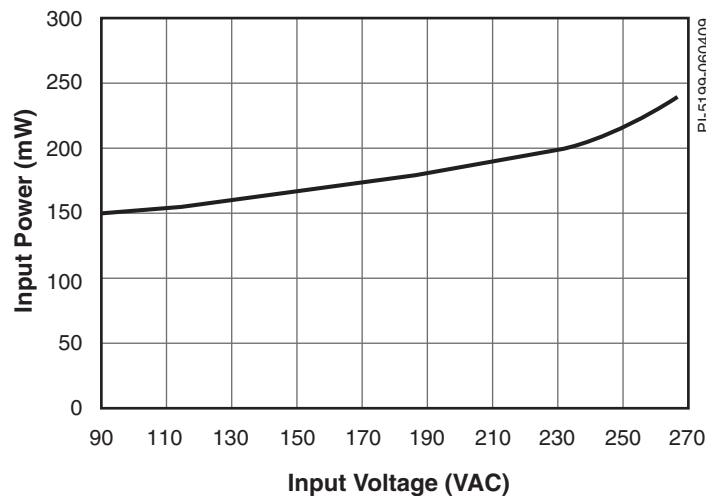

Figure 2. No-load Input Power vs. Line Voltage.

IC U11 also features an integrated hysteretic thermal-overload protection function. If the junction temperature (in U11) reaches +142  $^{\circ}$ C, U11 shuts down. It automatically recovers once the junction temperature has decreased by approximately 75  $^{\circ}$ C.

### Key Design Points

- Change the overload shutdown feature to a latching shutdown by replacing R92 with a resistor smaller than 100  $\Omega$ .
- If a fast AC reset is not required then Q1, Q2, Q3 plus associated components can be eliminated.

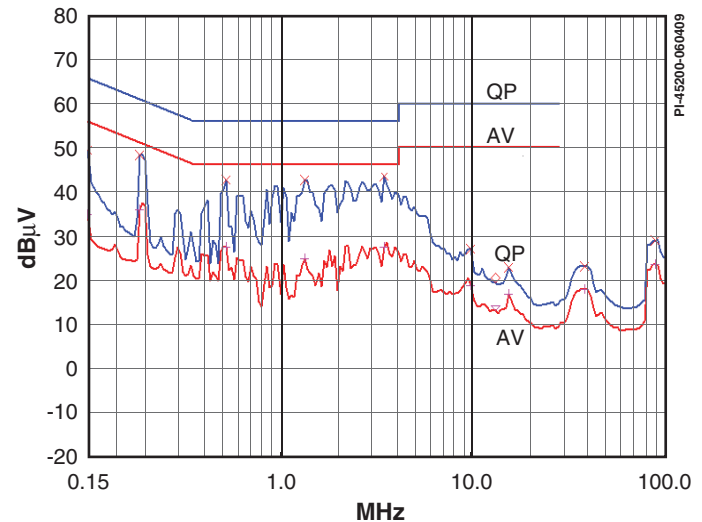

Figure 3. Conducted EMI scan, EN55022 B Limits. Measurements made at 230 VAC, 6  $\Omega$  Resistive Load, Output RTN connected to PE.

### Transformer Parameters

<b>Core Material</b>	3F35 Ferroxcube EQ30, PLT30/20/3 AL = 4600 nH/t <sup>2</sup> (ungapped)
<b>Bobbin</b>	PIEQ30, Vertical, 5-5 pins (Power Integrations SlimCore bobbin)
<b>Winding Details</b>	Secondary 1 <sup>st</sup> Half: 2T $\times$ 2, 24 TIW Winding Cancellation: 3T $\times$ 3, 32 AWG Primary: 24T, 26 AWG Secondary 2 <sup>nd</sup> Half: 2T $\times$ 2, 24 TIW Feedback/Bias: 3T $\times$ 3, 32 AWG
<b>Winding Order</b>	Secondary 1 <sup>st</sup> Half (7–9), Winding Cancellation (4–2), Primary (5–3), Secondary 2 <sup>nd</sup> Half (9–8), Feedback Bias (1–4)
<b>Primary Inductance</b>	375–400 $\mu$ H
<b>Primary Resonant Frequency</b>	1000 kHz (minimum)
<b>Leakage Inductance</b>	6 $\mu$ H (maximum)

Table 1. Transformer Parameters. (TIW = Triple Insulated Wire, AWG = American Wire Gauge, NC = No Connection)

Power Integrations  
5245 Hellyer Avenue  
San Jose, CA 95138, USA.  
Main: +1 408-414-9200  
Customer Service  
Phone: +1-408-414-9665  
Fax: +1-408-414-9765  
Email: usasales@powerint.com

Power Integrations reserves the right to make changes to its products at any time to improve reliability or manufacturability. Power Integrations does not assume any liability arising from the use of any device or circuit described herein. POWER INTEGRATIONS MAKES NO WARRANTY HEREIN AND SPECIFICALLY DISCLAIMS ALL WARRANTIES INCLUDING, WITHOUT LIMITATION, THE IMPLIED WARRANTIES OF MERCHANTABILITY, FITNESS FOR A PARTICULAR PURPOSE, AND NON-INFRINGEMENT OF THIRD PARTY RIGHTS. The products and applications illustrated herein (transformer construction and circuits external to the products) may be covered by one or more U.S. and foreign patents or potentially by pending U.S. and foreign patent applications assigned to Power Integrations. A complete list of Power Integrations' patents may be found at [www.powerint.com](http://www.powerint.com). Power Integrations grants its customers a license under certain patent rights as set forth at <http://www.powerint.com/ip.htm>.

On the Web  
[www.powerint.com](http://www.powerint.com)

The PI logo, TOPSwitch, TinySwitch, LinkSwitch, DPA-Switch, PeakSwitch, EcoSmart, Clampless, E-Shield, Filterfuse, StackFET, PI Expert and PI FACTS are trademarks of Power Integrations, Inc. Other trademarks are property of their respective companies.  
©2008, Power Integrations, Inc.