

DI-16参考设计 TOPSwitch-GX

57 W、230 VAC多输出机顶盒电源

应用	器件	输出功率	输入电压	输出电压	拓扑结构
机顶盒	TOP246YN	43 W cont, 57 W pk	180 – 265 VAC	3.3 V / 5 V / 12 V / 18 V / 33 V	反激式

设计特色

- 高效率，180 VAC时效率>75%
- 未使用线性调整器也可实现较好的交叉调整率
- 线欠压检测 (UV) 和过压(OV)浪涌保护
- 满足CISPR22B/EN55022B对传导EMI的要求
- 通过4 kV的差模和共模浪涌测试 (EN61000-4-5)
- 通过4 kV/100 kHz震铃波测试 (IEEE C62.41)

设计要点

- R1 (2 M Ω , 0.5 W) 将UV设置为100 VDC, OV设置为450 VDC。要使用一个0.5 W的电阻以使额定电压大于350 VDC。
- 集成的OV关断可承受长时间的线电压浪涌 (在一些国家较常见)。在关断时, 漏极电压不会超过DC输入电压 (漏极不进行

开关操作), 可使AC线电压上升到495 VAC (700 VDC BV_{DSS} 额定) 而不会损坏TOPSwitch-GX。

- 变压器T1有一个分槽的骨架, 可自动绕制和装配。
- 变压器匝比进行了优化设计 (包括输出整流管正向压降), 使3.3 V和5 V的输出电压容差最小。
- 反馈取自3.3 V和5 V输出, 通过R10、R11和R13接到参考 (U3)。其他输出电压通过变压器变比设置。为了得到强化的调整率并使输出电压位于中心值, 12 V、18 V和33 V输出应直流叠加到5 V输出。在33 V负载很轻时需要增加假负载R14以维持33 V的输出。
- 软启动电容 (C20) 消除了开机输出过冲。
- 为了得到更低的输出纹波, 所有输出都用了LC后级滤波 (L2-6和C8、10、12、15、18)。



图1. 使用TOPSwitch-GX的60 W机顶盒电源

PI-3395-092908

- 初级箝位元件VR1和D5把漏感产生的峰值漏极电压控制到一个安全值。R2和C5降低了VR1的功率损耗。
- 频率抖动使用简单滤波提供大的EMI裕量。

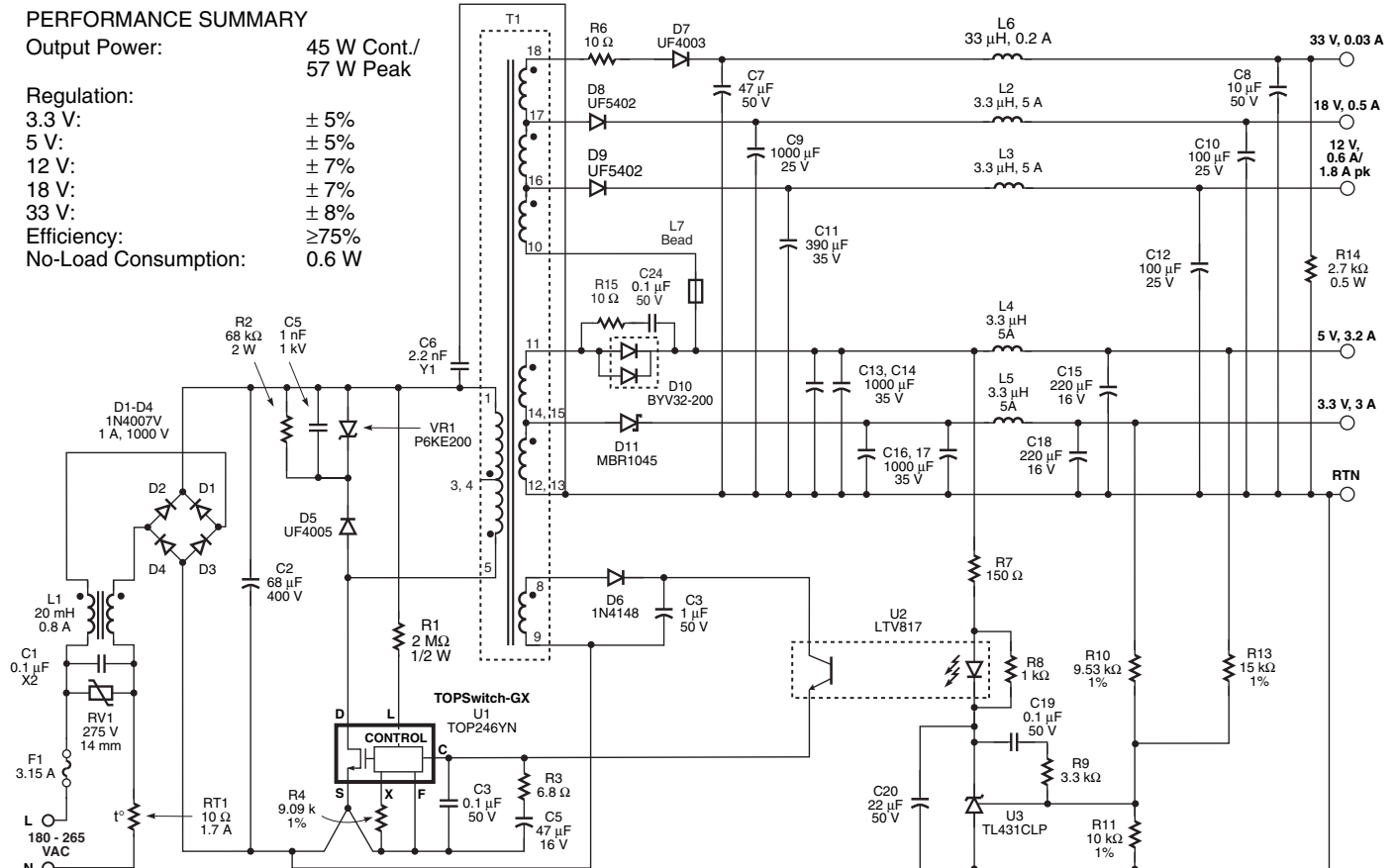

图2. 传导EMI (230 VAC, 43 W)

绕线说明

Slot 1	Start Pin 5	26T	0.25 mm	Finish Pin 3
Slot 2	Start Pin 11	1T	0.25 mm	Finish Pin 14
	Start Pin 14	2T	0.25 mm	Finish Pin 12
	Start Pin 16	4T	0.25 mm	Finish Pin 10
	Start Pin 17	3T	0.25 mm	Finish Pin 16
Slot 3	Start Pin 18	6T	0.25 mm	Finish Pin 17
	Start Pin 3	26T	0.25 mm	Finish Pin 1
Slot 4	Start Pin 8	7T	0.25 mm	Finish Pin 9
	Start Pin 11	1T	0.25 mm	Finish Pin 14
	Start Pin 14	2T	0.25 mm	Finish Pin 12
Slot 5	Start Pin 14	2T	0.25 mm	Finish Pin 12
	Start Pin 5	26T	0.25 mm	Finish Pin 4
Slot 6	Start Pin 11	1T	0.25mm	Finish Pin 15
	Start Pin 15	2T	0.25mm	Finish Pin 13
	Start Pin 15	2T	0.25 mm	Finish Pin 13
	Start Pin 16	4T	0.25 mm	Finish Pin 10
Slot 7	Start Pin 4	26T	0.25 mm	Finish Pin 1
Slot 8	Start Pin 11	1T	0.25 mm	Finish Pin 15
	Start Pin 15	2T	0.25 mm	Finish Pin 13
	Start Pin 16	4T	0.25 mm	Finish Pin 10
	Start Pin 17	3T	0.25 mm	Finish Pin 16
Slot 9	Start Pin 18	6T	0.25 mm	Finish Pin 17
	Start Pin 5	26T	0.25 mm	Finish Pin 4

表1. 变压器制造信息

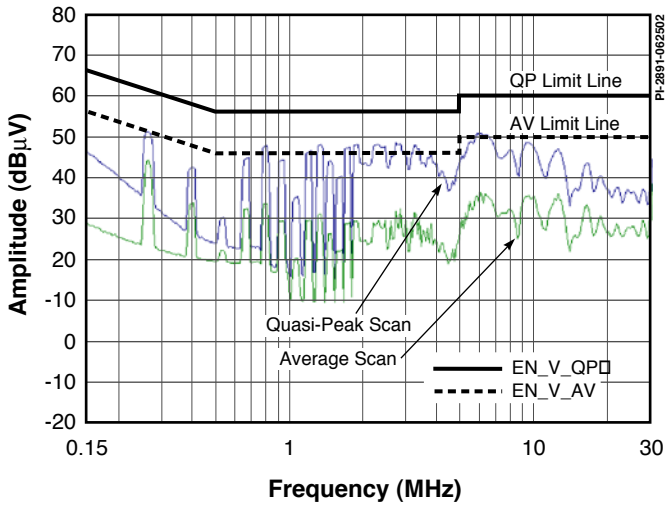
变压器参数

磁芯 & 骨架	Omega SMT 18 core/bobbin set, gapped for 180 nH/t ²
初级电感量 (pins 1-5, with pins 3-4 shorted together, all other windings open)	487 µH, ±10%
初级谐振频率 (和上面同样的测试条件)	2 MHz (minimum)
漏感 Inductance (pins 1-5, with pins 3-4 shorted, pins 10-18 shorted)	15 µH (maximum)

表2. 变压器电参数

Power Integrations
5245 Hellyer Avenue
San Jose, CA 95138, USA.
Main: +1 408-414-9200
Customer Service
Phone: +1-408-414-9665
Fax: +1-408-414-9765
Email: usasales@powerint.com

On the Web
www.powerint.com

Power Integrations reserves the right to make changes to its products at any time to improve reliability or manufacturability. Power Integrations does not assume any liability arising from the use of any device or circuit described herein. POWER INTEGRATIONS MAKES NO WARRANTY HEREIN AND SPECIFICALLY DISCLAIMS ALL WARRANTIES INCLUDING, WITHOUT LIMITATION, THE IMPLIED WARRANTIES OF MERCHANTABILITY, FITNESS FOR A PARTICULAR PURPOSE, AND NON-INFRINGEMENT OF THIRD PARTY RIGHTS. The products and applications illustrated herein (transformer construction and circuits external to the products) may be covered by one or more U.S. and foreign patents or potentially by pending U.S. and foreign patent applications assigned to Power Integrations. A complete list of Power Integrations' patents may be found at www.powerint.com. Power Integrations grants its customers a license under certain patent rights as set forth at <http://www.powerint.com/ip.htm>.

The PI logo, TOPSwitch, TinySwitch, LinkSwitch, DPA-Switch, PeakSwitch, EcoSmart, Clampless, E-Shield, Filterfuse, StackFET, PI Expert and PI FACTS are trademarks of Power Integrations, Inc. Other trademarks are property of their respective companies. ©2002, Power Integrations, Inc.