

DI-141 Design Idea

LinkSwitch-XT[®]

0.75 W, Anti-Tampering Energy Meter Power Supply

Application	Device	Power Output	Input Voltage	Output Voltage	Topology
Metering	LNK363DN	0.75 W	85-265 VAC	5 V	Flyback

Design Highlights

- Low cost, low component-count solution
- Powered iron core material increases immunity from tampering
 - Normal operation maintained under influence of external magnetic fields
- Low operating flux density (400 Gauss) for low core losses (<40 mW)
- High efficiency (58 %) at full load
 - Maximizes power available from input (2 W, 10 VA limit per IEC1036)
 - Maximizes holdup time
- Holdup time energy stored in input capacitance
 - Eliminates need for large output capacitor or second higher output voltage
- Meets EN55022B conducted EMI with >6 dB μ V margin

Operation

The schematic shown in Figure 1 employs LNK363DN to generate a 5 V, 150 mA isolated output. The transformer has been designed to have sufficient inductance for the power supply to deliver the power required, even if the core has saturated as a result of attempted meter tampering, by applying a large external magnetic field.

Diodes D1 through D4 are used to rectify the AC input. Capacitors C1 and C2 filter the rectified DC. Inductors L1, C1, and C2 form a pi filter that attenuates differential mode conducted EMI. Using ON/OFF control, U1 skips switching cycles to regulate the output voltage, based on feedback to its FB pin. When the current delivered into this pin exceeds 49 μ A, a low logic level (disable) is generated. At the beginning of each cycle the FB pin state is sampled; if high, the power MOSFET is turned on for that cycle (enabled); otherwise the power MOSFET remains off (disabled).

The output voltage is determined by the series sum of the voltages across the Zener diode reference VR1 (3.9 V) and the LED in U2 (1.1 V). Resistor R3 provides a constant bias current for VR1 such that it operates at its test current.

One common tampering method for electricity meters with a switching supply is to apply a large external magnetic field. This field couples into and saturates the core of the transformer. In the case of alternative solutions, this often causes a destructive failure of the MOSFET due to over-current. With devices from Power Integrations, the fast current limit protects the internal MOSFET,

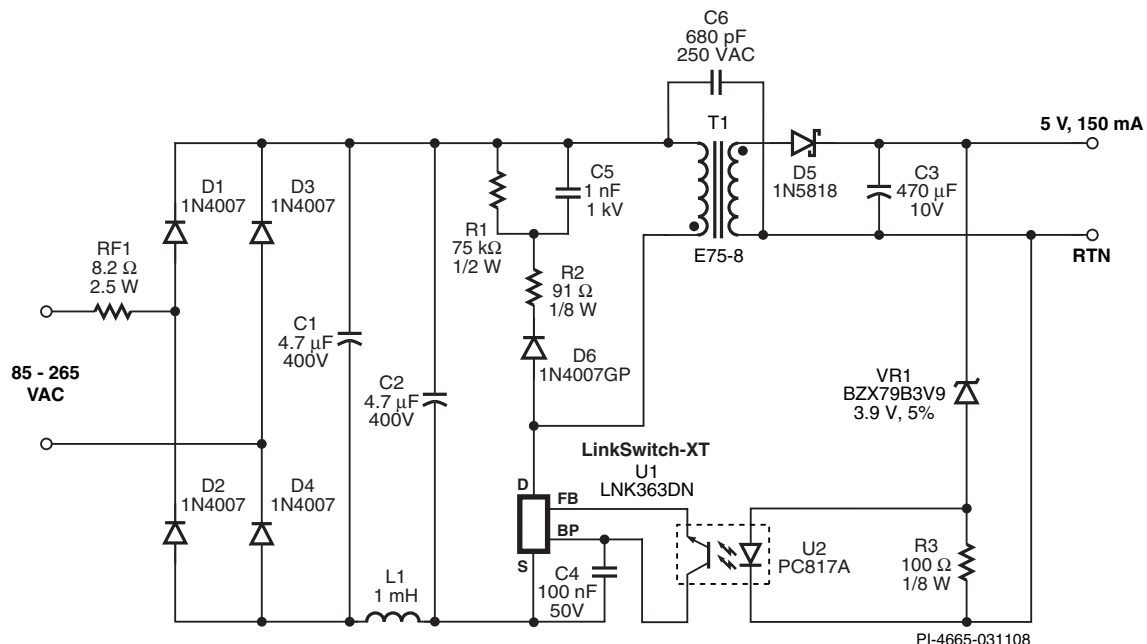

Figure 1. Schematic of a 5 V, 150 mA Supply Using a Powdered Iron Core for Increased Immunity to External Magnetic Field.

but the output falls out of regulation, stopping the meter. Several solutions exist to get around this problem. An air core transformer never saturates but needs a very large number of turns. The resulting high copper losses and leakage inductance lead to extremely poor efficiency (~ 20%). A standard ferrite cored transformer can be used if magnetic shielding material is used to box the transformer, shunting flux away from the core and preventing saturation. This adds cost and complexity as a custom shield is needed for each new design.

This design solves these issues by replacing the ferrite cores with a high reluctance powdered iron material with a distributed air gap. This core has very low relative permeability (μ_r between 10 and 35). Powdered iron cores have a much higher saturation flux density, 15,000 Gauss (1.5 T) compared to 4000 Gauss (0.4 T) for ferrites, and have much softer saturation characteristics than ferrites.

Magnetic susceptibility tests were carried out using strong electromagnets as well as permanent earth magnets. One pole of the magnet was placed directly on top of the core, and no saturation of the core was seen (drain current is shown in Figure 2).

Key Design Points

- Use PI XIs to design the transformer. To design for a saturated transformer, enter a transformer tolerance of 60%. At or close to saturation, the primary inductance drops, and the high tolerance figure ensures the inductance value is sufficient for power delivery.
- The number of turns is high due to the high reluctance of the core. This also has the benefit of very low operating flux density (400 Gauss), which allows for very high margin to core saturation.
- Ensure that under saturation conditions the peak drain current at full load and maximum input voltage is below the data sheet maximum current.
- To minimize core losses, the operating AC flux swing should be limited to 300 Gauss or less. This means that the peak flux density should be kept below 600 Gauss.

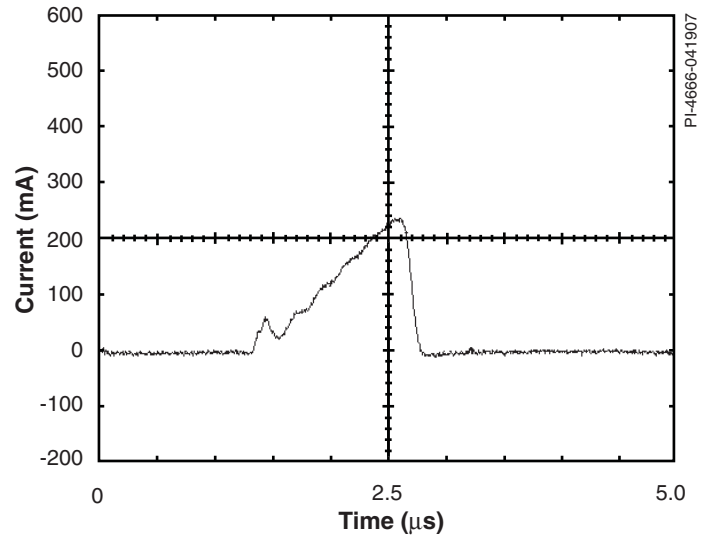

Figure 2. Drain Current Under Influence of a Magnetic Dipole Indicating No-core Saturation. (Scale – 100 mA/div).

Transformer Parameters

Core Material	E75-8 powdered iron material with AL of 33.5 nH/t ² , Manufacturer – Micrometals
Bobbin	US LAM EI187, 9 pin
Winding Details	Primary: 132T, 36 AWG, 2 layers, 3 layers of tape Secondary: 9T, 25 AWG TIW, 1 layer
Winding Order	Primary (2-4), Secondary (5,6-8,9)
Primary Inductance	600 µH, ±10%
Resonant Frequency	900 kHz (minimum)
Leakage Inductance	80 µH (maximum)

Table 1. Transformer Parameters.
(AWG = American Wire Gauge, TIW = Triple Insulated Wire, NC = No Connection).

Power Integrations
5245 Hellyer Avenue
San Jose, CA 95138, USA.
Main: +1 408-414-9200
Customer Service
Phone: +1-408-414-9665
Fax: +1-408-414-9765
Email: usasales@powerint.com

On the Web
www.powerint.com

B
03/08

Power Integrations reserves the right to make changes to its products at any time to improve reliability or manufacturability. Power Integrations does not assume any liability arising from the use of any device or circuit described herein. POWER INTEGRATIONS MAKES NO WARRANTY HEREIN AND SPECIFICALLY DISCLAIMS ALL WARRANTIES INCLUDING, WITHOUT LIMITATION, THE IMPLIED WARRANTIES OF MERCHANTABILITY, FITNESS FOR A PARTICULAR PURPOSE, AND NON-INFRINGEMENT OF THIRD PARTY RIGHTS. The products and applications illustrated herein (transformer construction and circuits external to the products) may be covered by one or more U.S. and foreign patents or potentially by pending U.S. and foreign patent applications assigned to Power Integrations. A complete list of Power Integrations' patents may be found at www.powerint.com. Power Integrations grants its customers a license under certain patent rights as set forth at <http://www.powerint.com/ip.htm>.

The PI logo, TOPSwitch, TinySwitch, LinkSwitch, DPA-Switch, PeakSwitch, EcoSmart, Clampless, E-Shield, Filterfuse, StackFET, PI Expert and PI FACTS are trademarks of Power Integrations, Inc. Other trademarks are property of their respective companies.
©2007, Power Integrations, Inc.