

DI-132 Design Idea

LinkSwitch-LP

1.75 W, High Efficiency, Linear Charger Replacement

Application	Device	Power Output	Input Voltage	Output Voltage	Topology
Charger	LNK564DN	1.75 W	90 – 265 VAC	5 V	Flyback

Design Highlights

- SO-8 package enables small PCB (1.12 × 0.89 inches)
- High switching frequency (100 kHz) enables use of small, lightweight transformer (EE-13)
- Low component count design: only 16 parts
- Output power level and MOSFET current limit allow the MOSFET drain node to be left Clamless™
- Half-wave rectification allows input conducted EMI filter inductor to be used in the Filterfuse™ configuration
- Meets CEC 2008 standards for active-mode efficiency (64% vs 55% required minimum)
- <100 mW no-load input power consumption at 230 VAC
- Meets CISPR-22/EN55022 B conducted EMI limits without a Y-capacitor
- Constant-voltage/constant-current (CV/CC) output characteristic is ideal for replacing 50/60 Hz transformer based chargers

Operation

The isolated flyback power supply shown in Figure 1 was designed around a member of the LinkSwitch-LP IC family, the LNK564DN (U1). It delivers up to 350 mA at 5 V (1.75 W) from a universal input voltage range of 90 – 265 VAC.

Diodes D1 and D2 half-wave rectify the AC input voltage. The bulk storage capacitor (C1) and L1 attenuate conducted EMI.

Inductor L1 is covered with heat-shrink tubing, which allows it to act as a fuse if there is a component failure.

The LNK564DN uses the reflection of the secondary winding voltage on the bias winding to regulate the output voltage and current, which eliminates the need for an optocoupler.

In the CV mode (from no-load to 1.75 W), regulation is maintained by skipping MOSFET switching cycles. When the current demanded by the load exceeds the peak power point, MOSFET switching cycles are no longer skipped and the internal oscillator frequency reduces proportionally with the voltage on the FEEDBACK (FB) pin, while it is between 0.8 V and 1.7 V, which provides the CC portion of the output VI curve. If the FB pin voltage is below 0.8 V, U1 will be in auto-restart mode. During auto-restart, about every 800 ms the controller enables MOSFET switching for approximately 100 ms. The LNK564DN will remain in auto-restart mode until the FB pin voltage rises above 0.8 V during the 100 ms of enabled MOSFET switching.

The LNK564DN's low MOSFET current limit (136 mA) and special transformer construction techniques enable the transformer (T1) to have a high winding capacitance and low leakage inductance. This combination allows the MOSFET DRAIN node to be left

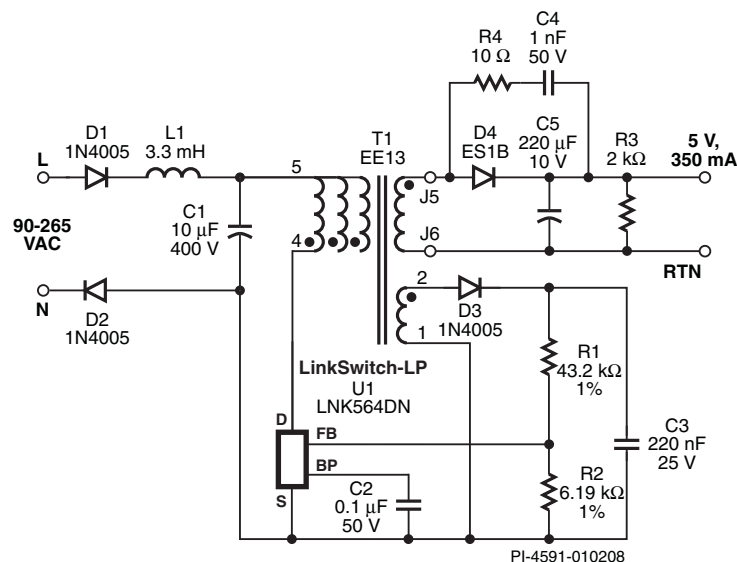

Figure 1. LNK564DN Based 5 V, 350 mA (1.75 W) Flyback Power Supply.

clampless, since the flyback voltage remains well below the 700 V DRAIN-to-SOURCE breakdown voltage (BV_{DS}) of U1 (see Figure 2).

The internal oscillator within U1 is frequency modulated (frequency jitter) to reduce EMI. Together with the E-Shield™ winding techniques used in transformer constructing and the attenuation of L1/C1, the supply meets CISPR-22 conducted EMI limits without requiring a Y-type capacitor.

Key Design Points

- Verify that the peak drain voltage is <650 V at high line, full load and no load conditions.
- 1% resistors should be used for R1 and R2, for the best output voltage and current accuracy.
- The snubber (R4 and C4) across the output diode is only required for radiated EMI. Replacing D4 with a Schottky diode can eliminate the need for that snubber circuit.
- For this converter to be left Clampless, the leakage inductance of the transformer must be very low (about 90 μH) and the primary winding capacitance must be fairly high (about 50 pF).
- The reflected output voltage (V_{OR}) should be less than 90 V to keep the peak of the flyback voltage spike below 650 V.

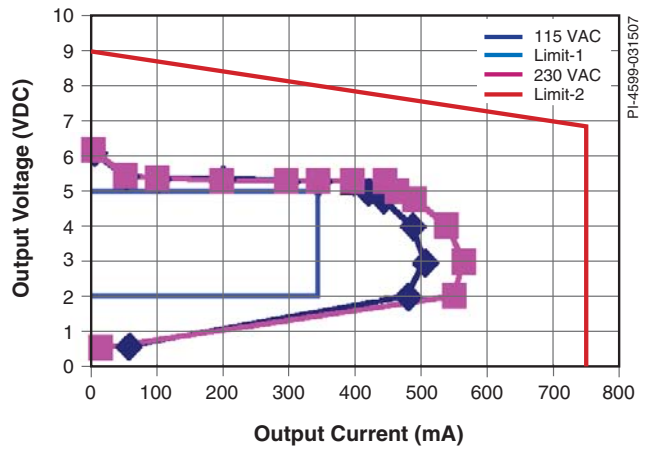

Figure 3. Output Voltage and Current (V-I) Characteristic.

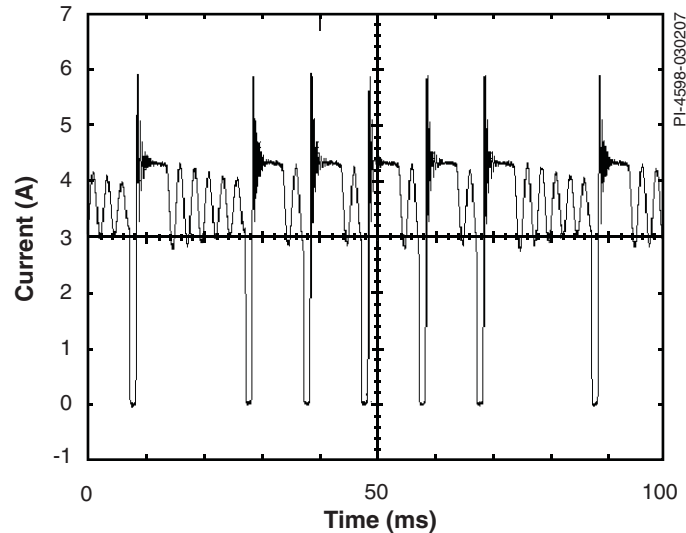

Figure 2. Drain Voltage at 265 VAC and Full Load. Flyback Voltage Spike Does Not Exceed 610 V, Even Without a Primary Clamp.

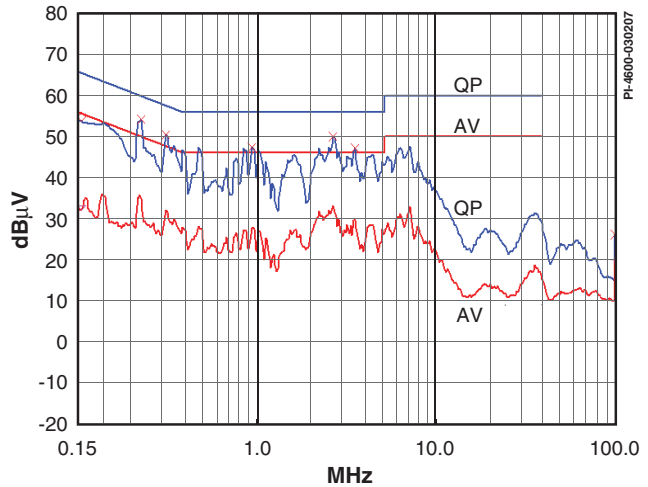

Figure 4. Conducted EMI Scan to EN55022 B Limits. 5 V, 350 mA at 230 VAC With Artificial Hand Connected to Sec RTN.

Power Integrations
 5245 Hellyer Avenue
 San Jose, CA 95138, USA.
 Main: +1 408-414-9200
 Customer Service
 Phone: +1-408-414-9665
 Fax: +1-408-414-9765
 Email: usasales@powerint.com

On the Web
 www.powerint.com

Power Integrations reserves the right to make changes to its products at any time to improve reliability or manufacturability. Power Integrations does not assume any liability arising from the use of any device or circuit described herein. POWER INTEGRATIONS MAKES NO WARRANTY HEREIN AND SPECIFICALLY DISCLAIMS ALL WARRANTIES INCLUDING, WITHOUT LIMITATION, THE IMPLIED WARRANTIES OF MERCHANTABILITY, FITNESS FOR A PARTICULAR PURPOSE, AND NON-INFRINGEMENT OF THIRD PARTY RIGHTS. The products and applications illustrated herein (transformer construction and circuits external to the products) may be covered by one or more U.S. and foreign patents or potentially by pending U.S. and foreign patent applications assigned to Power Integrations. A complete list of Power Integrations' patents may be found at www.powerint.com. Power Integrations grants its customers a license under certain patent rights as set forth at <http://www.powerint.com/ip.htm>.

The PI logo, TOPSwitch, TinySwitch, LinkSwitch, DPA-Switch, PeakSwitch, EcoSmart, Clampless, E-Shield, Filterfuse, StackFET, PI Expert and PI FACTS are trademarks of Power Integrations, Inc. Other trademarks are property of their respective companies. ©2007, Power Integrations, Inc.