

DI-119 Design Idea

LinkSwitch-LP

Cordless Phone Linear Adapter Replacement With 10 kV Surge Withstand

Application	Device	Power Output	Input Voltage	Output Voltage	Topology
Cordless Phone/ Adapter	LNK562PN	1.6 W	85 – 265 VAC	7.7 V 210 mA	Flyback

Design Highlights

- Simple, low-cost, low parts count CV/CC solution
- Low no-load input power: <180 mW at 265 VAC
- Dramatically improved regulation over line frequency linear transformer
- Meets CEC 2008 requirements for active mode efficiency (63% vs. 54.2% requirement)
- Small, low-cost EE16 core size allows compact design
- >15 dB μ V margin to EN55022B conducted EMI limits
- No Y-capacitor gives low (<10 μ A) line frequency leakage current
- Meets 10 kV common mode and 2 kV differential mode surge (EN 1000-4-5 Class 4)

Operation

Supplies for cordless phones or answering machines often require a 10 kV common mode surge withstand capability to prevent damage to the telephone network during local lightning strikes. The design shown in Figure 1 meets this requirement while still being simple and low cost.

The LNK562PN device (U1) provides primary side sensed output voltage and current regulation, eliminating the need for an optocoupler. Using the PI Transformer Designer software, shield

windings were included in the transformer design. This allowed the circuit to meet EN55022 B conducted EMI limits without the use of a Y-rated safety capacitor bridging the primary to secondary isolation barrier.

The AC input is rectified and filtered by D1, D2 and C1, C6. The input capacitance is split to form a π filter with L1 and L3, with R5 damping the self resonance. Varistor RV1 provides surge protection for differential surges while RF1 provides filtering and fusing. The internal MOSFET of U1 drives the transformer primary, but the normal primary clamp network is not required due to the low current limit of U1. Skipping switching cycles based on the voltage sensed from the bias winding provides output regulation. Should the output of the supply be overloaded, then U1 lowers the switching frequency to limit the output current until ~ 2 V, when the unit enters auto-restart.

Elimination of the optocoupler and Y1 capacitor allowed the necessary printed circuit board (PCB) clearance and creepage to be obtained to withstand a 10 kV surge. The use of triple insulated wire for the secondary winding that terminates onto the PCB as flying leads (J4 & J5) allows the necessary creepage from primary to secondary. Figure 2 shows the PCB layout.

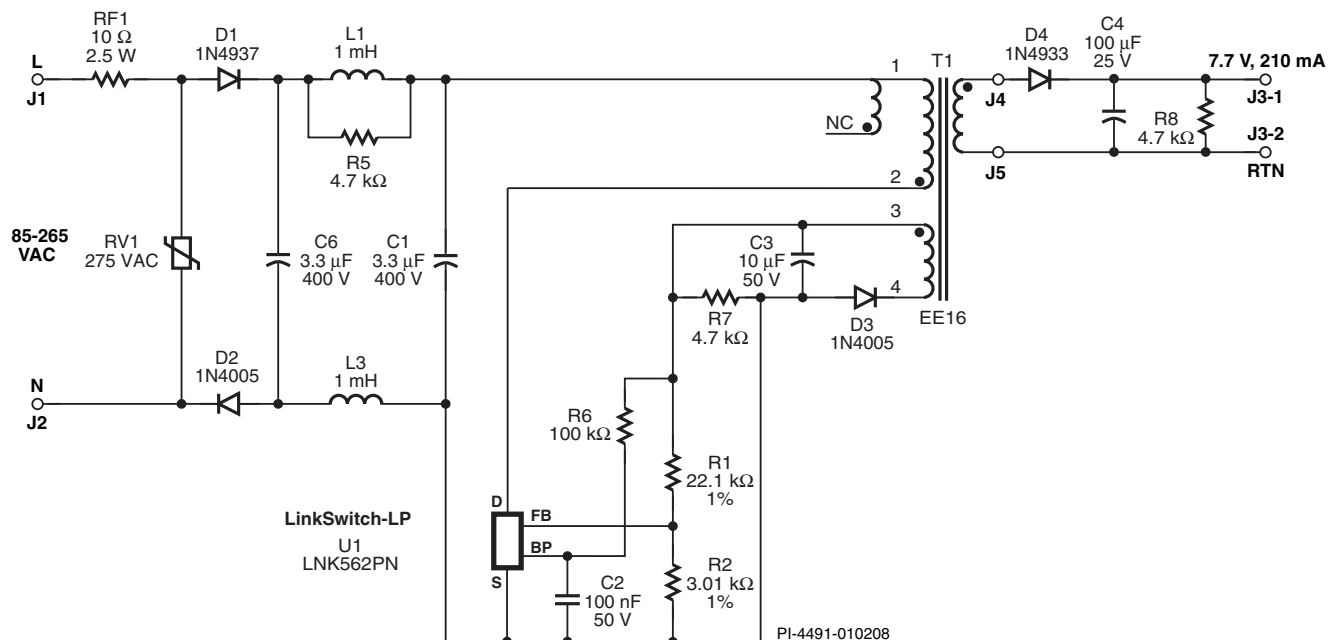

Figure 1. LNK562PN Linear Adapter Replacement Schematic.

Key Design Points

- Verify maximum drain voltage is <650 V at high line, maximum overload. For EMI repeatability, the transformer must be manufactured consistently. This is especially important in designs with no Y-capacitor.
- Using a fast diode for D1 improves EMI.
- Make sure the PCB layout provides 10 mm clearance and 15 mm creepage distance (use a slot in the PCB to increase creepage distance).
- Provide a path for surge discharge currents to go around sensitive electronic components (see spark gap (B) in Figure 2).
- To prevent arcing, keep the PCB surfaces clean. Remove flux and any other contaminants.

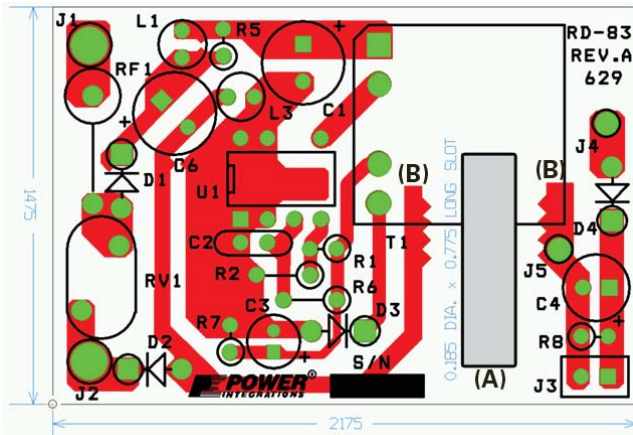

Figure 2. PCB Layout – Extended Clearance and Creepage Provided by Slot (A). Spark Gap Provided to Route High Currents Back to Input and Around Electronics (B).

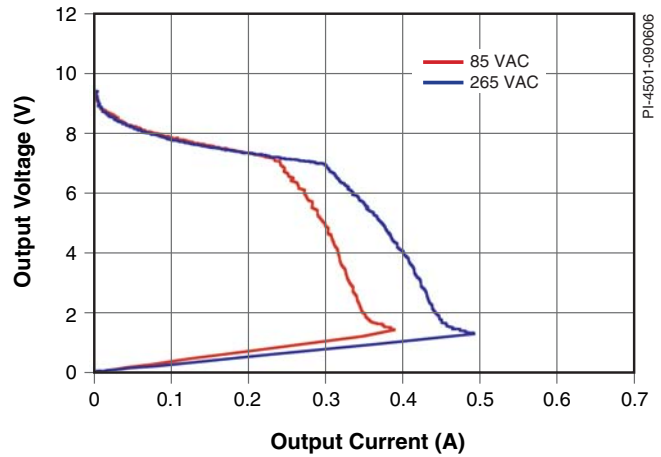

Figure 3. Typical Output Characteristics.

Transformer Parameters

Core Material	EE16, gapped for A_{LG} of 113 nH/t ²
Bobbin	4+4 pin horizontal
Winding Details	Bias/Shield: 29T, 2 × 37 AWG Primary: 176T, 37 AWG Shield: 15T, 2 × 32 AWG Secondary: 17T, 30 AWG T.I.W.
Winding Order (pin numbers)	Bias/Shield (3-4), tape Primary (2-1), tape Shield (NC-1), tape 7.7 V (FL-FL), tape
Inductance	Primary: 3.5 mH ±10% Leakage: 105 μH (maximum)
Primary Resonant Frequency	250 kHz (minimum)

Table 1. Transformer Parameters. (NC = No Connection, TIW = Triple Insulated Wire, FL = Flying Lead)

Power Integrations
5245 Hellyer Avenue
San Jose, CA 95138, USA.
Main: +1 408-414-9200
Customer Service
Phone: +1-408-414-9665
Fax: +1-408-414-9765
Email: usasales@powerint.com

On the Web
www.powerint.com

Power Integrations reserves the right to make changes to its products at any time to improve reliability or manufacturability. Power Integrations does not assume any liability arising from the use of any device or circuit described herein. POWER INTEGRATIONS MAKES NO WARRANTY HEREIN AND SPECIFICALLY DISCLAIMS ALL WARRANTIES INCLUDING, WITHOUT LIMITATION, THE IMPLIED WARRANTIES OF MERCHANTABILITY, FITNESS FOR A PARTICULAR PURPOSE, AND NON-INFRINGEMENT OF THIRD PARTY RIGHTS. The products and applications illustrated herein (transformer construction and circuits external to the products) may be covered by one or more U.S. and foreign patents or potentially by pending U.S. and foreign patent applications assigned to Power Integrations. A complete list of Power Integrations' patents may be found at www.powerint.com. Power Integrations grants its customers a license under certain patent rights as set forth at <http://www.powerint.com/ip.htm>.

The PI logo, TOPSwitch, TinySwitch, LinkSwitch, DPA-Switch, PeakSwitch, EcoSmart, Clampless, E-Shield, Filterfuse, StackFET, PI Expert and PI FACTS are trademarks of Power Integrations, Inc. Other trademarks are property of their respective companies. ©2006, Power Integrations, Inc.