

DI-117 Design Idea

TinySwitch-III

15 W, 12 V Adapter With <100 mW No-Load Consumption

Application	Device	Power Output	Input Voltage	Output Voltage	Topology
Adapters / General Purpose	TNY279PN	15 W	90 - 265 VAC	12 V	Flyback

Design Highlights

- Simple, low cost, low parts count solution
- Low input power at no-load: <100 mW at 265 VAC
- High efficiency >81% at 90 VAC
- Meets CEC 2008 requirements for active mode efficiency (79 % vs. 74.4 % requirement)
- >10 dB μ V margin to EN55022B conducted EMI limits
- Simple, primary-side output overvoltage latching shut-down protects load under fault conditions
- Low line frequency leakage current <10 μ A

Operation

The TNY279 (U1) in the 8-pin DIP package selected for the flyback design in Figure 1 is ideal for adapter applications. The arrangement of the four SOURCE pins on one side of the package allows a small metal heatsink to be inserted. This allows the device to operate in a sealed adapter with an external ambient of 40 °C.

The internal MOSFET in U1 conducts current through the primary winding of T1 during each enabled switching cycle. When the primary current reaches the MOSFET current limit, the controller turns it off, and the energy in T1 is transferred to the output.

Schottky diode D7 and capacitor C8 rectify and filter the output. Inductors L3 and capacitor C9 attenuate the switching ripple on the output. Capacitor C3 selects the standard current limit of U1. For higher efficiency, the next larger (TNY280P) device may be used. In this case, the value of C3 would be changed to 1 μ F, selecting the reduced current limit for the larger device, but no other circuit changes would be required.

The primary clamp (D5, R1, C5, R5 and R6) limits the maximum peak drain voltage below the 700 V breakdown voltage of U1's internal MOSFET. Resistor R1 dampens the high-frequency ringing of the T1 leakage inductance.

The built-in frequency jitter and E-Shield™ techniques allow simple EMI filtering to comply with EN55022B. Resistor R2 and C4 form an RC snubber to reduce high-frequency EMI.

Output overvoltage protection (OVP) is provided on the primary side by sensing the voltage of the auxiliary transformer winding. Should the main feedback loop open due to failure of U2, then U1 will latch off once the current into the BP/M pin (via VR3) exceeds 6.5 mA. Diode D6 and capacitor C7 rectify and smooth the

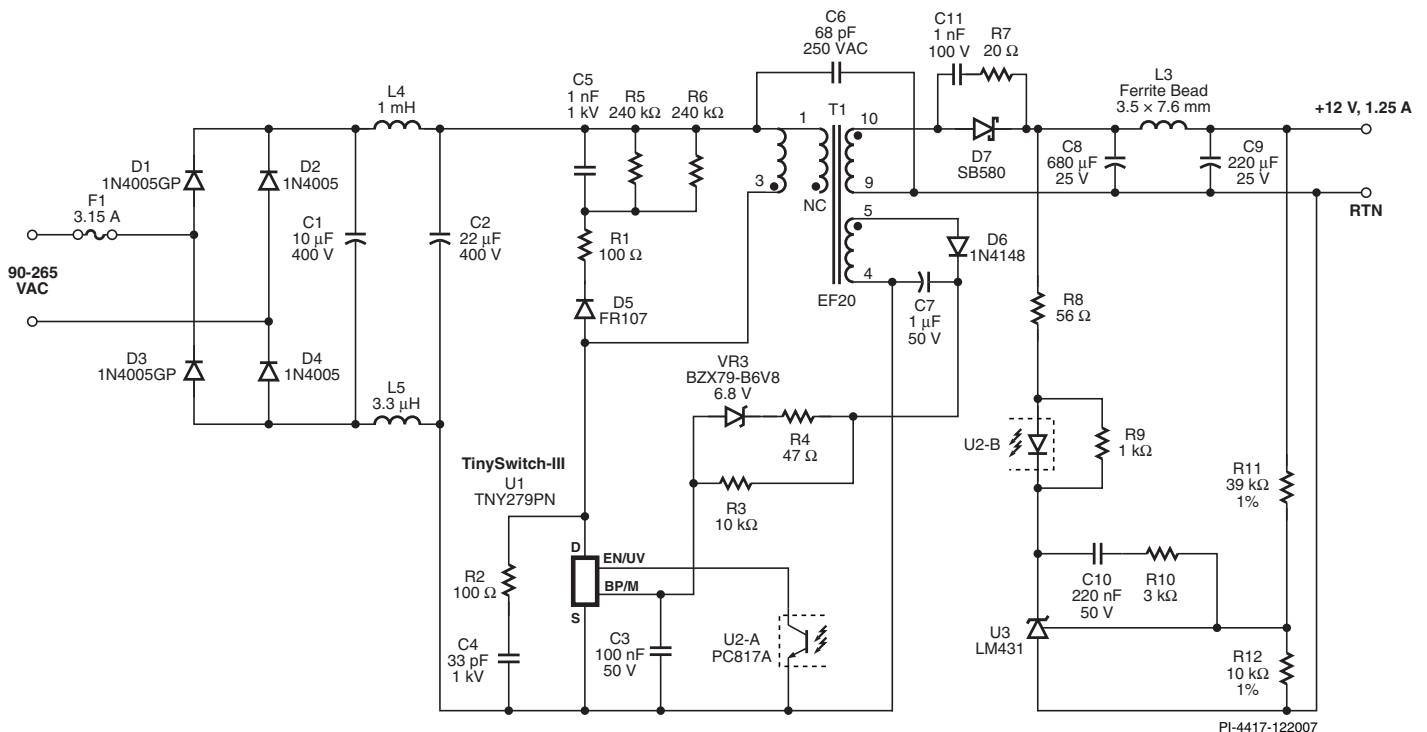

Figure 1. 15 W, 12 W Output Supply Using TNY279P.

PI-4417-122007

output of the auxiliary winding. The value of VR3 is selected to trigger the OVP latch when the main output, and hence the auxiliary output voltage, rises above the normal regulation range. Once triggered, cycling the AC power resets the OVP latch. To reduce no-load input power and thus increase light load efficiency, resistor R3 feeds the supply current for U1 from the auxiliary winding on the transformer.

Key Design Points

- Verify maximum drain voltage is <650 V at high line, maximum overload. Adjust values of R5, R6 and C5 accordingly. However, avoid making the clamp too dissipative (low value of R5 and R6, and high value of C5) as this will increase no-load consumption.

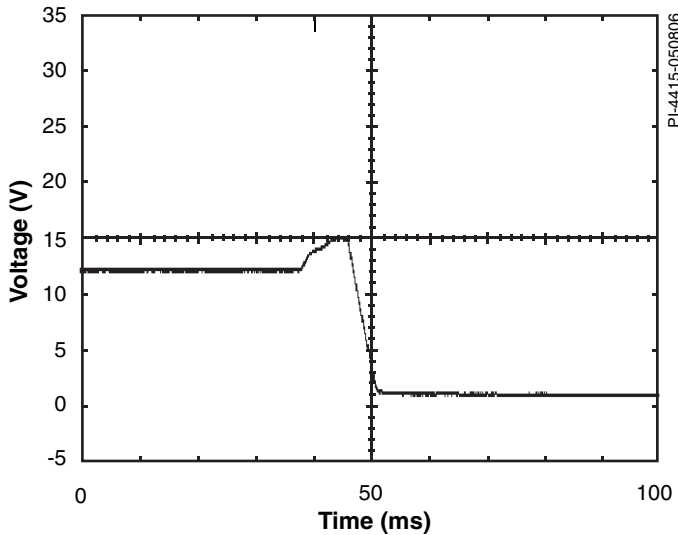

Figure 2. Worst-Case Open Loop Output Overvoltage (85 VAC, Full Load).

- To prevent an increase in no-load consumption or false OVP triggering, VR3 should be selected to conduct only when the output voltage is outside the normal regulation range. Resistor R4 prevents excessive current from flowing into the BP/M pin.
- Fast recovery glass-passivated diodes were selected for D1 and D3 to reduce low frequency conducted EMI. Fast diodes such as FR107 are also suitable.

Transformer Parameters

Core Material	EE20 N67 or equivalent, gapped for $A_{L,G}$ of 203 nH/t ²
Bobbin	5+5 pin, Horizontal
Winding Details	Shield: 24T, 28 AWG Primary: 62T, 31 AWG Bias: 5T, 4 × 28 AWG 12 V: 7T, 23 AWG T.I.W.
Winding Order (pin numbers)	3 mm tape margin, Shield (1-NC), tape, Primary (3-1), tape, Bias (5-4), tape, 12 V (10-9), tape
Inductance	Primary: 790 μ H, \pm 7% Leakage: 30 μ H (maximum)
Primary Resonant Frequency	650 kHz (minimum)

Table 1. Transformer Parameters. (AWG = American Wire Gauge, TIW = Triple Insulated Wire, NC = No Connection)

Power Integrations
5245 Hellyer Avenue
San Jose, CA 95138, USA.
Main: +1 408-414-9200
Customer Service
Phone: +1-408-414-9665
Fax: +1-408-414-9765
Email: usasales@powerint.com

On the Web
www.powerint.com

Power Integrations reserves the right to make changes to its products at any time to improve reliability or manufacturability. Power Integrations does not assume any liability arising from the use of any device or circuit described herein. POWER INTEGRATIONS MAKES NO WARRANTY HEREIN AND SPECIFICALLY DISCLAIMS ALL WARRANTIES INCLUDING, WITHOUT LIMITATION, THE IMPLIED WARRANTIES OF MERCHANTABILITY, FITNESS FOR A PARTICULAR PURPOSE, AND NON-INFRINGEMENT OF THIRD PARTY RIGHTS. The products and applications illustrated herein (transformer construction and circuits external to the products) may be covered by one or more U.S. and foreign patents or potentially by pending U.S. and foreign patent applications assigned to Power Integrations. A complete list of Power Integrations' patents may be found at www.powerint.com. Power Integrations grants its customers a license under certain patent rights as set forth at <http://www.powerint.com/ip.htm>.

The PI logo, TOPSwitch, TinySwitch, LinkSwitch, DPA-Switch, PeakSwitch, EcoSmart, Clampless, E-Shield, Filterfuse, StackFET, PI Expert and PI FACTS are trademarks of Power Integrations, Inc. Other trademarks are property of their respective companies. ©2006, Power Integrations, Inc.