

DI-115 Design Idea

TinySwitch®-PK

Wide Range DVD Player Multiple Output Power Supply with Peak Power Capability

Application	Device	Power Output	Input Voltage	Output Voltage	Topology
DVD Player	TNY376PN	7.5 W, 13 W Peak	85 - 265 VAC	3.3 V, 5 V, 12 V, -12 V	Flyback

Design Highlights

- Multiple output power supply
 - Excellent cross regulation
 - Two outputs sum-regulated
- Highly energy efficient
 - 0.6 W output power for 1 W input available
 - Low no-load power consumption (<150 mW at 230 VAC)
 - Meets CEC/ENERGY STAR 2008 requirements for active mode efficiency (77.7% vs. 68.1% requirement)
 - Meets CISPR-22/EN55022B conducted EMI limits >10 dB μ V margin
- Auto-restart withstands shorted output condition indefinitely

Operation

The TinySwitch-PK multiple output power supply shown in Figure 1 provides 7.5 W of continuous output power and 13 W of peak power. Typical applications include DVD players or set-top boxes where a multiple output flyback supply is required.

Diodes D1, D2, D3, and D4 and capacitors C1 and C4 rectify and smooth the AC input. Capacitors C1, C2, C8 and choke L1 provide differential as well as common-mode EMI filtering.

Capacitor C8 is optional for designs that do not require EMI to be measured with the output return connected to Earth ground.

The controller in U4 receives feedback from the secondary through optocoupler U2, and, based on that feedback, it enables or disables the switching of its integrated MOSFET to maintain output regulation. Portions of both the 3.3 V and the 5 V outputs are fed into the shunt regulator (U3), which controls the current through the LED in U2. A proportional current is then pulled out of the EN/UV pin. Switching cycles are skipped once the EN/UV disable threshold current (90 μ A) is exceeded. When the current out of the EN/UV pin falls below the disable threshold, switching cycles are re-enabled. The disable threshold is modulated to reduce group pulsing and ensure evenly spaced current pulses, thereby improving output ripple and efficiency. Under continuous power operating conditions, the TinySwitch-PK operates at 132 kHz. A unique peak mode feature boosts the current limit level by 30% and doubles the switching frequency to 264 kHz under peak load conditions.

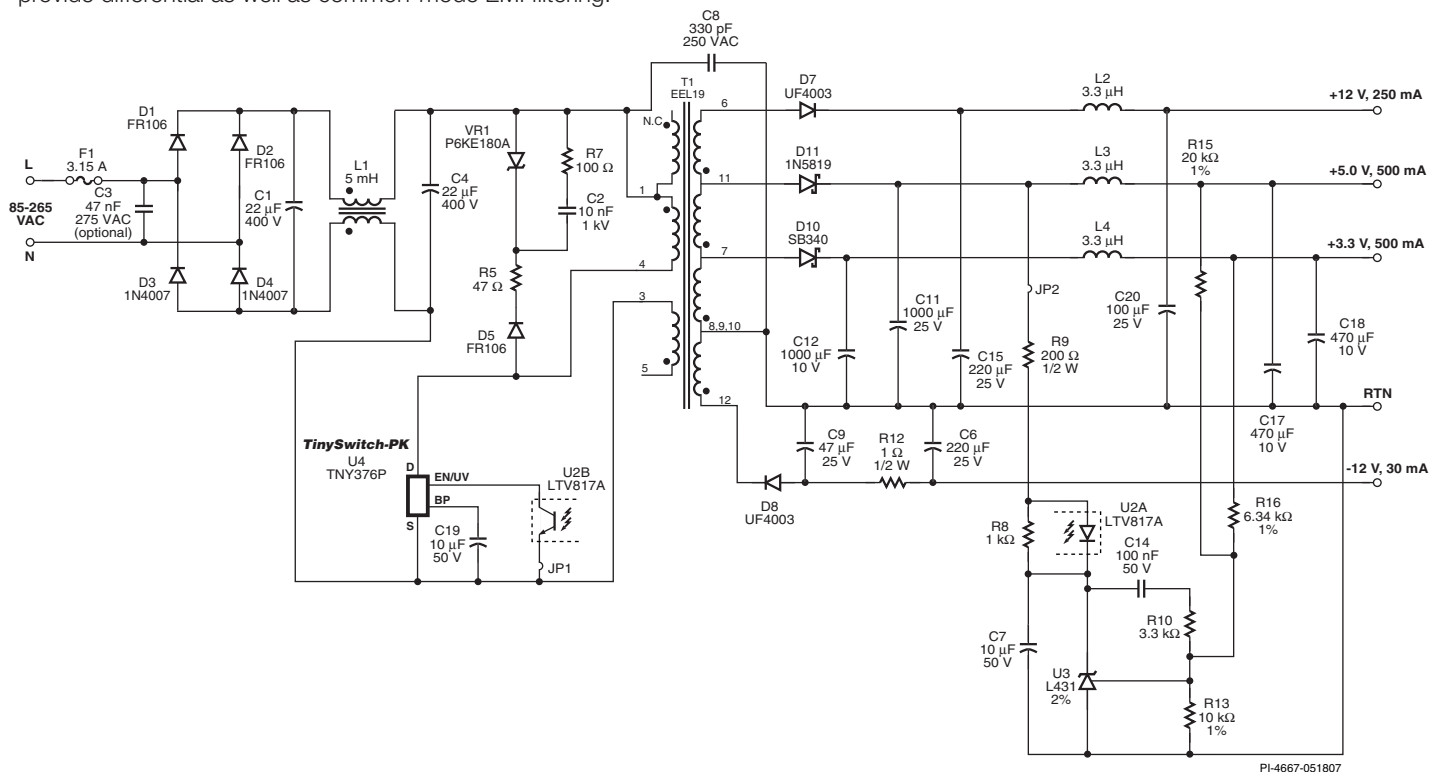

Figure 1. Schematic of a Universal Input, and Multiple-Output DVD Player Power Supply.

Good cross-regulation on 5 V and 3.3 V outputs is achieved by minimizing secondary leakage through the use of foil windings and by sum regulating (obtaining feedback from both outputs).

Key Design Points

- Components D5, R7, and C2 form an RCD clamp circuit, absorbing leakage inductance energy during normal operation. This energy is partly recovered when C2 resonates with the transformer primary inductance and couples into the secondary side. Resistors R5 and R7 damp this resonant ring and improve EMI. Zener VR1 clamps the voltage to a safe level.
- “Soft-finish” capacitor C7 is optional and prevents overshoot during startup.
- To route currents away from U4 during common-mode surges, the Y1 capacitor C8 is connected between secondary return and the DC bus.
- Due to 264 kHz switching frequency, the clamp diode (D5) should be selected with $t_{rr} \leq 500$ ns.
- Two fast diodes are used in the input bridge (D1 and D2) to reduce conducted EMI below 500 kHz.
- Open frame design, no external heatsink required.

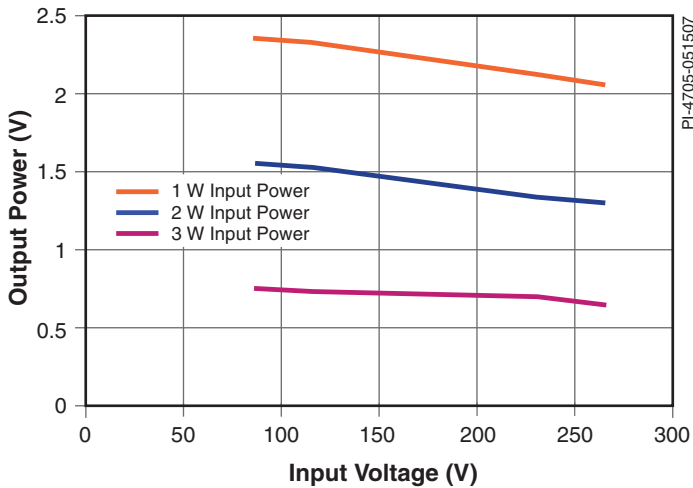

Figure 2. Available Standby Power at 1 W, 2 W and 3 W Input Power.

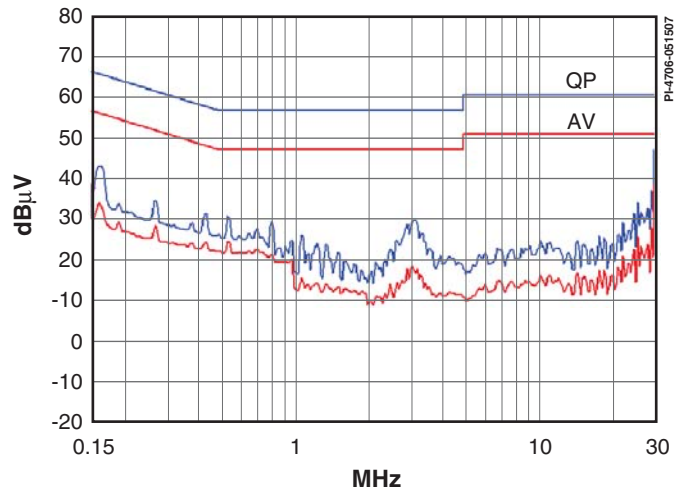

Figure 3. Conducted EMI at 230 VAC with Output Grounded (CISPR-22 Limit Lines Shown).

Transformer Parameters

Core Material	EEL19, NC-2H or equivalent, gapped for ALG of 150 nH/t ²
Bobbin	EEL19, 12 pin, Horizontal
Winding Details	3 mm margins on both sides of bobbin to meet safety Shield: 34T × 1, AWG28, tape Primary: 47T × 1, AWG29, tape Shield: 6T × 4, AWG29, 3 layers, tape 3.3 V: 2T, Foil 0.52 mm thickness 5 V: 1T, Foil 0.52 mm thickness, tape 12 V: 4T × 2, AWG26, tape -12 V: 7T × 2, AWG26, 2 layers tape
Winding Order	Shield (1-NC), Primary (1-4), Shield (3-5), 3.3 V (7-8,9,10), 5 V (7-11), 12 V (6-11), -12 V (8,9, 10-12)
Primary Inductance	813 µH, ±12%
Primary Resonant	300 kHz (minimum)
Leakage Inductance	30 µH (maximum)

Table 1. Transformer Parameters. (NC = No Connection, TIW = Triple Insulated Wire).

Power Integrations
5245 Hellyer Avenue
San Jose, CA 95138, USA.
Main: +1 408-414-9200
Customer Service
Phone: +1-408-414-9665
Fax: +1-408-414-9765
Email: usasales@powerint.com

On the Web
www.powerint.com

Power Integrations reserves the right to make changes to its products at any time to improve reliability or manufacturability. Power Integrations does not assume any liability arising from the use of any device or circuit described herein. POWER INTEGRATIONS MAKES NO WARRANTY HEREIN AND SPECIFICALLY DISCLAIMS ALL WARRANTIES INCLUDING, WITHOUT LIMITATION, THE IMPLIED WARRANTIES OF MERCHANTABILITY, FITNESS FOR A PARTICULAR PURPOSE, AND NON-INFRINGEMENT OF THIRD PARTY RIGHTS. The products and applications illustrated herein (transformer construction and circuits external to the products) may be covered by one or more U.S. and foreign patents or potentially by pending U.S. and foreign patent applications assigned to Power Integrations. A complete list of Power Integrations' patents may be found at www.powerint.com. Power Integrations grants its customers a license under certain patent rights as set forth at <http://www.powerint.com/ip.htm>.

The PI logo, TOPSwitch, TinySwitch, LinkSwitch, DPA-Switch, PeakSwitch, EcoSmart, Clampless, E-Shield, Filterfuse, StackFET, PI Expert and PI FACTS are trademarks of Power Integrations, Inc. Other trademarks are property of their respective companies.
©2007, Power Integrations, Inc.