

TinySwitch-III[®]

5 W, High Efficiency Charger for Portable Audio Players

Application	Device	Power Output	Input Voltage	Output Voltage	Topology
Charger	TNY274PN	5 W	85-265 VAC	5 V	Flyback

Design Highlights

- High Efficiency (>70% at Full load)
- Meets CEC/ENERGY STAR 2008 requirements for active mode efficiency (71.5% vs 64.5% requirement)
- Low input power at no-load (<230 mW at 230 VAC)
- Temperature compensated, low voltage drop, constant current (CC) sense.
- Meets CISPR-22/EN55022 B conducted EMI limits without a Y-capacitor

Operation

The *TinySwitch-III* Flyback power supply shown in Figure 1 generates a single isolated DC output voltage from an 85 VAC to 265 VAC input voltage range. The power supply output is 5 V, 1 A (5 W) constant-voltage/constant-current (CV/CC). Typical applications may include portable audio players, digital cameras, or other products where a compact, lightweight AC wall charger is needed.

Diodes D1, D2, D3, and D4, together with capacitors C1 and C2, rectify and smooth the AC input voltage.

Differential EMI filtering is provided by C1, C2, L1, and L2. The integrated frequency jitter feature of U1, along with transformer *E-Shield* techniques, allows such simple EMI filtering to comply with EN55022B, even without a Y-capacitor across the primary to secondary isolation barrier (see Figure 3). A bias winding supply is created by D6 and C5 to reduce no-load power consumption by feeding the IC supply current into the BP pin via R3.

The primary clamp (D5, R2, C4, and R1) limits the maximum peak drain voltage to less than the 700 V BV_{DSS} rating of the internal MOSFET. Resistor R2 reduces high-frequency leakage inductance ringing and thereby reduces EMI.

The output is regulated using optocoupler feedback. During CV operation, VR1 sets the reference voltage and drives the optocoupler. Transistors Q1 to Q3 and resistors R7 to R11 form the constant current regulation circuit. Once the voltage drop across R7 and R8 exceeds 0.35 V, Q1 turns on, turning on Q3 and thereby driving U2A and providing constant current control. The close proximity of Q2 and U2A provides temperature compensation of the CC circuit. *TinySwitch-III* allows this simple CC sensing scheme to be used while still meeting active-mode efficiency requirements.

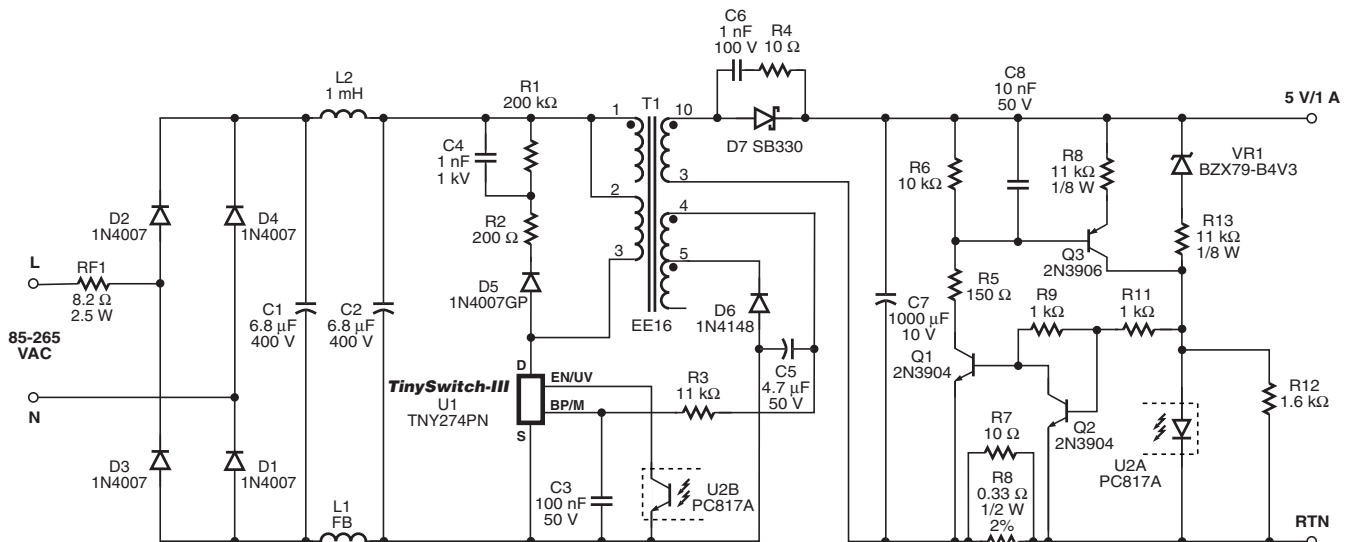

Figure 1. Schematic of a 5 V, 1 A Charger for Portable Audio Player Applications.

PI-4651-041807

The four source pins on one side of the DIP8 (P) package allow for a simple heatsink to be used. Figure 2 shows the active mode efficiency of the power supply plotted against load.

Key Design Points

- Verify that the maximum drain voltage is <650 V at high line and maximum overload condition. Adjust the values of R1 and C4 as necessary. However, avoid making the clamp circuit too large (i.e., low value of R1 and high value of C4), as this will increase the no-load power consumption.
- Use a slow blocking diode D5 with a 200 Ω series resistor. Use only a Glass Passivated (GP) diode type to ensure a reverse recovery time of 2 μ s or less. If a GP diode is unavailable, a fast diode such as FR107 may be used instead. These diode selections recycle some of the clamp energy, reducing power loss.
- Select the value of R3 for minimum no-load power consumption.
- Bias components D6, C5, and R3 are optional and if removed result in a no-load power consumption of <500 mW

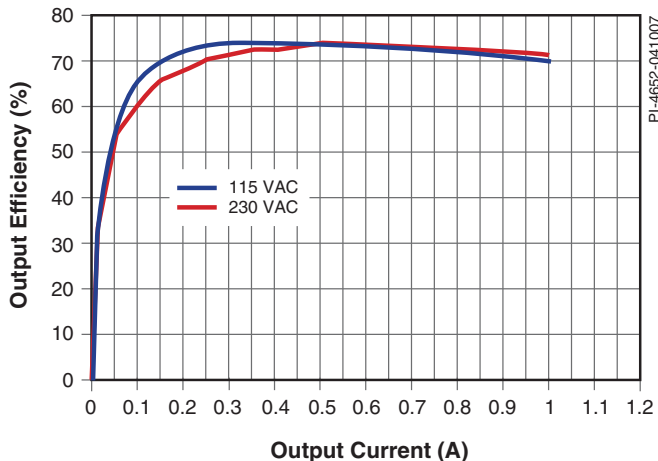

Figure 2. Efficiency vs. Load Current.

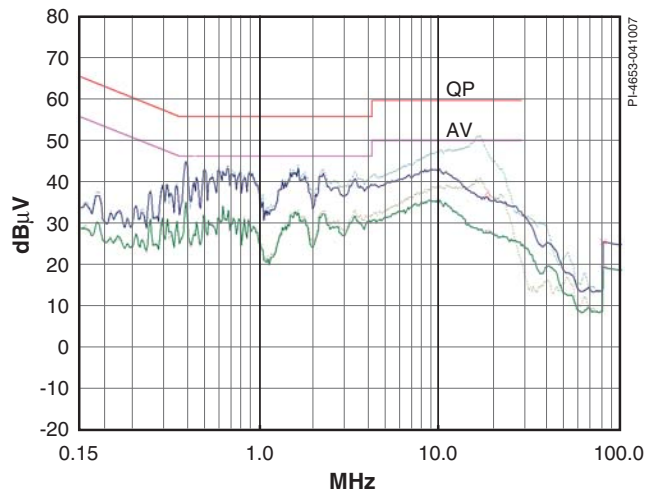

Figure 3. Conducted EMI Scan to EN55022B Limits. Darker Traces With Output RTN Connected to Artificial Hand, Lighter Traces With Output RTN Connected to Earth Ground.

TRANSFORMER PARAMETERS	
Core Material	EE16 Nippon Ceramic NC-2H A_{LG} of 174 nH/t ²
Bobbin	EE16, 10 pin (Ying Chin YC1607 or equivalent)
Winding Details	Bias/Shield: 20T \times 2, AWG 34, tape Primary: 80T \times 1, AWG 34, 2 layers, tape Shield: 1.5T Foil, 0.06 mm thick Secondary: 6T \times 2, AWG 26, TIW
Winding Order (pin numbers)	Bias (4-5), tape Primary (3-2,1), tape Shield (1-NC), tape 12 V (10-8), tape
Primary Inductance	2.52 mH \pm 12%
Primary Resonant Frequency	500 kHz (minimum)
Leakage Inductance	70 μ H (maximum)

Table 1. Transformer Parameters.

TIW = Triple Insulated Wire, NC = No Connect, FL = Flying Lead

For the latest updates, visit www.powerint.com

Power Integrations reserves the right to make changes to its products at any time to improve reliability or manufacturability. Power Integrations does not assume any liability arising from the use of any device or circuit described herein. POWER INTEGRATIONS MAKES NO WARRANTY HEREIN AND SPECIFICALLY DISCLAIMS ALL WARRANTIES INCLUDING, WITHOUT LIMITATION, THE IMPLIED WARRANTIES OF MERCHANTABILITY, FITNESS FOR A PARTICULAR PURPOSE, AND NON-INFRINGEMENT OF THIRD PARTY RIGHTS. The products and applications illustrated herein (transformer construction and circuits external to the products) may be covered by one or more U.S. and foreign patents or potentially by pending U.S. and foreign patent applications assigned to Power Integrations. A complete list of Power Integrations' patents may be found at www.powerint.com. Power Integrations grants its customers a license under certain patent rights as set forth at <http://www.powerint.com/ip.htm>.

The PI logo, TOPSwitch, TinySwitch, LinkSwitch, DPA-Switch, PeakSwitch, EcoSmart, Clampless, E-Shield, Filterfuse, StackFET, PI Expert and PI FACTS are trademarks of Power Integrations, Inc. Other trademarks are property of their respective companies. ©2007, Power Integrations, Inc.

Power Integrations
5245 Hellyer Avenue
San Jose, CA 95138
Phone: 1-408-414-9200
Apps: 1-408-414-9660
Apps Fax: 1-408-414-9760

For a complete listing of worldwide sales offices, please visit www.powerint.com