



Design Example Report

Title	<i>26W Multiple Output DC/DC Converter using DPA424R</i>
Specification	Input: 38 - 58VDC Output: 6.5V/0.5A, 8.2V/1.7A, 12.5V/1.3A, -5V/-30mA
Application	Telecom
Author	Power Integrations Applications Department
Document Number	DER-31
Date	March 30, 2004
Revision	1.0

Summary and Features

- Forward converter topology for low output ripple and minimum output capacitance
- Highly integrated DC/DC chip minimizes external component count and cost
- Tight cross-regulation through coupled output inductor
- <30W input power at nominal load

The products and applications illustrated herein (including circuits external to the products and transformer construction) may be covered by one or more U.S. and foreign patents or potentially by pending U.S. and foreign patent applications assigned to Power Integrations. A complete list of Power Integrations' patents may be found at www.powerint.com.

Table Of Contents

1	Introduction	3
2	Power Supply Specification.....	4
3	Schematic	5
3.1	Circuit Description	6
3.1.1	Architecture.....	6
3.1.2	Primary side.....	6
3.1.3	Magnetics	6
3.1.4	Secondary side	6
3.2	Bill of Materials.....	8
4	Magnetics Specification	9
4.1	Transformer Design	9
4.1.1	Electrical Specifications	10
4.1.2	Materials	10
4.1.3	Transformer Build Diagram.....	10
4.1.4	Transformer Construction	11
4.2	Coupled Inductor Design	12
4.2.1	Electrical Specifications	12
4.2.2	Materials	12
4.2.3	Inductor Build Diagram	13
4.2.4	Inductor Construction.....	13
5	Measurements	14
5.1	Operating Efficiency	14
5.2	Input Power at Nominal Load.....	14
5.3	Key Component Temperature Rises.....	15
5.4	Line Regulation	15
5.5	Cross-Regulation	16
6	Operating Waveforms	17
6.1	DPA-Switch Drain-Source Voltage and Drain Current	17
6.2	Output Voltage Start-up Profiles at Nominal Load	19
6.3	Transient Load Response	20
6.4	Output Ripple Voltage at Nominal Load.....	21
6.5	Input Current Ripple.....	22
7	Output Diode Current.....	23
8	Revision History	24

Important Notes:

Although this board is designed to satisfy safety isolation requirements, the engineering prototype has not been agency approved. Therefore, all testing should be performed using an isolated source to provide power to the prototype board.

Design Reports contain a power supply design specification, schematic, bill of materials, and transformer documentation. Performance data and typical operation characteristics are included. Typically only a single prototype has been built.



1 Introduction

This report describes a design proposal for a 26W (33W Peak) multiple output forward converter using DPA-Switch. Included are a schematic, bill of materials and detailed design information for the transformer and coupled inductor. In addition, a full set of performance measurements have been taken based on the prototype converter shown in Figure 1 below.

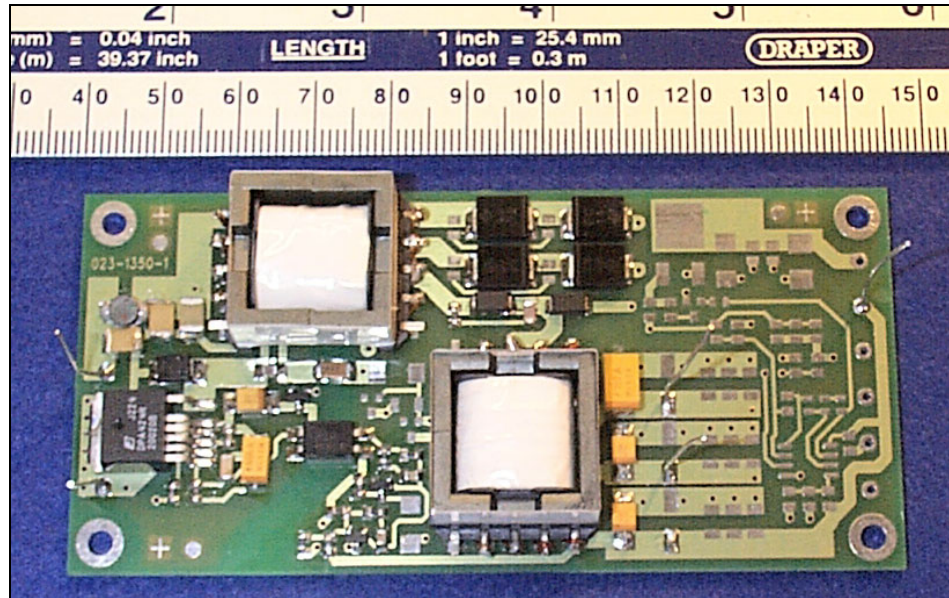

Figure 1 - Prototype DC/DC Converter (Scale in cm)



2 Power Supply Specification

Description	Symbol	Min	Typ	Max	Units	Comment
Input Voltage	V_{IN}	38	48	58	V_{DC}	±20% Variation
Output Output Voltage 1	V_{OUT1}	5.85	6.5	7.15	V	± 10%
Output Ripple Voltage 1	$V_{RIPPLE1}$			25	mV	20 MHz Bandwidth
Output Current 1	I_{OUT1}	0	0.5	0.5	A	
Output Voltage 2	V_{OUT2}	7.4	8.2	9.0	V	±10%
Output Ripple Voltage 2	$V_{RIPPLE2}$			25	mV	20 MHz Bandwidth
Output Current 2	I_{OUT2}	0.85	1.2	1.65	A	
Output Voltage 3	V_{OUT3}	11.9	12.5	13.2	V	±5%
Output Ripple Voltage 3	$V_{RIPPLE3}$			25	mV	20 MHz Bandwidth
Output Current 3	I_{OUT3}	0.25	1	1.3	A	
Output Voltage 4	V_{OUT4}	-4	-5	-8	V	
Output Ripple Voltage 4	$V_{RIPPLE4}$			25	mV	20 MHz Bandwidth
Output Current 4	I_{OUT4}	-30	-30	-30	mA	
Total Output Power Continuous Output Power	P_{OUT}		26	33.2	W	
Efficiency	η	80			%	
Environmental Conducted EMI						Meets CISPR22B / EN55022B
Ambient Temperature	T_{AMB}	0		70	°C	Free convection, Sea level

Table 1 - Power Supply Specification



3 Schematic

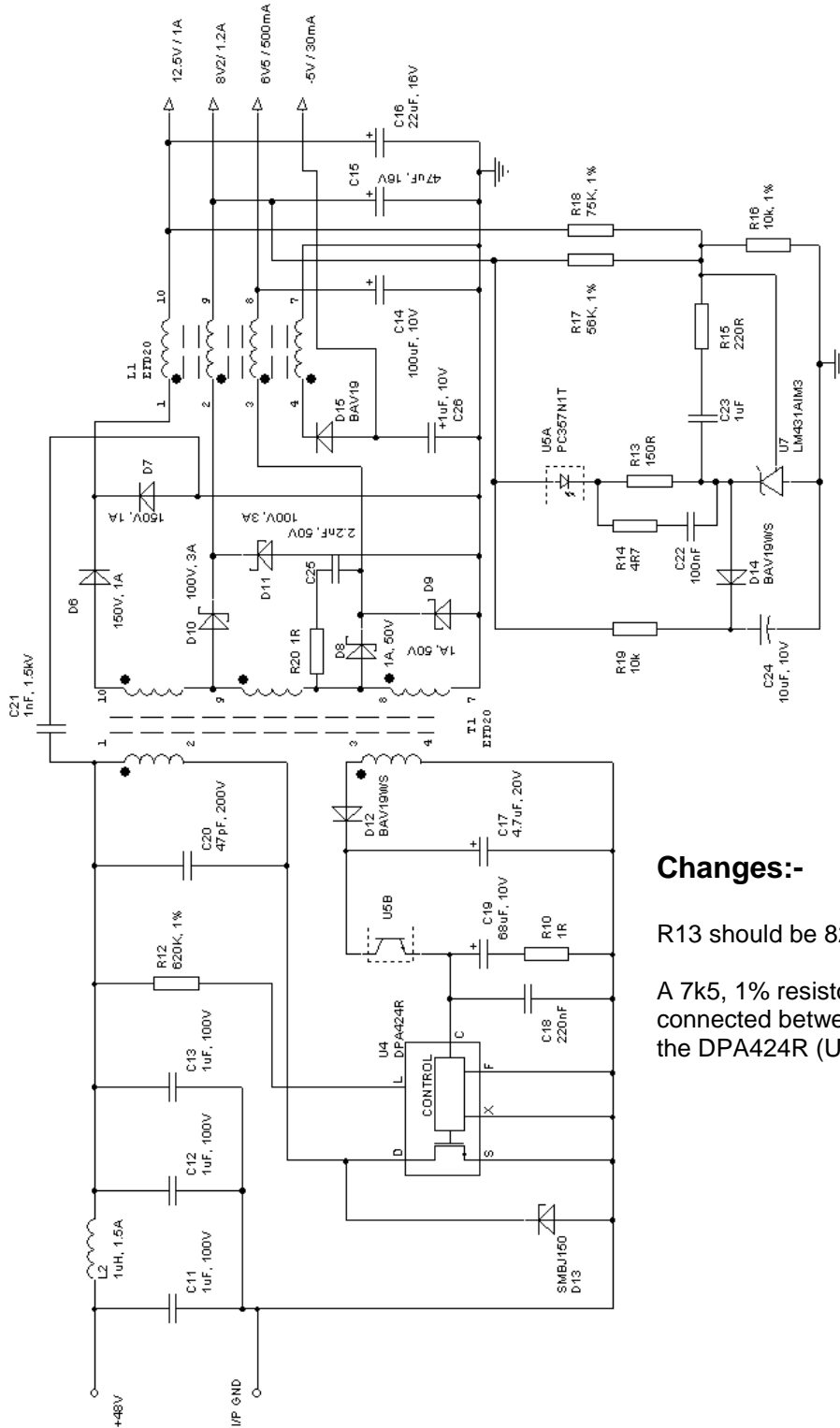

Changes:-

R13 should be 820R

A 7k5, 1% resistor should be connected between the x and s-pin on the DPA424R (U4)

Figure 2 - Schematic of EFD20 based design



3.1 *Circuit Description*

3.1.1 Architecture

This DC/DC converter has been realized using a multiple output forward converter. This topology was used in order to minimize the amount of tantalum capacitors required to meet stringent output noise and ripple requirements.

3.1.2 Primary side

On the primary side, the DPA-Switch incorporates:-

- Internal current sensing avoiding the use of an external shunt resistor
- Auto-restart to protect the system against output short circuits
- Under-voltage and over-voltage protection
- Soft Start
- Built in hysteretic thermal shutdown
- 400kHz high accuracy oscillator

Input current filtering is provided by C11, C12 C13 and L2. These components are designed only to minimize input current ripple and not designed to filter conducted EMI and further filtering may be required.

Transformer reset is achieved using a resonant reset scheme. When the DPA-Switch turns off, magnetising energy flows from the magnetising inductance into the secondary RC network of R20 and C25. This energy is then sent to the output during the next turn on period of the DPASwitch. This technique avoids the use of a demagnetisation winding.

3.1.3 Magnetics

Due to a relatively high operating temperature requirement of 70°C, the output coupled inductor and transformer were both realised using EFD20 cores. This gives low peak to peak flux density variations and low operating current density in the windings. To avoid circulating currents, the turns ratios between the windings on the inductor have been chosen to reflect the turns ratios on the secondary of the transformer. The output capacitance on each rail has been chosen to give a LC corner frequency of around 5kHz. This ensures low voltage ripple on the outputs.

3.1.4 Secondary side

The requirement for 80% operating efficiency allows the use of standard rectification on the secondary side to give minimum cost. Due to the relatively limited input voltage range of 48V, $\pm 20\%$, power to the feedback network and the DPA-switch is derived from a forward connected winding on the main transformer. C18 provides local decoupling for



the DPASwitch whilst C19 and R10 form a local feedback compensation network. D13 provides a hard clamp voltage to prevent overvoltage on the DPA-switch during load transients or input voltage transients. It is not normally active since the reset scheme recaptures most of the magnetisation energy. The secondary side feedback takes information from both the 8V5 and the 12V5 outputs since these two have the tightest tolerance requirements. A precision LM431AIM3 2.5V reference has been used with local compensation provided by C23, R15, R13, R14 and C22. D14, R19 and C24 provide a 'soft-finish' network that guarantees no output voltage overshoot.

The -5V rail is driven by a flyback connected winding on the output inductor. The minimum output power level ensures the current in the output inductor is continuous and therefore good regulation on the -5V rail can be achieved.

C21 provides a route for common-mode currents to return from the secondary to the primary, minimising common-mode noise.



3.2 Bill of Materials

Component Reference	Quantity	Value / Description
C11,C12,C13	3	1uF, 100V
C14	1	100uF, 10V
C15	1	47uF, 16V
C16	1	22uF, 16V
C17	1	4.7uF, 20V
C18	1	220nF
C19	1	68uF, 10V
C20	1	47pF, 200V
C21	1	1nF, 1.5kV
C22	1	100nF
C23	1	1uF
C24	1	10uF, 10V
C25	1	2.2nF, 50V
C26	1	1uF, 10V
D7,D6	2	150V, 1A
D8,D9	2	1A, 50V
D11,D10	2	100V, 3A
D14,D12, D15	3	BAV19WS
D13	1	SMBJ150
L1	1	EFD20 Custom Coupled Inductor
L2	1	1uH, 1.5A
R20,R10	2	1R
R12	1	620K, 1%
R13	1	150R
R14	1	4R7
R15	1	220R
R16	1	10k, 1%
R17	1	56K, 1%
R18	1	75K, 1%
R19	1	10k
T1	1	EFD20 Custom Transformer
U4	1	DPA424R
U5	1	PC357N1T
U7	1	LM431AIM3

Total of 42 components.

Figure 3 - BOM for EFD20 based Design



4 Magnetics Specification

4.1 Transformer Design

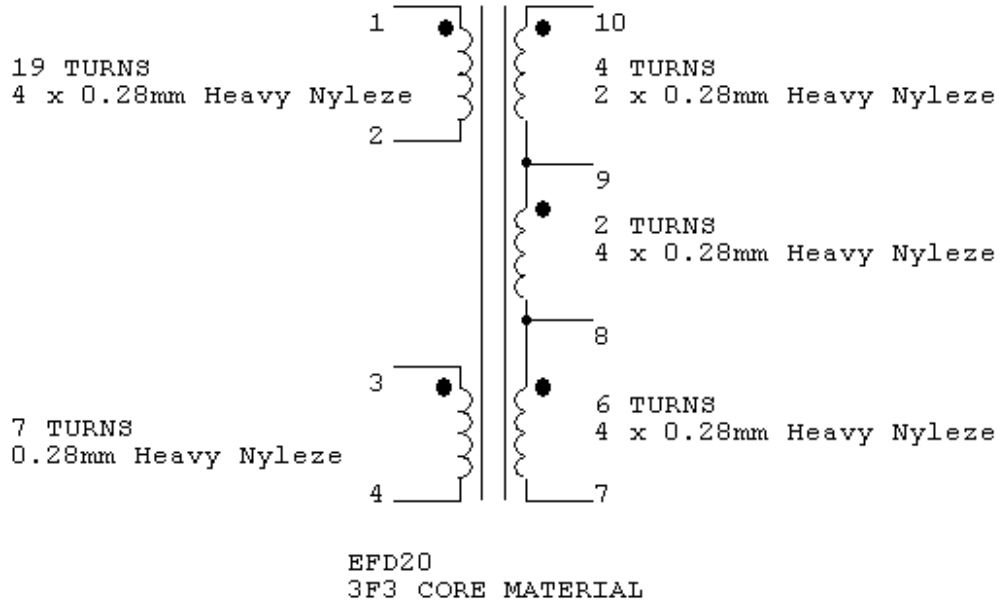

Figure 4 - Transformer Electrical Diagram

The transformer should be built using a 10 pin surface mount EDF20 bobbin as shown in Figure 5. Pin numbers in Figure 4 should be taken anti-clockwise from pin 1 as viewed from above the transformer.

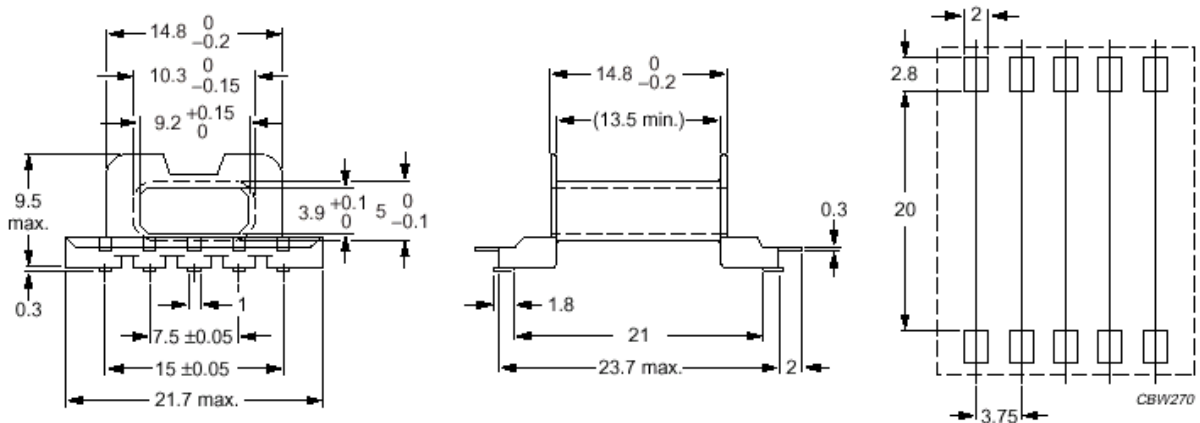

Figure 5 - 10 pin surface mount EFD20 bobbin



4.1.1 Electrical Specifications

Electrical Strength	1 minute, 60 Hz, from Pins 1-2 to Pins 7-10	500 VAC
Primary Inductance	Pins 1-2 with all other windings open, 10 kHz measurement frequency	408μH +/-10%
Resonant Frequency	Pins 1-2 with all other windings open	3MHz minimum
Primary Leakage Inductance	Pins 1-2 with Pins 7-10 shorted together, 10 kHz measurement frequency	1μH maximum

4.1.2 Materials

Item	Description
[1]	Core: EFD20 in 3F3 material - ungapped. Ferroxcube number EFD20-3F3
[2]	Bobbin: 10 Pin Ferroxcube bobbin number CPHS-EFD20-1S-10P
[3]	Magnet Wire: # 29 AWG (0.28 mm) Double Nyleze
[4]	Tape: 3M 1298 Polyester Film. 13mm wide by 0.1 mm thick
[5]	Varnish

4.1.3 Transformer Build Diagram

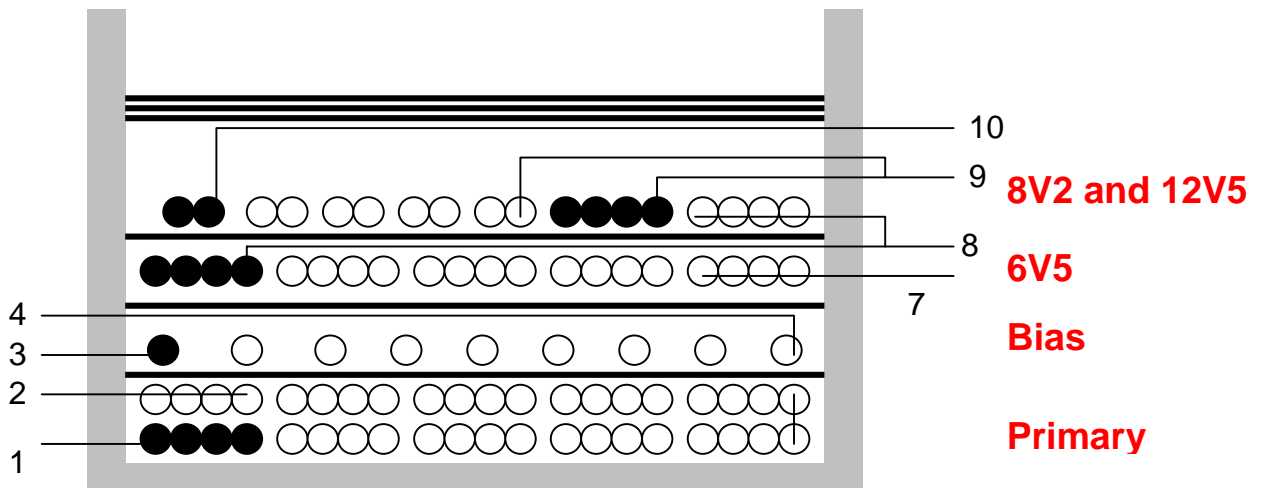

Figure 6 - Transformer Build Diagram

4.1.4 Transformer Construction

Primary	Start at Pin 1. Wind 19 turns of 4 parallel strands of item [3] from left to right. Fill two complete winding layers. Finish on Pin 2.
Insulation	1 layer of tape [4] to hold winding in place.
Bias Winding	Start at Pin 3. Wind 7 turns of item [3] from left to right. Wind uniformly, in a single layer, across entire width of bobbin. Finish on Pin 4.
Insulation	1 layer of tape [4] to hold winding in place.
6V5 Winding	Start at Pin 7. Wind 6 turns of four parallel strands of item [3] from right to left as a ribbon. Fill one complete layer. Finish on Pin 8.
9V6 and 12V Windings	Start at Pin 8. Wind 2 turns of four parallel strands of item [3] from right to left. Terminate on Pin 9. Continue winding with two parallel strands of item [3] from right to left. Finish on Pin 10. These two windings should occupy one single uniform layer.
Insulation	3 Layers of tape [4] for insulation.
Final Assembly	Assemble and secure core halves. Impregnate uniformly (dip varnish) [5] and bake.



4.2 Coupled Inductor Design

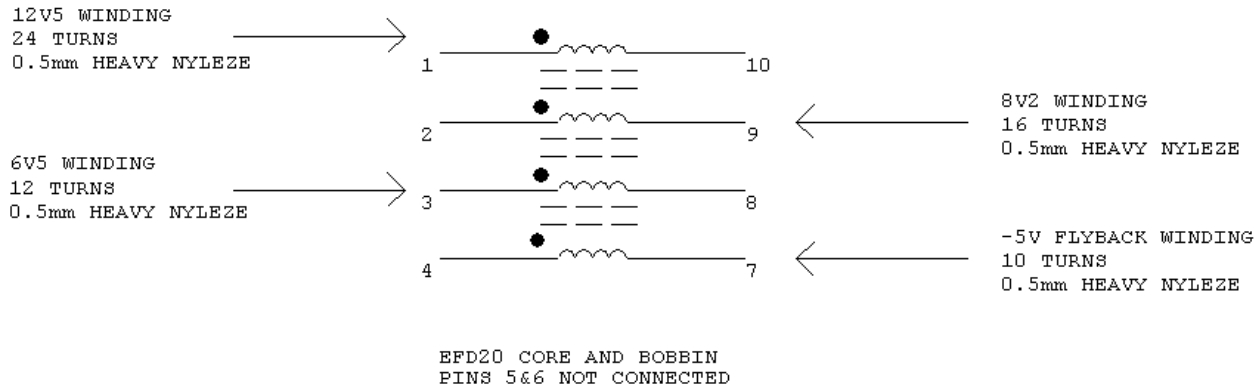

Figure 7 - Coupled Inductor Electrical Diagram

Pin numbering is the same as used for the transformer. See section 4.1 for details.

4.2.1 Electrical Specifications

Electrical Strength	Functional Only	
6V5 Winding Inductance	Pins 1-10 with all other windings open, 10 kHz measurement frequency	14.4μH +/-10%
9V6 Winding Inductance	Pins 2-9 with all other windings open, 10 kHz measurement frequency	25.6μH +/-10%
12V Winding Inductance	Pins 3-8 with all other windings open, 10 kHz measurement frequency	57.6μH +/-10%
-5V Flyback Winding Inductance	Pins 4-7 with all other windings open, 10 kHz measurement frequency	10μH +/-10%
Resonant Frequency	Pins 4-7 with all other windings open	3MHz minimum

4.2.2 Materials

Item	Description
[1]	Core: EFD20 in 3F3 material gapped for 100nH/T ² (~0.25mm center leg gap) Ferroxcube number EFD20-3F3
[2]	Bobbin: 10 Pin Ferroxcube bobbin number CPHS-EFD20-1S-10P
[3]	Magnet Wire: # 24 AWG (0.5 mm) Double Nyleze
[4]	Tape: 3M 1298 Polyester Film. 13.5mm wide by 0.1 mm thick
[5]	Varnish



4.2.3 Inductor Build Diagram

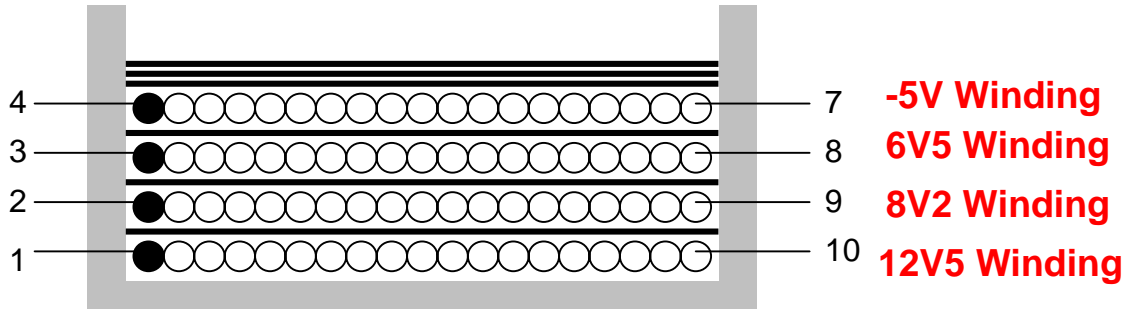

Figure 8 – Inductor Build Diagram

4.2.4 Inductor Construction

12V5 Rail Winding	Start at Pin 1. Wind 24 turns of item [3] from left to right. Finish on Pin 10. Wind uniformly in a single layer.
Insulation	1 layer of tape [4] to hold winding in place.
8V2 Rail Winding	Start at Pin 2. Wind 16 turns of item [3] from left to right in a single layer. Finish on Pin 9.
Insulation	1 Layers of tape [4] for insulation.
6V5 Rail Winding	Start at Pin 3. Wind 12 turns of item [3] from left to right. Finish on Pin 8.
Insulation	1 Layers of tape [4] for insulation.
-5V Rail Flyback Winding	Start at Pin 4. Wind 10 turns of item [3] from left to right. Finish on Pin 7.
Insulation	3 Layers of tape [4] for insulation.
Final Assembly	Assemble and secure core halves. Impregnate uniformly (dip varnish) [5] and bake.

5 Measurements

All measurements were taken in a lab ambient temperature of 25°C with the PCB mounted horizontally in zero airflow.

5.1 Operating Efficiency

Figure 9 shows the converter operating efficiency at the typical power level and peak power levels as defined in Table 1.

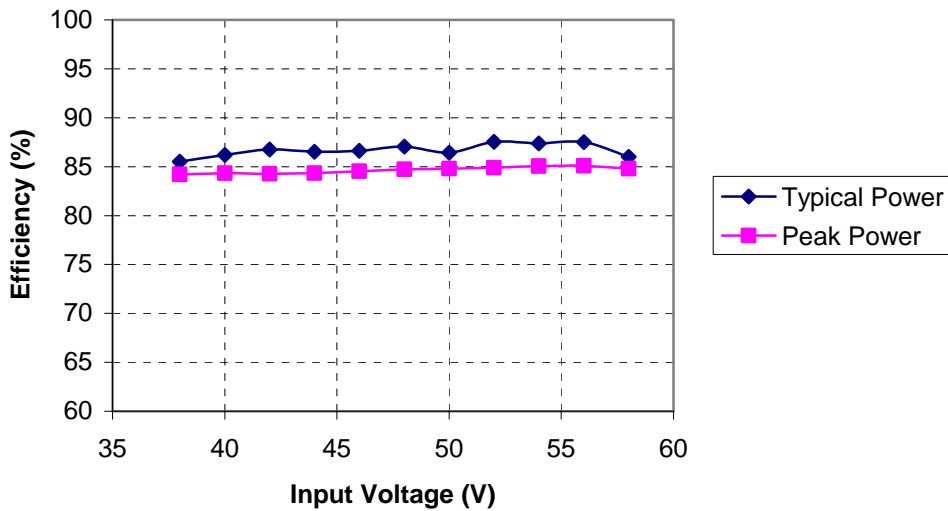

Figure 9 - Conversion Efficiency Variation with Input Voltage

5.2 Input Power at Nominal Load

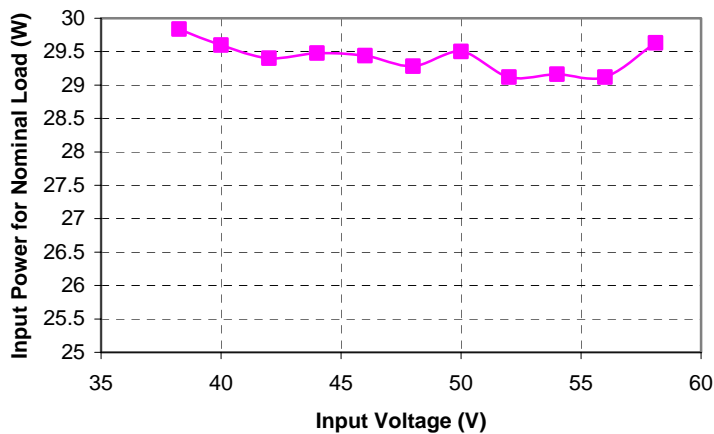

Figure 10 - Input Power at Nominal Load



5.3 Key Component Temperature Rises

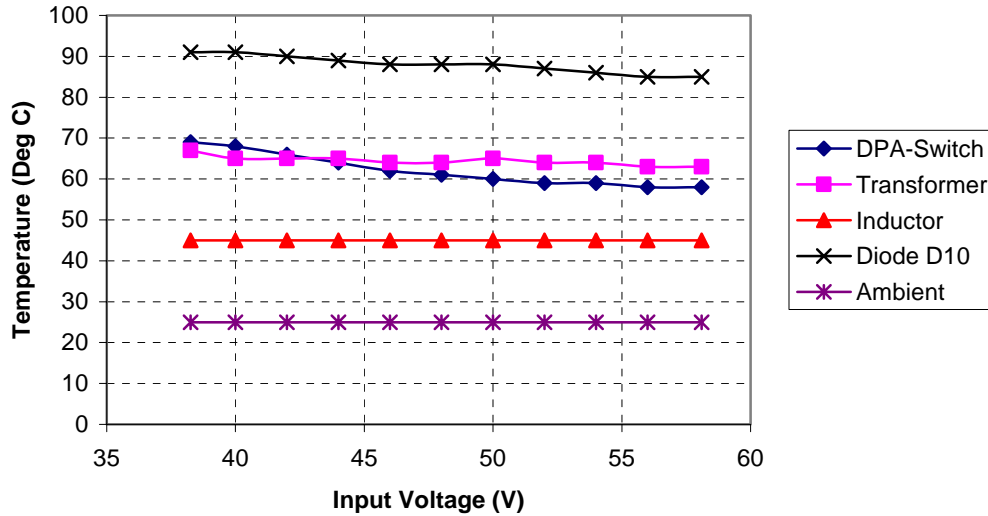

Figure 11 - Key component temperature rise under nominal load conditions

The thermal measurements show that the output diodes will need more heatsinking to allow safe operation in a 70°C ambient. Alternatively, lower drop diodes will give lower loss and will therefore run cooler.

5.4 Line Regulation

Under the nominal power conditions, the output voltages were measured as a function of input voltage. Figure 12 shows the resulting line regulation, expressed as a percentage of nominal output voltage (0% is zero error)

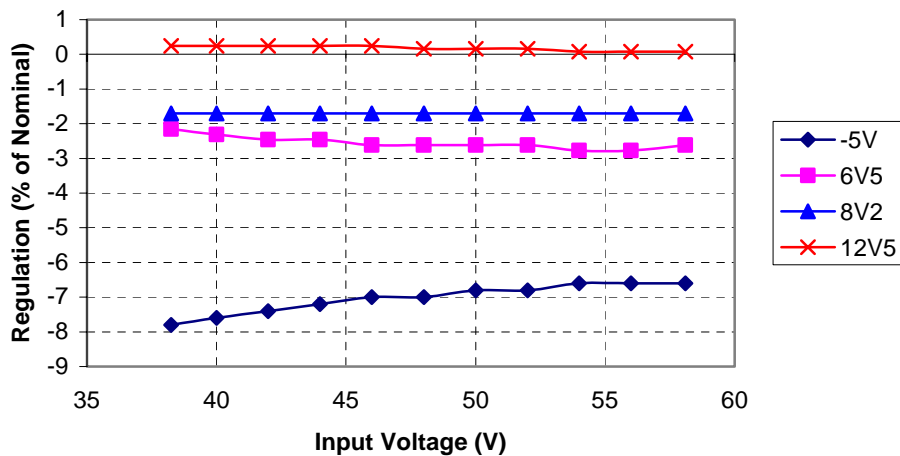

Figure 12 - Line Regulation under Nominal Load



5.5 Cross-Regulation

The multiple output design used here will exhibit output voltages which vary as a function of the currents on all the output rails. This section quantifies this variation using the minimum/maximum loads specified in Table 1. The 6V5 rail is required to run down to zero current and still maintain regulation so a small preload will be required. Measurements show that this preload should be 40mA in order to meet the 7.15V maximum requirement on the 6V5 rail.

Measurements were taken at nominal 48V input and with all combinations of minimum to maximum load. The -5V rail load was kept constant at -30mA.

6V5 - 8V2 -12V5	-5V	6V5	8V2	12V5
XXX	-4.61	7.15	8.05	12.59
XXM	-4.64	7.15	8.12	12.44
XMX	-4.61	7.15	7.96	12.69
XMM	-4.67	7.13	8.03	12.54
MXX	-4.61	6.24	8.05	12.59
MXM	-4.65	6.31	8.11	12.45
MMX	-4.63	6.29	7.96	12.68
MMM	-4.65	6.38	8.03	12.54

Notes :-

Load on 6V5 is 10mA to meet 7.15V requirement
 Load on 6V5 is 23mA to meet 7.15V requirement
 Load on 6V5 is 14mA to meet 7.15V requirement
 Load on 6V5 is 37mA to meet 7.15V requirement

X is Minimum Load
 M is Maximum Load

Rail Voltage (V)	Minimum Load (A)	Maximum Load (A)
6.5	0	0.5
8.2	0.85	1.65
12.5	0.25	1.3
-5	-0.03	-0.03

Table 2- Cross-Regulation Measurements at Nominal Load¹

These measurements give the following cross regulation performance: -

-5V Rail	-8% to -6%	
6V5 Rail	-4% to +10%	(With 40mA minimum pre-load)
8V2 Rail	-3% to -1%	
12V5 Rail	-0.5% to +1.5%	

¹ Based on these measurements, a 130Ω preload resistor should be used on the 6V5 rail to meet cross-regulation requirements. This resistor should be 0.5W rated.



6 Operating Waveforms

6.1 DPA-Switch Drain-Source Voltage and Drain Current

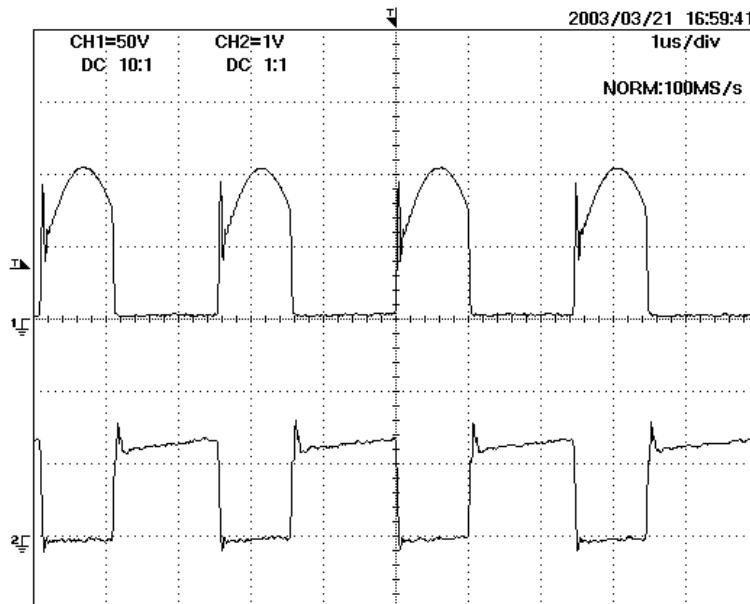

Figure 13 - 38Vdc, Nominal Load, Drain-Source Voltage (Upper 50V/div) and Drain Current (Lower 1A/div)

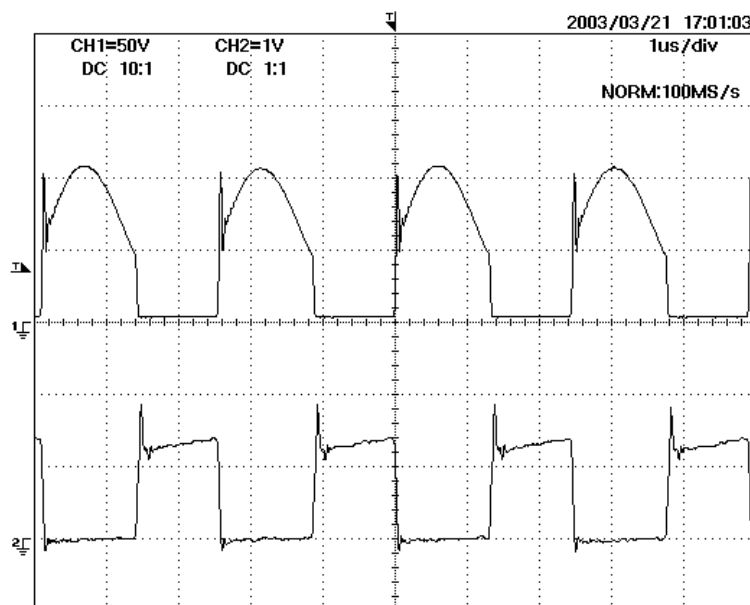

Figure 14 - 48Vdc, Nominal Load, Drain-Source Voltage (Upper 50V/div) and Drain Current (Lower 1A/div)



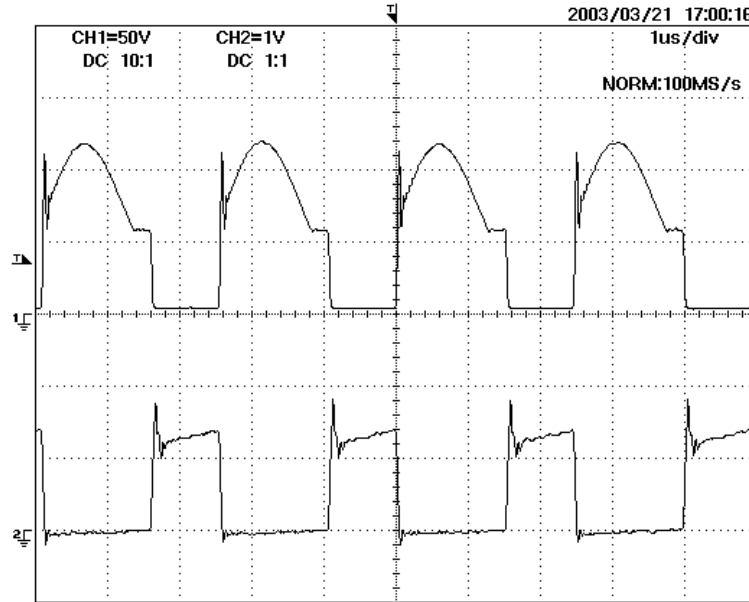

Figure 15 - 58Vdc, Nominal Load, Drain-Source Voltage (Upper 50V/div) and Drain Current (Lower 1A/div)



6.2 Output Voltage Start-up Profiles at Nominal Load

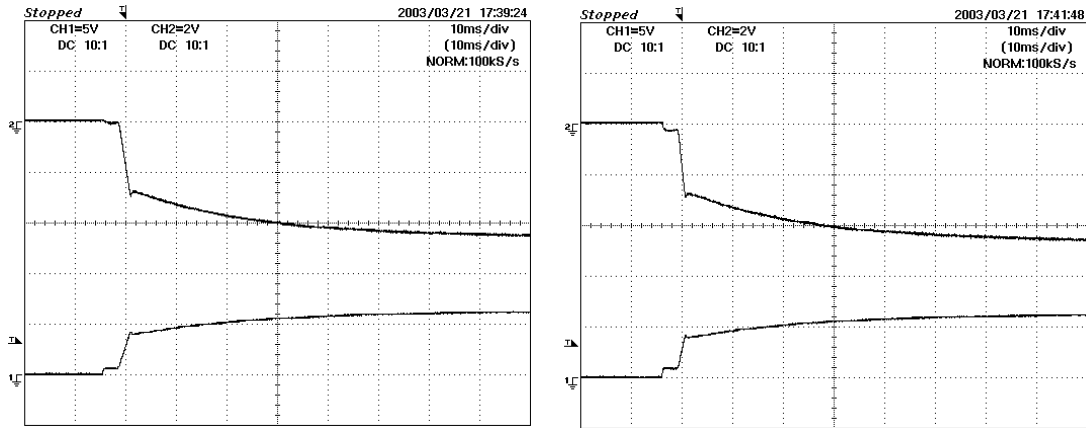

Figure 16 - 6V5 (Lower at 5V/div) and -5V (Upper 2V/div). Left hand graph is 38V input and right hand graph is 58V input

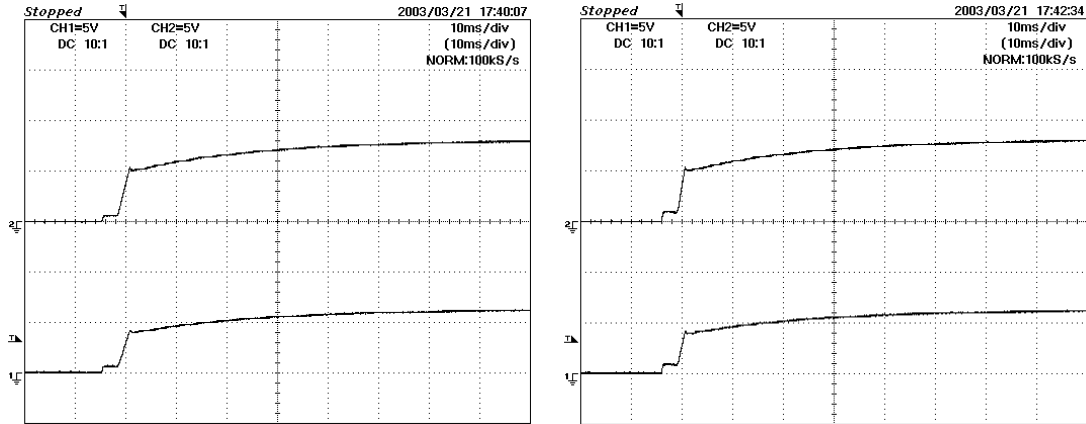

Figure 17 - 6V5 (Lower at 5V/div) and 8V2 (Upper 5V/div). Left hand graph is 38V input and right hand graph is 58V input

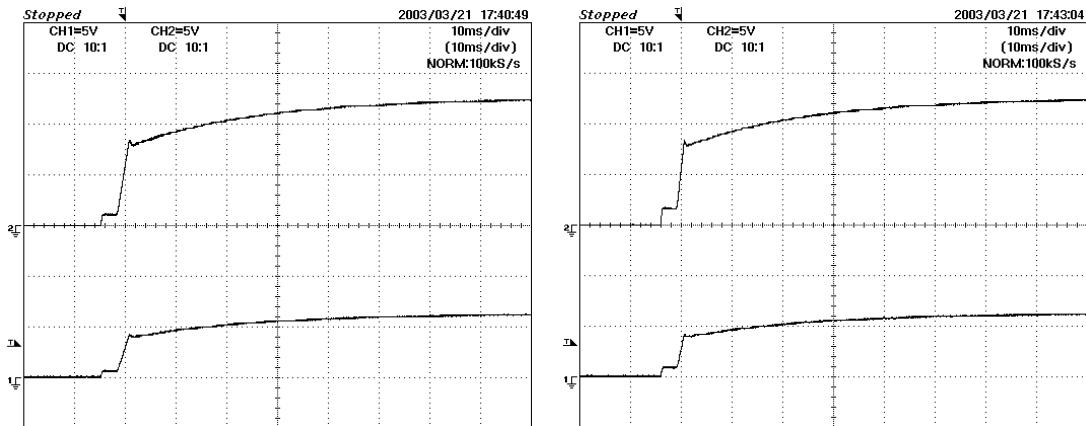

Figure 18 - 6V5 (Lower at 5V/div) and 12V5 (Upper 5V/div). Left hand graph is 38V input and right hand graph is 58V input



6.3 Transient Load Response

The converter was set to nominal load and the load on the 8V2 rail changed from its nominal level of 1.2A to its peak level of 1.65A. The figures below show the transient response of the 8V2 rail to this load change. The responses show a well damped behavior.

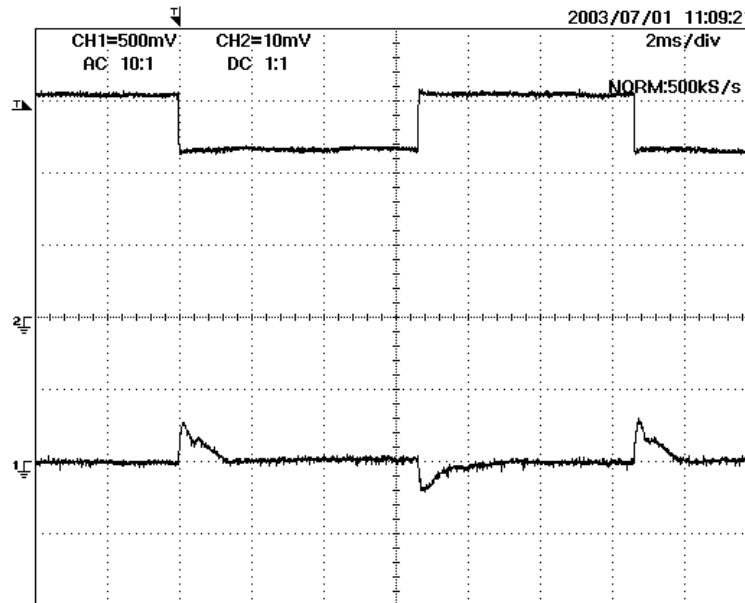

Figure 19 – 38V input. 8V2 rail load transient response (Upper – 8V2 rail current at 0.5A/div, Lower – AC coupled 8V2 rail voltage at 500mV/div)



Figure 20 – 58V input. 8V2 rail load transient response (Upper – 8V2 rail current at 0.5A/div, Lower – AC coupled 8V2 rail voltage at 500mV/div)



6.4 Output Ripple Voltage at Nominal Load

Under nominal load conditions, the output ripple voltage was measured. The figures below show the results.

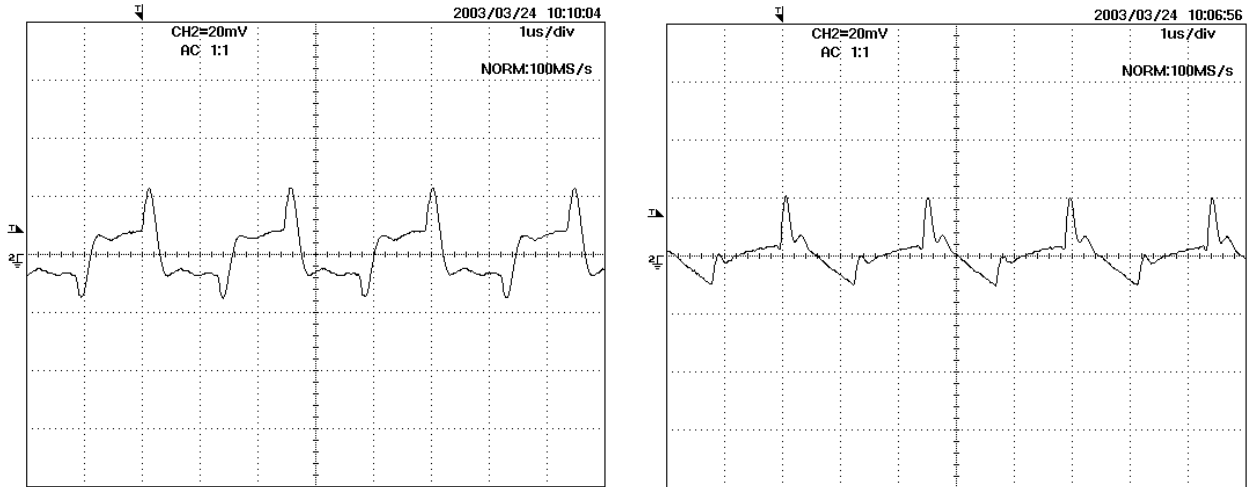

Figure 21 – Both traces AC coupled at 20mV/div. 48V input. Left hand graph is -5V rail and right hand graph is 6V5 rail.

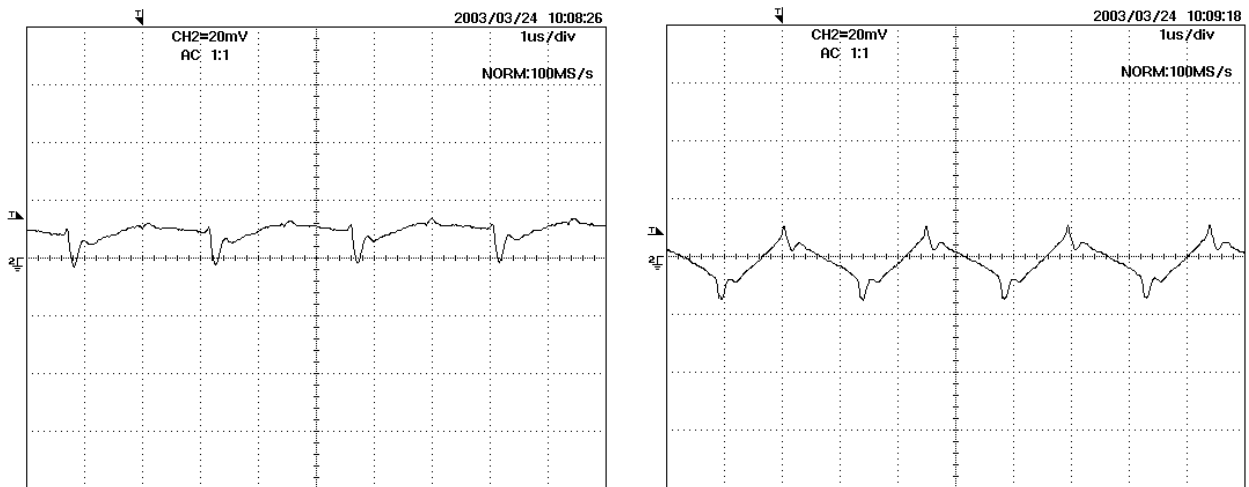

Figure 22 – Both traces AC coupled at 20mV/div. 48V input. Left hand graph is 8V2 rail and right hand graph is 12V5 rail.



6.5 Input Current Ripple

The converter input current ripple was measured at nominal power. The figures below show the measured levels at 38V and 58V respectively.

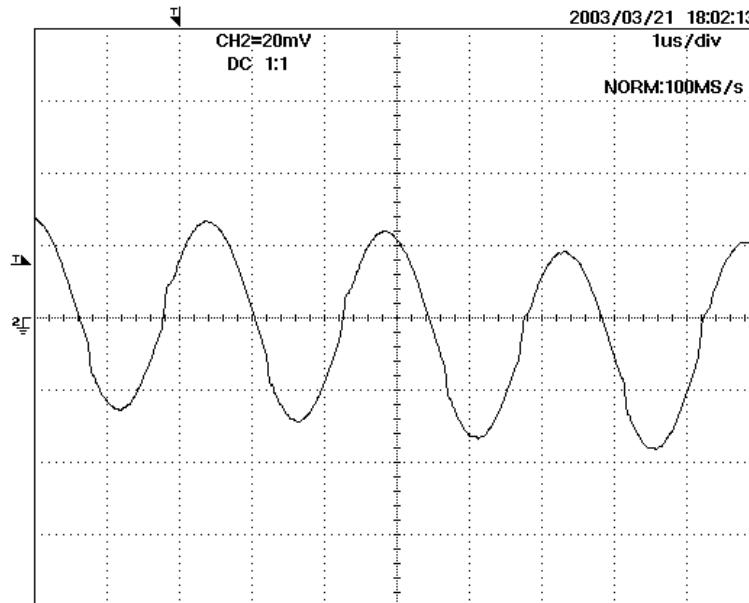

Figure 23 - Input Current Ripple at Nominal load and 38V input (20mA/div)

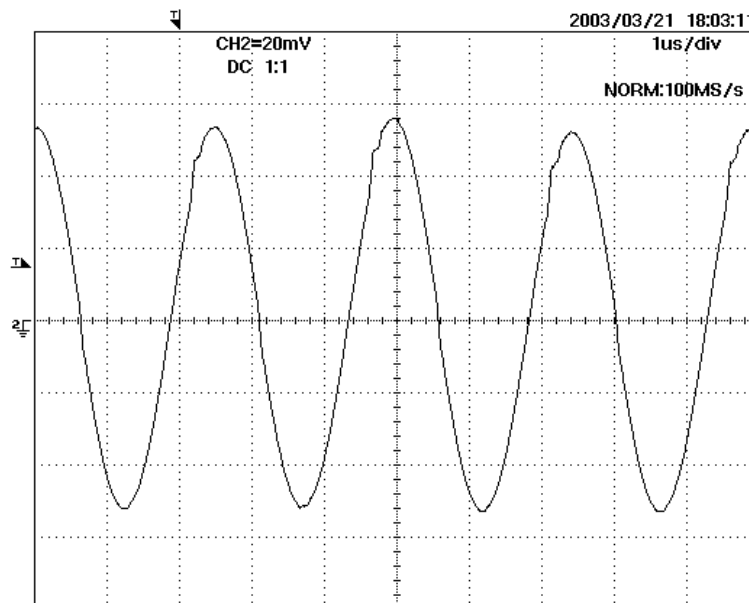

Figure 24 - Input Current Ripple at Nominal load and 58V input (20mA/div)



7 Output Diode Current

The current in diodes D6, D8, D10 were measured simultaneously to check the turns ratios between transformer secondaries and the coupled inductor windings, in addition to the voltage drop of diodes D6 to D10 didn't lead to high circulating currents. The figures below show the nature of these currents.

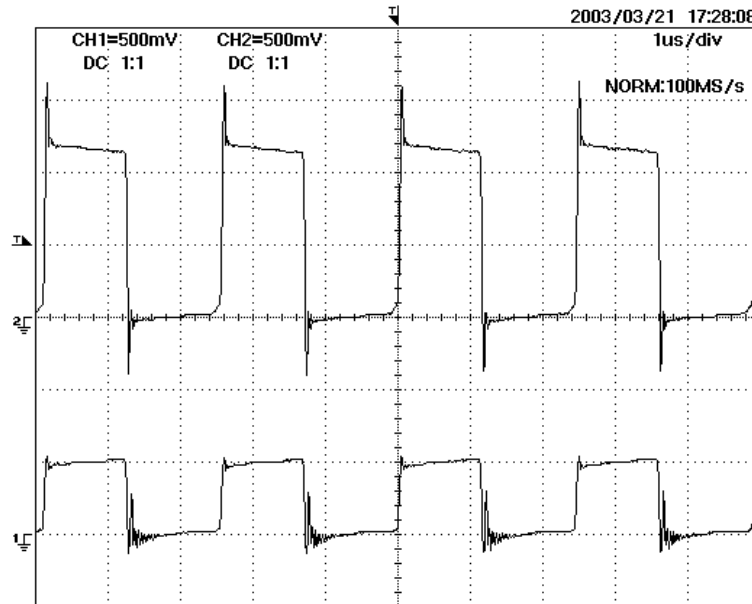

Figure 25 - Current in D8 (Lower at 0.5A/div) and D10 (Upper at 0.5A/div) at nominal load

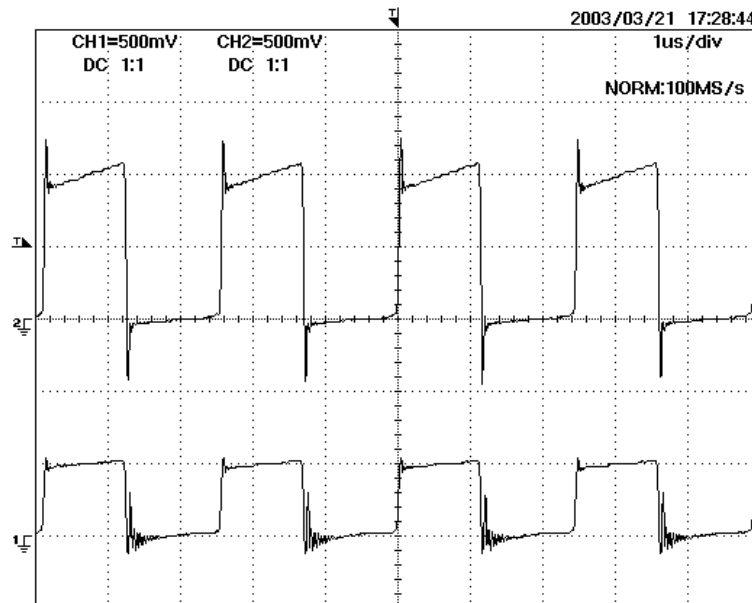

Figure 26 - Current in D8 (Lower at 0.5A/div) and D6 (Upper at 0.5A/div) at nominal load



8 Revision History

Date	Author	Revision	Description & changes	Reviewed
March 30, 2004	IM	1.0	Initial release	VC / AM



For the latest updates, visit our Web site: www.powerint.com

Power Integrations reserves the right to make changes to its products at any time to improve reliability or manufacturability. Power Integrations does not assume any liability arising from the use of any device or circuit described herein, nor does it convey any license under its patent rights or the rights of others.

The products and applications illustrated herein (including circuits external to the products and transformer construction) may be covered by one or more U.S. and foreign patents or potentially by pending U.S. and foreign patent applications assigned to Power Integrations. A complete list of Power Integrations' patents may be found at www.powerint.com.

The PI Logo, **TOPSwitch**, **TinySwitch**, **LinkSwitch**, and **EcoSmart** are registered trademarks of Power Integrations, Inc. **PI Expert** and **DPA-Switch** are trademarks of Power Integrations, Inc.
© Copyright 2003, Power Integrations, Inc.

**WORLD HEADQUARTERS
NORTH AMERICA - WEST**

Power Integrations, Inc.
5245 Hellyer Avenue
San Jose, CA 95138 USA.
Main: +1•408•414•9200
Customer Service:
Phone: +1•408•414•9665
Fax: +1•408•414•9765

**NORTH AMERICA - EAST
& SOUTH AMERICA**

Power Integrations, Inc.
Eastern Area Sales Office
1343 Canton Road, Suite C1
Marietta, GA 30066 USA
Phone: +1•770•424•5152
Fax: +1•770•424•6567

EUROPE & AFRICA

Power Integrations (Europe) Ltd.
Centennial Court
Easthampstead Road
Bracknell
Berkshire RG12 1YQ,
United Kingdom
Phone: +44•1344•462•301
Fax: +44•1344•311•732

TAIWAN

Power Integrations International
Holdings, Inc.
2F, #508, Chung Hsiao E. Rd.,
Sec. 5,
Taipei 105, Taiwan
Phone: +886•2•2727•1221
Fax: +886•2•2727•1223

CHINA

Power Integrations
International
Holdings, Inc.
Rm# 1705, Bao Hua Bldg.
1016 Hua Qiang Bei Lu
Shenzhen Guangdong,
518031
Phone: +86•755•367•5143
Fax: +86•755•377•9610

KOREA

Power Integrations
International
Holdings, Inc.
Rm# 402, Handuk Building,
649-4 Yeoksam-Dong,
Kangnam-Gu,
Seoul, Korea
Phone: +82•2•568•7520
Fax: +82•2•568•7474

JAPAN

Power Integrations, K.K.
Keihin-Temomono 1st Bldg.
12-20 Shin-Yokohama 2-
Chome,
Kohoku-ku, Yokohama-shi,
Kanagawa 222, Japan
Phone: +81•45•471•1021
Fax: +81•45•471•3717

INDIA (Technical Support)

Innovatech
#1, 8th Main Road
Vasanthnagar
Bangalore, India 560052
Phone: +91•80•226•6023
Fax: +91•80•228•9727

APPLICATIONS HOTLINE

World Wide +1•408•414•9660

APPLICATIONS FAX

World Wide +1•408•414•9760



Power Integrations, Inc.

Tel: +1 408 414 9660 Fax: +1 408 414 9760
www.powerint.com