



Design Example Report

Title	<i>13W Power Supply using TOP242P</i>
Specification	Input: 195 – 265 V _{AC} Output: 3.3V / 428mA, 2.5V / 215mA, 5V / 985mA, 6.6V / 668mA, 12V / 55mA
Application	Set Top Box
Author	Power Integrations Applications Department
Document Number	DER-23
Date	March 30, 2004
Revision	1.0

Summary and Features

This report describes a design for a multiple output power supply, such as required for a Set Top Box, featuring the following:

- Very low cost, minimal component count
- Dual pitched design allows cost optimization for 230V only or universal mains operation
- Meets conducted EMI (EN55022) with a hard ground on the power supply output
- High reliability through soft-start, short circuit and thermal shutdown detection

The products and applications illustrated herein (including circuits external to the products and transformer construction) may be covered by one or more U.S. and foreign patents or potentially by pending U.S. and foreign patent applications assigned to Power Integrations. A complete list of Power Integrations' patents may be found at www.powerint.com.

Table Of Contents

1	Introduction.....	4
2	Power Supply Specification.....	5
3	Schematic.....	6
4	Circuit Description	7
4.1	Input and EMI Filtering	7
4.2	TOPSwitch Primary	7
4.3	Secondary Side.....	8
4.4	Output Feedback.....	8
4.5	1V2 Linear Regulator	8
5	Bill Of Materials	9
6	PCB Layout	10
7	Transformer Specification.....	11
7.1	Electrical Diagram	11
7.2	Electrical Specifications.....	11
7.3	Materials.....	11
7.4	Transformer Build Diagram	12
7.5	Transformer Construction.....	12
8	Transformer Spreadsheets.....	13
8.1	230V Mains Design	13
8.2	Universal Mains Design.....	15
9	Prototype Performance	19
9.1	230V Prototype Performance Measurements	19
9.1.1	Efficiency.....	19
9.1.2	Line Regulation	20
9.1.3	Cross Regulation.....	21
9.1.4	Thermal Measurements	22
9.1.5	230V Prototype Waveform Measurements	23
9.1.6	Primary Side Start-up Waveforms.....	23
9.1.7	Conducted EMI Measurements.....	29
9.2	Universal Mains Prototype Performance Measurements	30
9.2.1	Efficiency.....	30
9.2.2	Line Regulation	31
9.2.3	Cross Regulation.....	32
9.2.4	Thermal Measurements	33
9.2.5	Universal Mains Prototype Waveform Measurements	34
9.2.6	Primary Side Start-up Waveforms.....	34
9.2.7	Conducted EMI Measurements.....	39
10	Appendix A – Tolerance of Linear Regulated Outputs.....	40
10.1	2V5 Linear Regulated Output.....	40
10.2	1V2 Discrete Linear Regulator	41
11	Revision History	43



Important Note:

Although this board is designed to satisfy safety isolation requirements, the engineering prototype has not been agency approved. Therefore, all testing should be performed using an isolation transformer to provide the AC input to the prototype board.

Design Reports contain a power supply design specification, schematic, bill of materials, and transformer documentation. Performance data and typical operation characteristics are included. Typically only a single prototype has been built.



1 Introduction

This document is a design proposal detailing a 13W power supply utilizing TOP242P. The supply has been cost optimized for 230V (195 – 265Vac) operation although changes required for full universal mains operation have been given. The most cost effective solution is the 230V design. Moving to a universal design will require the following changes:-

Change TOP242P to TOP243P

Change the bulk input capacitor from 15uF, 400V to 47uF, 400V.

This document contains the power supply specification, schematic, bill of materials, and transformer documentation. In addition, measurements have been included from the prototype shown in Figure 1 below.

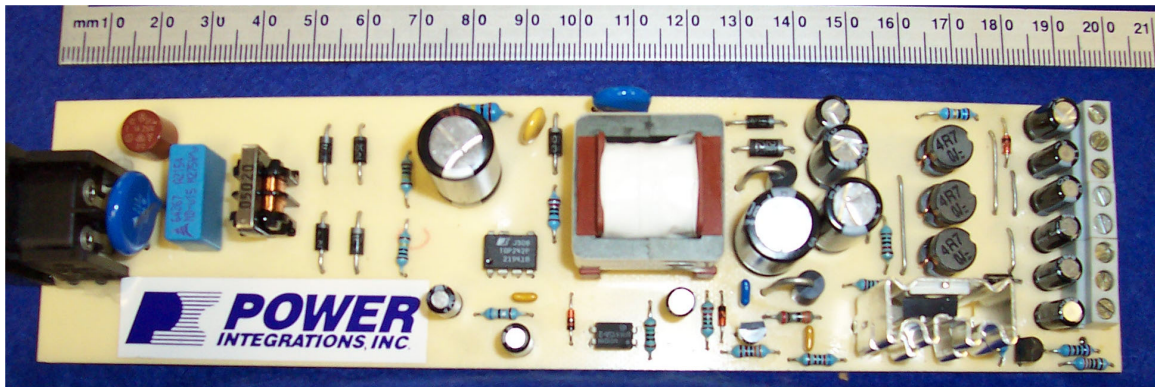

Figure 1 - Prototype Cable STB Power Supply (200mm x 50mm x 26mm)

2 Power Supply Specification

Description	Symbol	Min	Typ	Max	Units	Comment
Input						
Voltage	V_{IN}	195	230	265	VAC	2 Wire – no P.E.
Frequency	f_{LINE}	47	50	53	Hz	
Output						
Output Voltage 1	V_{OUT1}		1.2		V	$\pm 5\%$
Output Ripple Voltage 1	$V_{RIPPLE1}$		10		mV	20 MHz Bandwidth
Output Current 1	I_{OUT1}	35		759	mA	
Output Voltage 2	V_{OUT2}		2.5		V	$\pm 5\%$
Output Ripple Voltage 2	$V_{RIPPLE2}$				mV	20 MHz Bandwidth
Output Current 2	I_{OUT2}	30		215	mA	
Output Voltage 3	V_{OUT3}		3.3		V	$\pm 5\%$
Output Ripple Voltage 3	$V_{RIPPLE3}$		30		mV	20 MHz Bandwidth
Output Current 3	I_{OUT3}	152		428	mA	
Output Voltage 4	V_{OUT4}	4.85	5	5.25	V	
Output Ripple Voltage 4	$V_{RIPPLE4}$		50		mV	20 MHz Bandwidth
Output Current 4	I_{OUT4}	121		985	mA	
Output Voltage 5	V_{OUT5}		6.6		V	$\pm 10\%$
Output Ripple Voltage 5	$V_{RIPPLE5}$		50		mV	20 MHz Bandwidth
Output Current 5	I_{OUT5}	100		668	mA	
Output Voltage 5	V_{OUT5}		12		V	$\pm 10\%$
Output Ripple Voltage 5	$V_{RIPPLE5}$		50		mV	20 MHz Bandwidth
Output Current 5	I_{OUT5}	30		55	mA	
Total Output Power						
Continuous Output Power	P_{OUT}			12.9 ¹	W	
Efficiency	η		66 ²		%	Measured at P_{OUT} , 25 °C
Environmental						
Conducted EMI			Meets CISPR22B / EN55022B			
Safety			Designed to meet IEC950, UL1950 Class II			
Surge		4			kV	1.2/50 μ s surge, IEC 1000-4-5, Series Impedance: Differential Mode: 2 Ω Common Mode: 12 Ω
Surge		3			kV	100 kHz ring wave, 500 A short circuit current, differential and common mode
Ambient Temperature	T_{AMB}	0		50	°C	Free convection, sea level

Table 1 - Design Specifications

¹ The power supply has been designed to continuously deliver the maximum rail current for each rail in an ambient temperature of 50°C.

² This efficiency includes the loss due to the linear regulators for the 1V2 and 2V5 rails.



4 Circuit Description

The power supply is based on a standard multiple output flyback converter using the integrated features of **TOPSwitch-GX** to minimize component count and cost. The TOP242P used in this design integrates the following functionality:-

- Frequency jitter which reduces the QP and AV EMI levels by up to 10dB allowing for cheaper EMI filter components
- Soft-Start which prevents transformer saturation during start-up and after fault recovery. This increases long term reliability
- Line UV and OV detection to give additional differential surge withstand capability to increase reliability
- Regulation to zero load without pre-load due to very low minimum duty cycle capability
- Line feed forward which improves 100Hz ripple rejection
- Hysteretic thermal and short circuit protection to increase long term reliability
- DIP08 package which requires no additional heatsink to minimize BOM and manufacturing cost.

Since both 2V5 and 1V2 rails are difficult to produce directly from the main power transformer, the approach taken here is to use the 3V3 rail to drive the 2V5 rail via a diode drop and the 1V2 via a discrete linear regulator. Both these techniques will reduce the overall conversion efficiency and increase heat dissipation but are likely to be the lowest cost. To reflect the loading of the 1V2 and 2V5 rails, the current on the 3V3 rail was increased to 1.4A.

If an improvement in efficiency is required to minimize heat generation, DC/DC converters can be used to generate the 1V2 and 2V5 rails. One further design option would be to drive the 1V2 linear regulator from a lower voltage than the 3V3 by using an extra winding but this has not been implemented in this design.

4.1 Input and EMI Filtering

EMI filtering is provided by C1, L1 and C18. A toroidal style common-mode choke for L1 should be avoided since the tight coupling of a toroidal construction will reduce differential EMI filtering capability. The input stage also incorporates a mains fuse for safety and an MOV (R1) for enhanced differential surge protection. 4kV (EN61000-4-5:1995) surge can be met without R1 due to the over-voltage shutdown protection implemented by TOP243P. The MOV is used to give the maximum 6kV surge immunity protection.

4.2 TOPSwitch Primary

A bias winding is used on the primary side to provide power for the TOP242P and also to drive the feedback current into the control pin of the device. R4 and R5 implement the



over-voltage / under-voltage shutdown protection. The primary side clamp circuit uses an RCD network to limit the voltage spike due to the transformer leakage energy at the point when the **TOPSwitch** turns off. A 1N4007GP diode has been used here which has a specified reverse recovery time of 2 to 3 μ S. This diode allows some of the energy stored in the clamp capacitor to be recycled which helps to increase efficiency. It is important not to use a standard 1N4007 diode here since they have a reverse recovery time much longer than this.

4.3 Secondary Side

The 3V3 and 5V rails both use Schottky diodes to provide low voltage drop, which helps to maintain high conversion efficiency. A snubber network (R7 and C11) across D7 reduces diode ringing which will lower common-mode EMI levels. All rails generated from transformer windings utilize further LC post filtering to keep output ripple and noise levels within specification. The diode used to generate the 2.5V rail should be chosen for the correct voltage drop and dissipation capability. The 1.2V linear regulator will be included on the prototype PCB but it is recommended that this is placed closer to the main logic using this rail.

4.4 Output Feedback

Feedback is derived from the 3V3 and 5V rails to maintain 5% regulation on both. Each rail has a 50% influence on the feedback loop. The feedback reference is provided by a TL431 via an opto-isolator. D11, C17 and R10 form a soft finish network to provide a monotonic rise in output voltage at start-up and under fault recovery conditions.

4.5 1V2 Linear Regulator

The discrete linear regulator uses an N-channel MOSFET (Q3) driven by a bipolar transistor which is biased from the 12V winding output.



5 Bill Of Materials

	Component Reference	Quantity	Value / Description	Manufacturer
Capacitors	C1	1	100nF, X2	Philips
	C2	1	22uF, 400V	Panasonic
	C3	1	1nF, 400V	Panasonic
	C16,C4	2	100nF	Beyersschlag/Centralab
	C5	1	47uF, 16V	Panasonic
	C6	1	1uF, 50V	Panasonic
	C7	1	680uF, 35V	Rubycon
	C8	1	470uF, 35V	Rubycon
	C9	1	220uF, 35V	Rubycon
	C10,C12,C13,C14,C15,C19	6	100uF, 16V	Rubycon
	C11	1	4n7	Panasonic
	C17	1	10uF, 35V	Panasonic
	C18	1	2n2, Y1 Safety	Cera-Mite
	Diodes	D1,D2,D3,D4	4	1N4007
D5		1	1N4007GP	Vishay
D11,D6		2	1N4148	Vishay
D7		1	SB320	Vishay
D8		1	SB360	Vishay
D9		1	UG2B	Vishay
D10		1	UF4001	Vishay
D12		1	1N4005	Vishay
D16		1	BZX79C-12	Vishay
Fuse	F1	1	1A, 230V	Wickman
Magnetics	L1	1	20mH, 0.2A	Panasonic
	L8,L9,L10	3	4.7uH, 2A	Toko
	T1	1	Custom EF25	
Transistors	Q1	1	BC184L	Motorola
	Q3	1	FQP33N10	Fairchild
Resistors	R1	1	275V	Panasonic
	R2	1	100k, 1W	Generic
	R3	1	100R	Generic
	R4,R5	2	1M	Generic
	R6	1	6R8	Generic
	R7	1	3R3	Generic
	R8	1	150R	Generic
	R9	1	330R	Generic
	R10	1	10k	Generic
	R11	1	10k, 1%	Generic
	R12	1	6k2, 1%	Generic
	R13	1	20k, 1%	Generic
	R15,R14	2	3k, 1%	Generic
	R16	1	16R	Generic
R17	1	3k3	Generic	
IC's	U1	1	TOP242P/G	Power Integrations
	U3	1	PC817	Liteon
	U4	1	TL431	Texas Instruments
Misc		1	Heatsink for Q3	

Total of 61 components

Table 2 - Bill of Materials



6 PCB Layout

A single sided construction was used for the PCB to give lowest cost. Figure 3 and Figure 4 below show the copper layout (viewed from above) and the component placements.

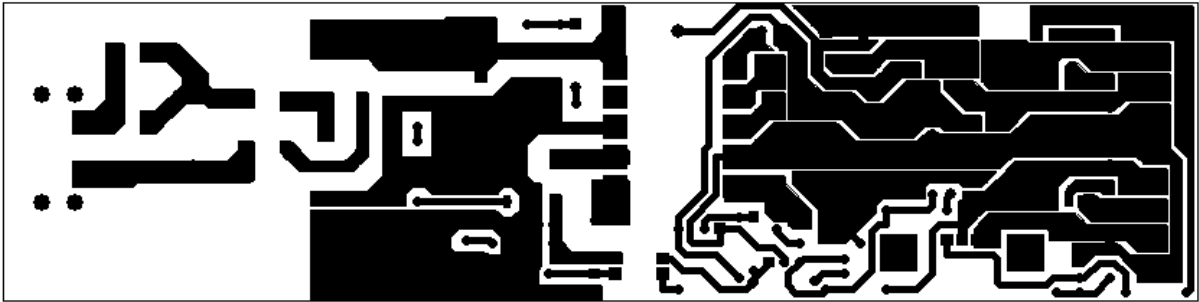

Figure 3 - PCB copper design. Scale not 1:1

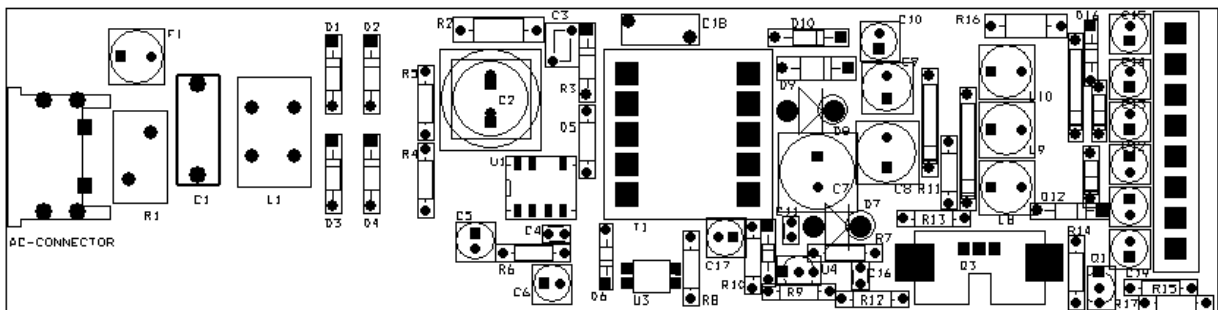

Figure 4 - Component Placement. Scale not 1:1

7 Transformer Specification

7.1 Electrical Diagram

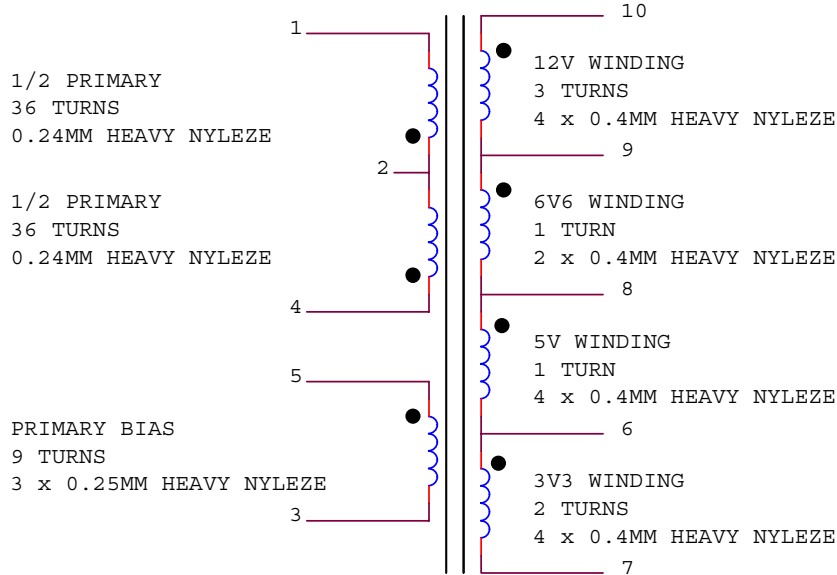

Figure 5 –Transformer Electrical Diagram

7.2 Electrical Specifications

Electrical Strength	1 second, 60 Hz, from Pins 1-5 to Pins 6-10	3000 VAC
Primary Inductance	Pins 1-4, all other windings open, measured at 100 kHz, 0.4 VRMS	1750 μ H, -0/+20%
Resonant Frequency	Pins 1-4, all other windings open	600 kHz (Min.)
Primary Leakage Inductance	Pins 1-4, with Pins 6-10 shorted, measured at 100 kHz, 0.4 VRMS	60 μ H (Max.)

7.3 Materials

Item	Description
[1]	Core: EF25 Gapped for ALG value of 344nH/T^2 (Approx 0.15mm gap in center leg)
[2]	Bobbin: 10 pin EF25 (Philips P/N CPH-E25/13/7-1S-10P)
[3]	Magnet Wire: 0.24mm Heavy Nyleze
[4]	Magnet Wire: 0.4mm Heavy Nyleze
[5]	Tape: 3M Type 1298 Polyester Film or Equivalent 15mm Wide
[6]	Varnish



7.4 Transformer Build Diagram

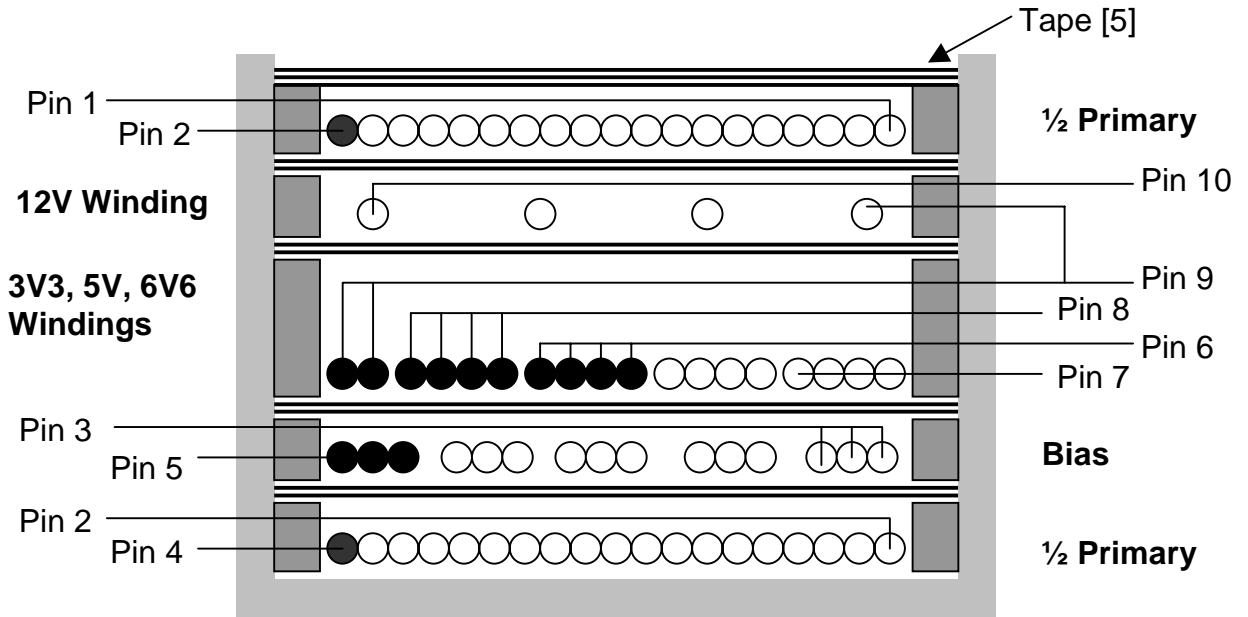

Figure 6 – Transformer Build Diagram.

7.5 Transformer Construction

Primary Margin	Apply 3mm wide margin tape to each side of the bobbin. Re-apply margin tape after each layer of tape.
Primary	Start at Pin 4. Wind 32 turns of item [3] in approximately 1 layer. Bring finish lead back to start. Finish on Pin 2.
Basic Insulation	Use two layers of item [6] for basic insulation.
Tri-filar Bias Winding	Starting at Pin 5, wind 5 trifilar turns of item [3]. Spread turns evenly across bobbin. Finish at Pin 3.
Safety Insulation	Use three layers of item [6] for safety insulation.
3V3, 5V and 6V6 Windings	Start at Pin 7. Wind 2 quadrifilar turns of item [4] and finish on pin 6. Start on Pin 6, wind a single quadrifilar turn of item [4] and finish on Pin 8. Start on Pin 8, wind a single bi-filar turn of item [4] and finish on pin 9. These three windings should occupy a single full layer.
12V Winding	Start at Pin 9. Wind 3 turns of item [4] and finish on Pin 10. This winding should be spread across the width of the transformer bobbin, between the margin tape.
Outer Wrap	Wrap windings with 3 layers of tape item [6].
Final Assembly	Assemble and secure core halves and varnish impregnate, item [6].

8 Transformer Spreadsheets

The spreadsheet below gives the output from PI Expert software which has been used to design the power supply. Key design parameters can be found in the spreadsheet including device operating current/voltage, transformer design and the RMS currents in power stage capacitors and diodes.

8.1 230V Mains Design

The spreadsheet below details the operating parameters for the power supply operating from 230V mains.

Power Supply Input

VACMIN	Volts	195					Min Input AC Voltage
VACMAX	Volts	265					Max Input AC Voltage
FL	Hertz	50					AC Main Frequency
TC	mSeconds	1.79					Bridge Rectifier Conduction Time Estimate
Z		0.64					Loss Allocation Factor
N	%	76.0					Efficiency Estimate

Power Supply Outputs

VOx	Volts		3.30	5.00	6.60	12.00	Output Voltage
IOx	Amps		1.402	0.985	0.668	0.055	Output Current
VB	Volts	15.00					Bias Voltage
IB	Amps	0.006					Bias Current

Device Variables

Device		TOP242P/G					Device Name
PO	Watts	14.71					Total Output Power
VDRAIN	Volts	678					Maximum Drain Voltage Estimate (Includes Effect of Leakage Inductance)
VDS	Volts	7.1					Device On-State Drain to Source Voltage
FS	Hertz	132000					Device Switching Frequency
KRPKDP		0.88					Ripple to Peak Current Ratio
KI		1.00					External Current Limit Ratio
ILIMITEXT	Amps	0.42					Device Current Limit External Minimum
ILIMITMIN	Amps	0.42					Device Current Limit Minimum
ILIMITMAX	Amps	0.48					Device Current Limit Maximum
IP	Amps	0.40					Peak Primary Current



IRMS	Amps	0.15					Primary RMS Current
DMAX		0.37					Maximum Duty Cycle

Power Supply Components Selection

CIN	uFarads	15.0					Input Filter Capacitor
VMIN	Volts	234					Minimum DC Input Voltage
VMAX	Volts	375					Maximum DC Input Voltage
VCLO	Volts	200					Clamp Zener Voltage
PZ	Watts	1.9					Estimated Primary Zener Clamp Loss
VDB	Volts	0.7					Bias Winding Diode Forward Voltage Drop
PIVB	Volts	59					Bias Rectifier Maximum Peak Inverse Voltage

Power Supply Output Parameters

VDx	Volts		0.5	0.5	0.5	0.7	Output Winding Diode Forward Voltage Drop
PIVSx	Volts		14	20	26	47	Output Rectifier Maximum Peak Inverse Voltage
ISPx	Amps		4.18	2.94	1.99	0.16	Peak Secondary Current
ISRMSx	Amps		2.04	1.43	0.97	0.08	Secondary RMS Current
IRIPPLEx	Amps		1.48	1.04	0.70	0.06	Output Capacitor RMS Ripple Current

Transformer Construction Parameters

Core/Bobbin		E25/13/7 (EF25) Margi					Core and Bobbin Type
Core Manuf.		Generic					Core Manufacturing
Bobbin Manuf		Generic					Bobbin Manufacturing
LP	uHenries	1735					Primary Inductance
NP		71					Primary Winding Number of Turns
NB		8.26					Bias Winding Number of Turns
OD Actual	mm	0.20					Primary Actual Wire Diameter
Primary Current Density	A/mm ²	5					Primary Winding Current Density
VOR	Volts	135.00					Reflected Output Voltage
BW	mm	15.30					Bobbin Physical Winding Width
M	mm	3.0					Safety Margin Width



L		2.0					Number of Primary Layers
AE	cm ²	0.53					Core Effective Cross Section Area
ALG	nH/T ²	344					Gapped Core Effective Inductance
BM	mTesla	184					Maximum Operating Flux Density
BP	mTesla	224					Peak Flux Density
BAC	mTesla	81					AC Flux Density for Core Curves
LG	mm	0.15					Gap Length
LL	uHenries	34.7					Estimated Transformer Primary Leakage Inductance
LSEC	nHenries	20					Estimated Secondary Trace Inductance

Secondary Parameters

NSx			2.00	2.89	3.74	6.68	Secondary Number of Turns
Rounded Down NSx				2	3	6	Rounded to Integer Secondary Number of Turns
Rounded Down Vox	Volts			3.30	5.20	10.70	Auxiliary Output Voltage for Rounded to Integer NSx
Rounded Up NSx				3	4	7	Rounded to Next Integer Secondary Number of Turns
Rounded Up Vox	Volts			5.20	7.10	12.60	Auxiliary Output Voltage for Rounded to Next Integer NSx
ODS Actual Range	mm		0.45 - 0.72	0.40 - 0.64	0.32 - 0.51	0.09 - 0.14	Secondary Actual Wire Diameter Range

8.2 Universal Mains Design

The spreadsheet below details the operating parameters for the power supply operating with universal mains input. Here, the transformer is the same as for the 230V design but the input capacitor has been changed from 15uF to 47uF and the TOP242P to TOP243P.

Power Supply Input

VACMIN	Volts	85					Min Input AC Voltage
VACMAX	Volts	265					Max Input AC Voltage
FL	Hertz	50					AC Main Frequency
TC	mSeconds	2.38					Bridge Rectifier Conduction Time Estimate
Z		0.52					Loss Allocation Factor
N	%	72.0					Efficiency Estimate



Power Supply Outputs

VOx	Volts		3.30	5.00	6.60	12.00	Output Voltage
IOx	Amps		1.402	0.985	0.668	0.055	Output Current
VB	Volts	15.00					Bias Voltage
IB	Amps	0.006					Bias Current

Device Variables

Device		TOP243P/G					Device Name
PO	Watts	14.71					Total Output Power
VDRAIN	Volts	678					Maximum Drain Voltage Estimate (Includes Effect of Leakage Inductance)
VDS	Volts	4.9					Device On-State Drain to Source Voltage
FS	Hertz	132000					Device Switching Frequency
KRPKDP		0.43					Ripple to Peak Current Ratio
KI		1.00					External Current Limit Ratio
ILIMITEXT	Amps	0.70					Device Current Limit External Minimum
ILIMITMIN	Amps	0.70					Device Current Limit Minimum
ILIMITMAX	Amps	0.80					Device Current Limit Maximum
IP	Amps	0.48					Peak Primary Current
IRMS	Amps	0.30					Primary RMS Current
DMAX		0.62					Maximum Duty Cycle

Power Supply Components Selection

CIN	uFarads	47.0					Input Filter Capacitor
VMIN	Volts	88					Minimum DC Input Voltage
VMAX	Volts	375					Maximum DC Input Voltage
VCLO	Volts	200					Clamp Zener Voltage
PZ	Watts	2.8					Estimated Primary Zener Clamp Loss
VDB	Volts	0.7					Bias Winding Diode Forward Voltage Drop
PIVB	Volts	59					Bias Rectifier Maximum Peak Inverse Voltage

Power Supply Output Parameters

VDx	Volts		0.5	0.5	0.5	0.7	Output Winding Diode Forward Voltage Drop
PIVSx	Volts		14	20	26	47	Output Rectifier Maximum Peak Inverse Voltage



ISP _x	Amps		5.07	3.56	2.41	0.20	Peak Secondary Current
IS _{RMSx}	Amps		2.49	1.75	1.19	0.10	Secondary RMS Current
IRIPPLE _x	Amps		2.06	1.44	0.98	0.08	Output Capacitor RMS Ripple Current

Transformer Construction Parameters

Core/Bobbin		E25/13/7 (EF25) Margi					Core and Bobbin Type
Core Manuf.		Generic					Core Manufacturing
Bobbin Manuf		Generic					Bobbin Manufacturing
LP	uHenries	1750					Primary Inductance
NP		72					Primary Winding Number of Turns
NB		8.32					Bias Winding Number of Turns
OD Actual	mm	0.20					Primary Actual Wire Diameter
Primary Current Density	A/mm ²	9					Primary Winding Current Density
VOR	Volts	135.00					Reflected Output Voltage
BW	mm	15.30					Bobbin Physical Winding Width
M	mm	3.0					Safety Margin Width
L		2.0					Number of Primary Layers
AE	cm ²	0.53					Core Effective Cross Section Area
ALG	nH/T ²	342					Gapped Core Effective Inductance
BM	mTesla	222					Maximum Operating Flux Density
BP	mTesla	373					Peak Flux Density
BAC	mTesla	48					AC Flux Density for Core Curves
LG	mm	0.16					Gap Length
LL	uHenries	35.0					Estimated Transformer Primary Leakage Inductance
LSEC	nHenries	20					Estimated Secondary Trace Inductance

Secondary Parameters

NS _x			2.01	2.92	3.76	6.73	Secondary Number of Turns
Rounded Down NS _x				2	3	6	Rounded to Integer Secondary Number of Turns
Rounded Down Vox	Volts			3.27	5.16	10.62	Auxiliary Output Voltage for Rounded to Integer NS _x



Rounded Up NSx				3	4	7	Rounded to Next Integer Secondary Number of Turns
Rounded Up Vox	Volts			5.16	7.05	12.51	Auxiliary Output Voltage for Rounded to Next Integer NSx
ODS Actual Range	mm		0.57 - 0.91	0.45 - 0.72	0.36 - 0.57	0.11 - 0.16	Secondary Actual Wire Diameter Range



9 Prototype Performance

All measurements were performed with the prototype sitting horizontally in free air conditions with a lab ambient of 27°C unless otherwise stated.

9.1 230V Prototype Performance Measurements

The PCB was fitted with the components for 230V operation.

9.1.1 Efficiency

Efficiency was measured as a function of mains input voltage under the maximum loading conditions defined in Table 1. Figure 7 shows the overall conversion efficiency measured before and after the regulators for the 1V2 and 2V5 rails. The efficiency before the linear regulators is presented to give an indication of the PSU performance without the loss introduced by the linear regulator circuitry.

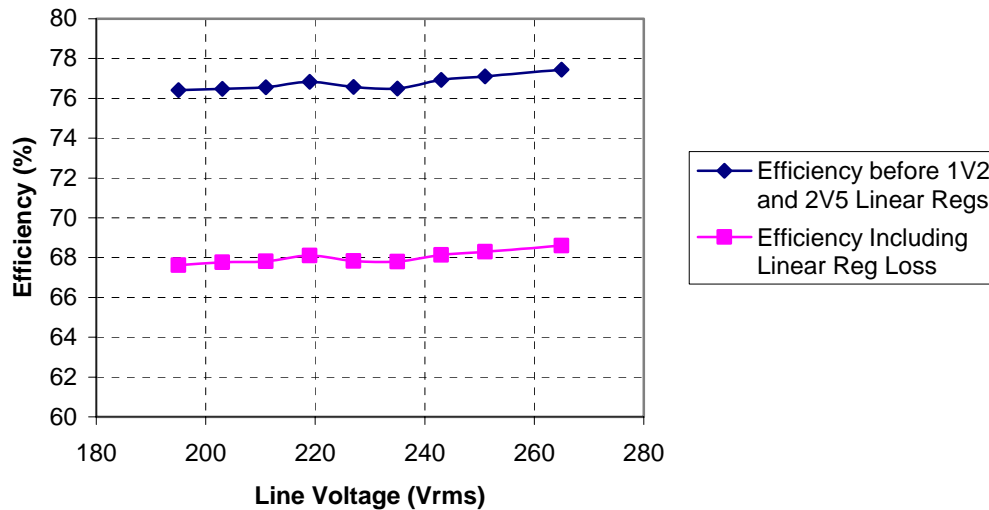

Figure 7 - Efficiency Variation with Line Voltage

The efficiency curve shows good performance of the general switched mode section of the power supply. The loss in the linear regulators does compromise the efficiency slightly, although the additional heating introduced is shown to be manageable in Figure 10.



9.1.2 Line Regulation

Regulation of the output was measured as a function of mains voltage under maximum loading conditions. Figure 8 gives the results, expressed as a function of nominal rail voltage (i.e. 0% is ideal output voltage).

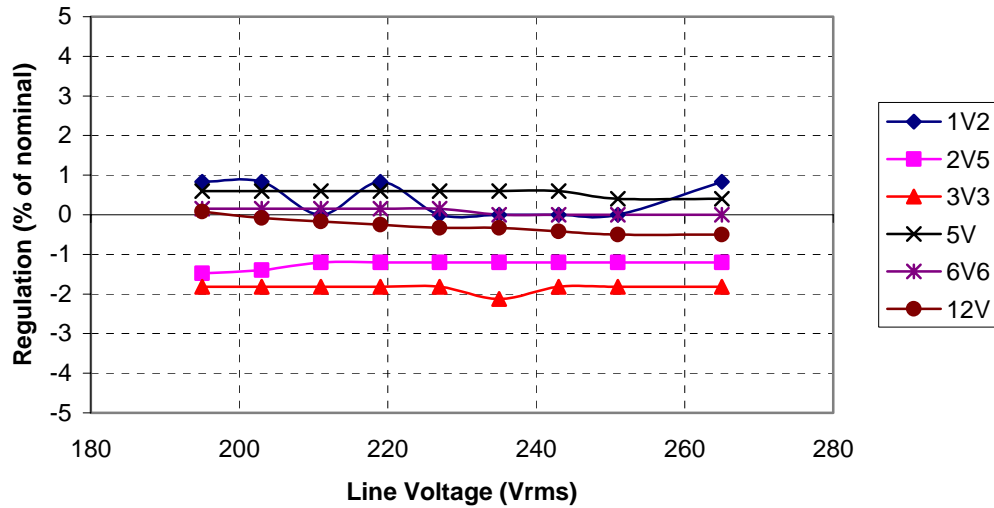

Figure 8 - Voltage Regulation Variation with Line Voltage

Under full load conditions, all rails are well within +/-5% of nominal values.



9.1.3 Cross Regulation

Minimum loads were given for all rails although, at present, loading combinations are unknown. For cross-regulation measurements, worst case loading conditions have been measured as shown in Figure 9.

Rail Voltage (V)	1.2	2.5	3.3	5	6.6	12
Min Load (A) X	0.035	0.03	0.152	0.121	0.1	0.03
Max Load (A) M	0.759	0.215	0.428	0.985	0.668	0.055
XXXXXX	1.22	2.54	3.24	5.07	6.51	11.56
XXXXXM	1.21	2.55	3.25	5.06	6.5	11.1
XXXXMX	1.23	2.54	3.25	5.05	6.28	11.62
XXXMXX	1.24	2.59	3.29	4.87	6.65	12.02
XXMXXX	1.24	2.51	3.22	5.14	6.62	11.82
XMXXXX	1.24	2.43	3.23	5.12	6.59	11.79
MXXXXX	1.24	2.48	3.19	5.23	6.76	12.08
MMMMMX	1.236	2.45	3.24	5.03	6.6	12.29
MMMMXM	1.21	2.47	3.24	5.04	6.94	12.11
MMXMM	1.21	2.41	3.19	5.22	6.53	11.71
MMXMM	1.22	2.47	3.25	5	6.49	11.89
MXMMMM	1.22	2.56	3.24	5.02	6.59	11.93
XMMMMM	1.22	2.49	3.26	4.96	6.5	11.71
MMMMMM	1.21	2.47	3.24	5.03	6.61	11.99
Min (V)	1.21	2.41	3.19	4.87	6.28	11.1
Max (V)	1.24	2.59	3.29	5.23	6.94	12.29

Figure 9 - Cross Regulation at 230V input

Worst case loading occurs when one rail is at one loading extreme and all the others are at the other extreme. In the case when all rails are running at maximum power and one rail is run at minimum power, the minimum power rail suffers peak charging and its voltage will increase. In the case when all rails are at minimum load except one at maximum, the maximum load rail will sag since the lightly loading rails will peak charge causing a small error in the feedback.

The worst case measurements given above indicate that despite these effects, the PSU outputs still remain in regulation specifications.



9.1.4 Thermal Measurements

During the full power efficiency measurements of section Figure 7, the temperature of a number of key power conversion components were measured using thermocouples attached with 'wiretak' adhesive. Figure 10 gives the temperature of the selected components as a function of input line voltage. Each data point was allowed 5 minutes to thermally stabilize before being recorded. The power supply was run for 15 minutes before the first data point was measured.

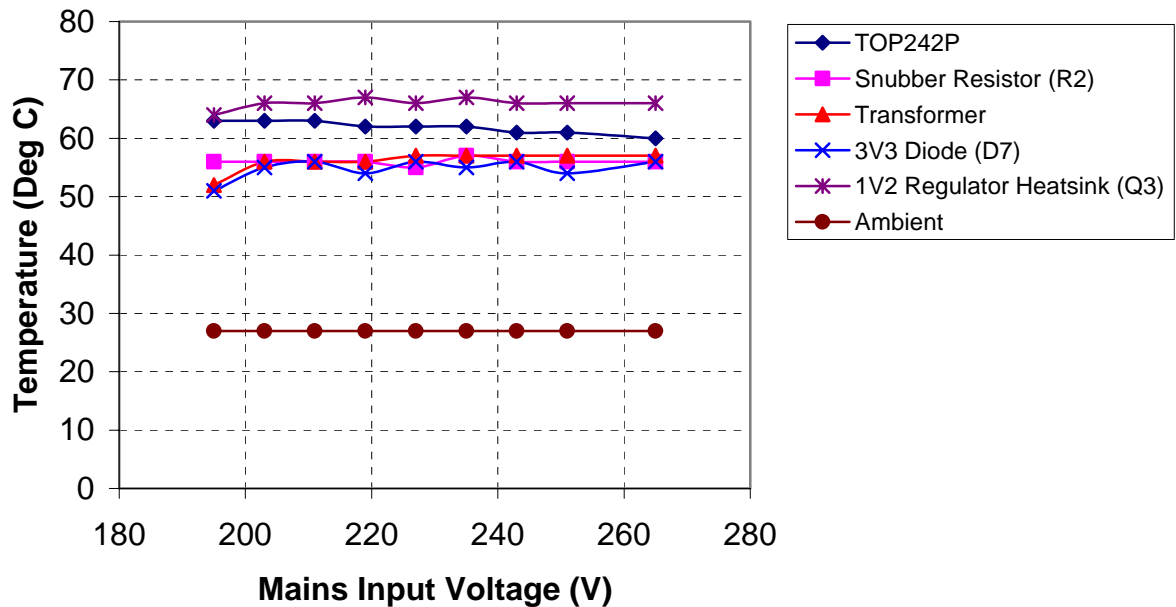

Figure 10 - Device Temperature Variation with Line Voltage



9.1.5 230V Prototype Waveform Measurements

9.1.5.1 Drain-Source Voltage and Drain Current at full Power

TOPSwitch Drain-Source voltage and Drain current under full power operation are shown in Figure 11 under low line and high line conditions.

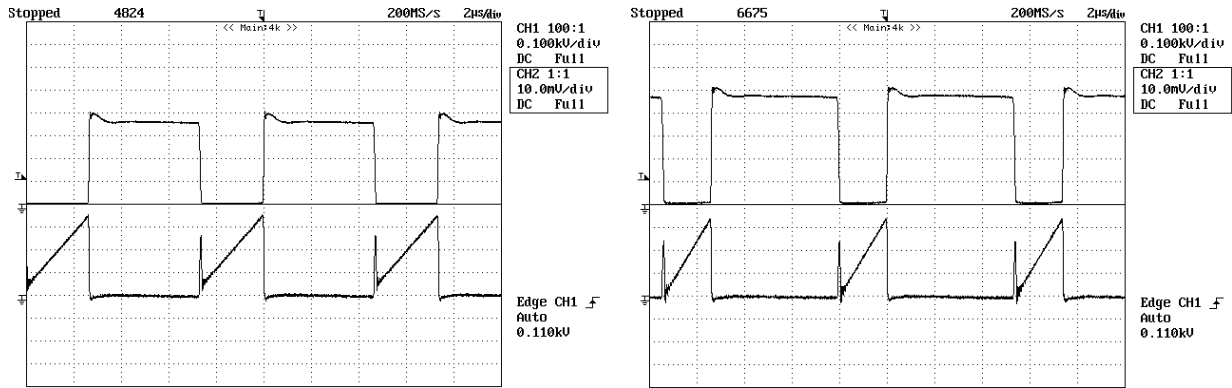

Figure 11 - Drain-Source Voltage (Upper at 100V/div) and Drain Current (Lower at 0.1A/div). Left Hand Side is 195V_{ac} input and Right Hand Side is 265V_{ac}. Timebase is 2us/div

Both device voltage and current are within specifications.

9.1.6 Primary Side Start-up Waveforms

The waveforms given in Figure 12 show the soft-start action of the TOP242P. The plot also shows a zoom to give the actual switching waveforms at the highest point of device current during start-up.

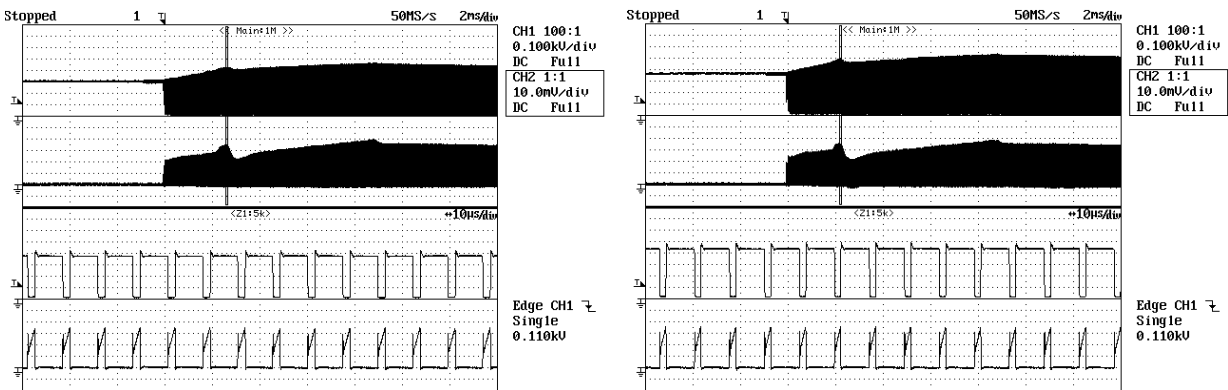

Figure 12 - Primary Side Start-up Behaviour. (Upper is Drain-Source Voltage (100V/div) and Lower is Drain Current (0.1A/div)). Left Hand Side is 195V_{ac} input and Right Hand Side is 265V_{ac}. Timebase is 2ms/div



9.1.6.1 Output Voltage Start-up Behavior

The start-up behavior of each rail was measured using resistive loads on the outputs. Figure 13 shows the start-up behavior of the 1V2, 2V5, 3V3 and 5V rails whilst Figure 14 gives the 6V6 and 12V start-up with 1V2 as a reference.

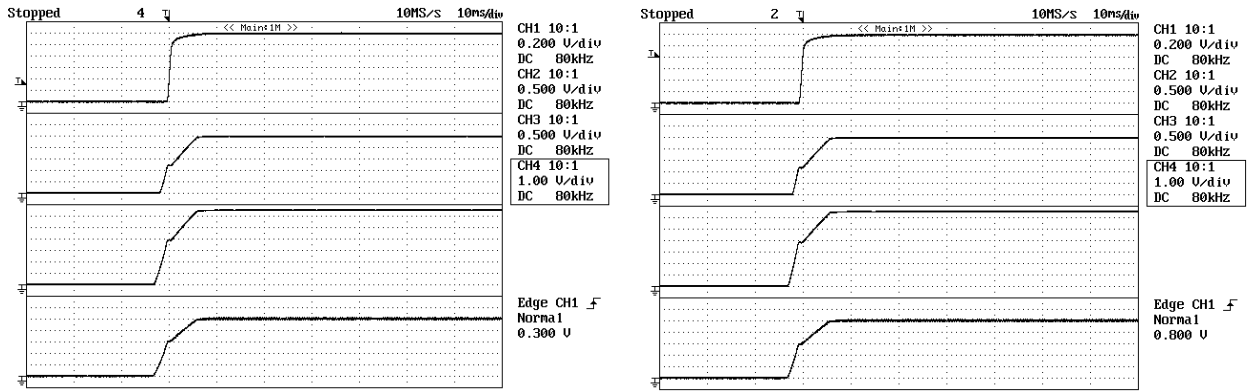

Figure 13 - Start-up Behavior of 1V2 (Top 0.2V/div), 2V5 (Second From Top 0.5V/div), 3V3 (Third from Top 0.5V/div), 5V (Bottom 1V/div). Left Hand Side is 195V_{ac} input and Right Hand Side is 265V_{ac}. Timebase is 10ms/div.

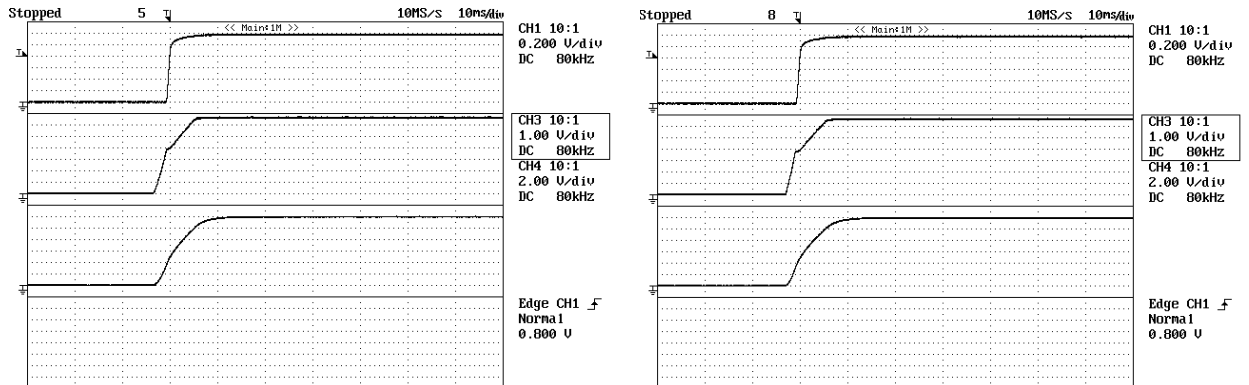

Figure 14 - Start-up Behavior of 1V2 (Top 0.2V/div), 6V6 (Second From Top 1V/div), 12V (Bottom 2V/div). Left Hand Side is 195V_{ac} input and Right Hand Side is 265V_{ac}. Timebase is 10ms/div.

All rails start-up within 10ms and have zero voltage overshoot.



9.1.6.2 Output Ripple and Noise

9.1.6.3 Ripple Measurement Technique

For DC output ripple measurements, a modified oscilloscope test probe must be utilized in order to reduce spurious signals due to pickup. Details of the probe modification are provided in Figure 15 and Figure 16.

The 5125BA probe adapter is affixed with two capacitors tied in parallel across the probe tip. The capacitors include one (1) 0.1 $\mu\text{F}/50\text{ V}$ ceramic type and one (1) 1.0 $\mu\text{F}/50\text{ V}$ aluminum electrolytic. ***The aluminum electrolytic type capacitor is polarized, so proper polarity across DC outputs must be maintained (see below).***

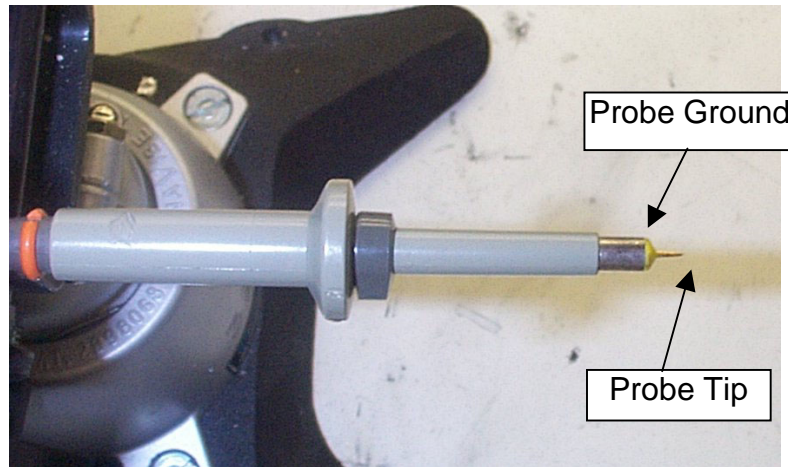

Figure 15 - Oscilloscope Probe Prepared for Ripple Measurement. (End Cap and Ground Lead Removed)

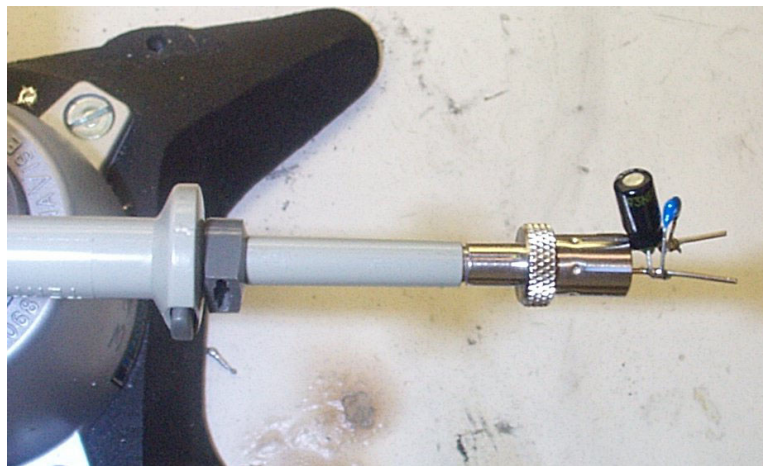

Figure 16 - Oscilloscope Probe with Probe Master 5125BA BNC Adapter. (Modified with wires for probe ground for ripple measurement, and two parallel decoupling capacitors added)

9.1.6.4 Measured Noise and Ripple

All waveforms were measured with 230V mains input and at full operating power. All results AC coupled.

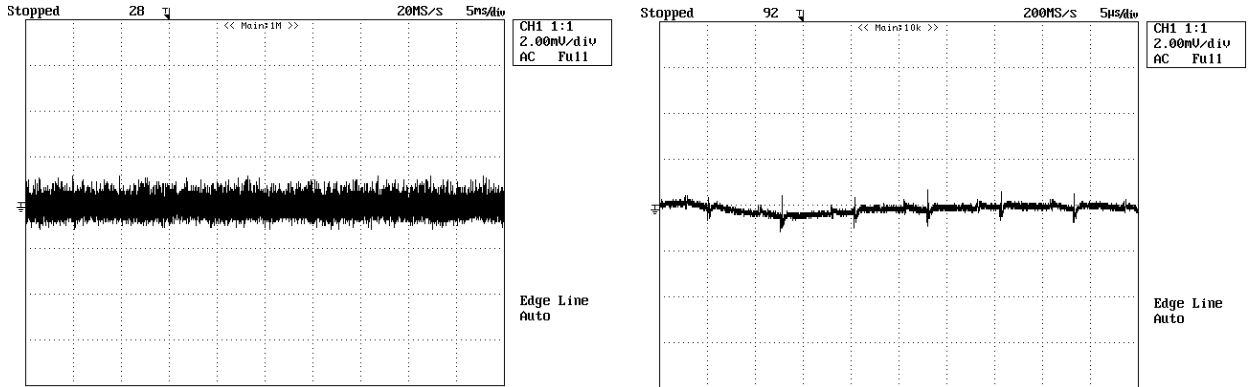

Figure 17 – 1V2 Rail. Output 100Hz ripple (LHS, 5ms/div and 2mV/div) and 132kHz noise (RHS, 5µs/div and 2mV/div)

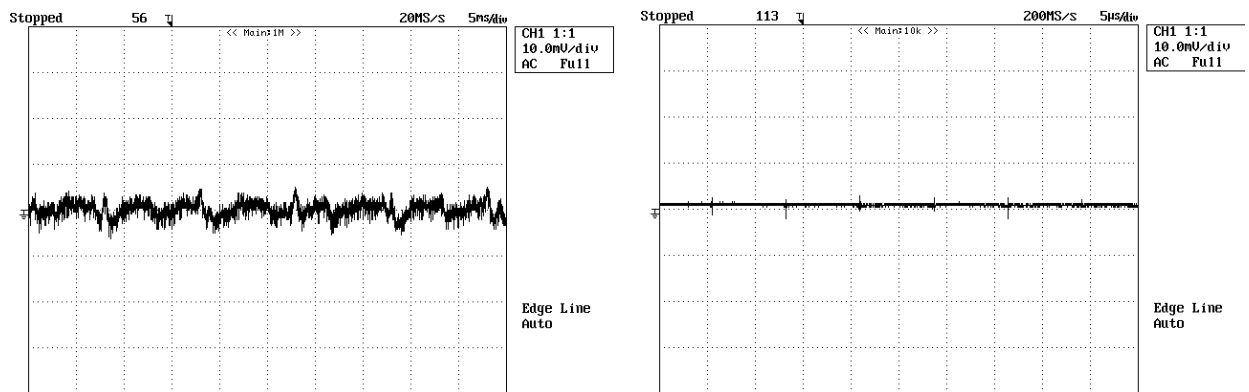

Figure 18 – 2V5 Rail. Output 100Hz ripple (LHS, 5ms/div and 10mV/div) and 132kHz noise (RHS, 5µs/div and 10mV/div)

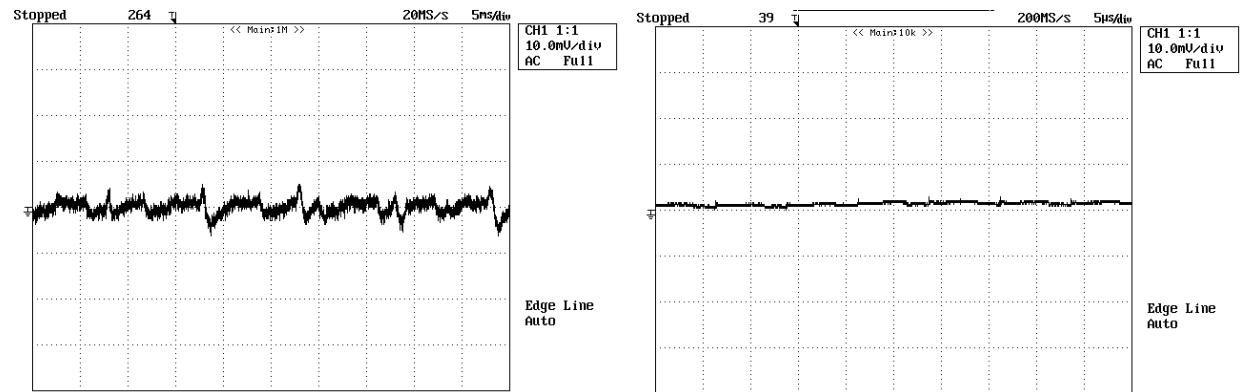

Figure 19 – 3V3 Rail. Output 100Hz ripple (LHS, 5ms/div and 10mV/div) and 132kHz noise (RHS, 5µs/div and 10mV/div)



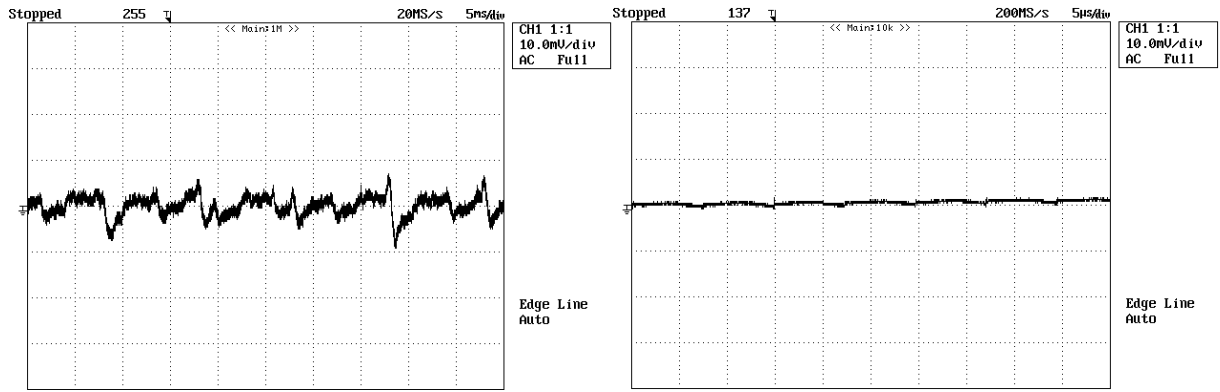

Figure 20 – 5V Rail. Output 100Hz ripple (LHS, 5ms/div and 10mV/div) and 132kHz noise (RHS, 5us/div and 10mV/div)

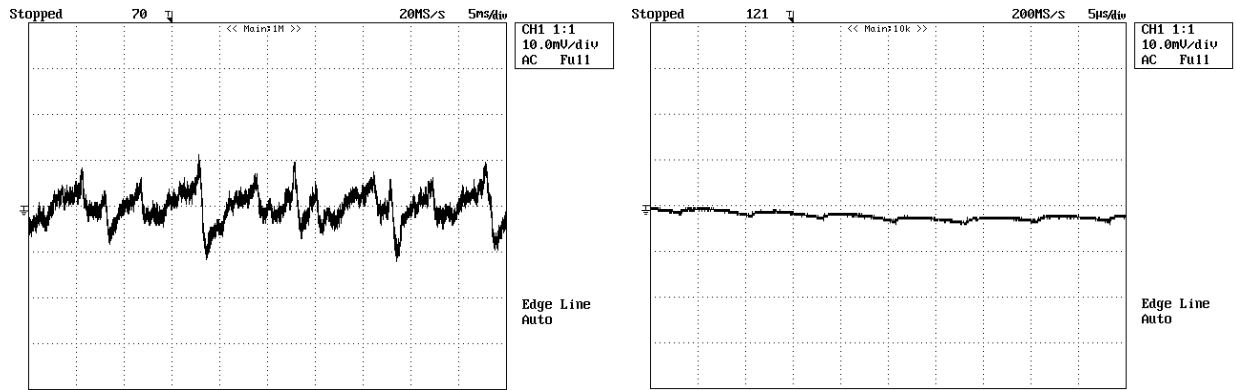

Figure 21 – 6V6 Rail. Output 100Hz ripple (LHS, 5ms/div and 10mV/div) and 132kHz noise (RHS, 5us/div and 10mV/div)

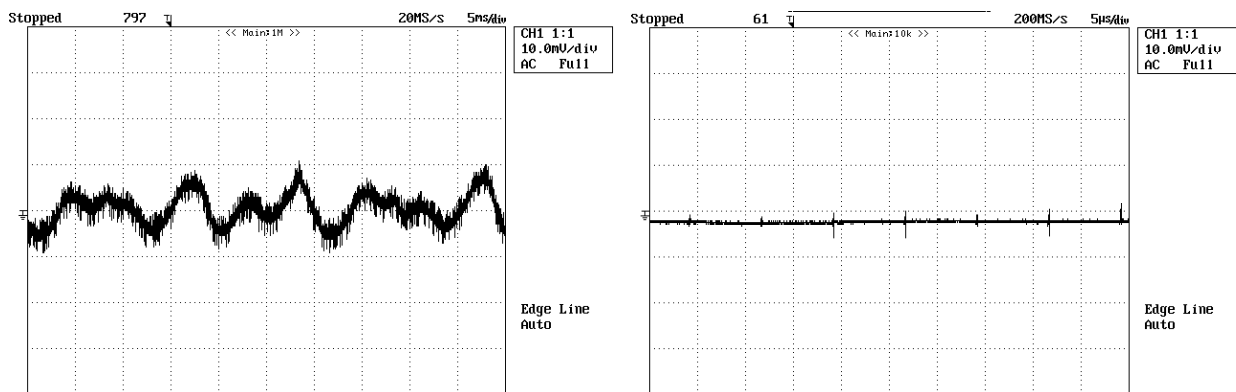

Figure 22 – 12V Rail. Output 100Hz ripple (LHS, 5ms/div and 10mV/div) and 132kHz noise (RHS, 5us/div and 10mV/div)



9.1.6.5 Transient Loading

In order to give an indication of loop stability, the load on the 3V3 rail was switched from 50% to 100% and the response of the rail measured. Figure 23 shows the results at 195V_{ac} and 265V_{ac}.

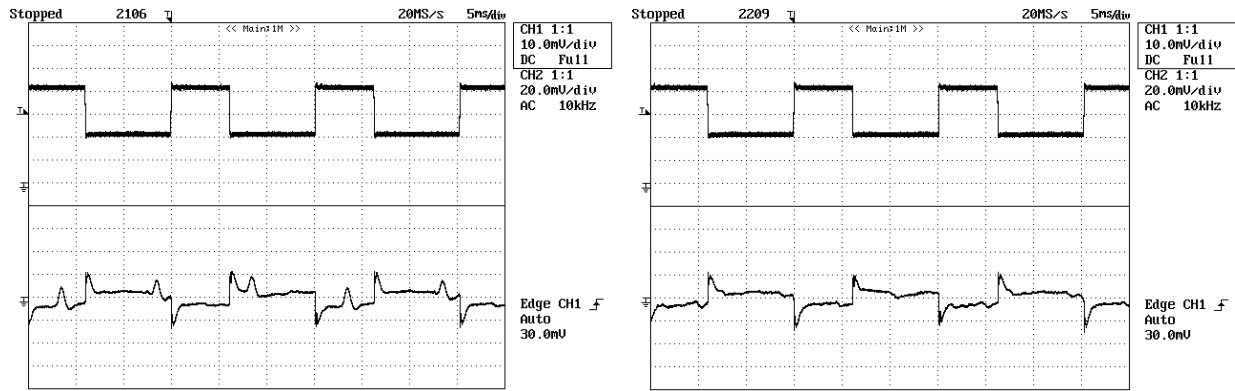

Figure 23 – Transient response on 3V3 rail. Upper is rail current at 0.1A/div and lower is AC coupled rail voltage at 20mV/div. Left Hand Side is 195V_{ac} input and Right Hand Side is 265V_{ac}.

The voltage response shows a well damped behavior which indicates a good phase/gain margin. For production verification, a network analyzer should be used to measure the control loop response at extremes of load, line voltage and operating temperature. In the measurement of Figure 23 with 195V_{AC} input, there is a small component of ripple due to 100Hz breakthrough which shows up in the transient response plot. The level is very low and completely independent of the transient recovery behavior.

9.1.7 Conducted EMI Measurements

The measurements presented in this section are pre-compliance and should only be used for guidance. Measurements are performed with 230V input and full power output. Figure 24 gives the conducted EMI measurement with the output floating and Figure 25 with the output grounded to protective earth to simulate grounding through a SCART lead.

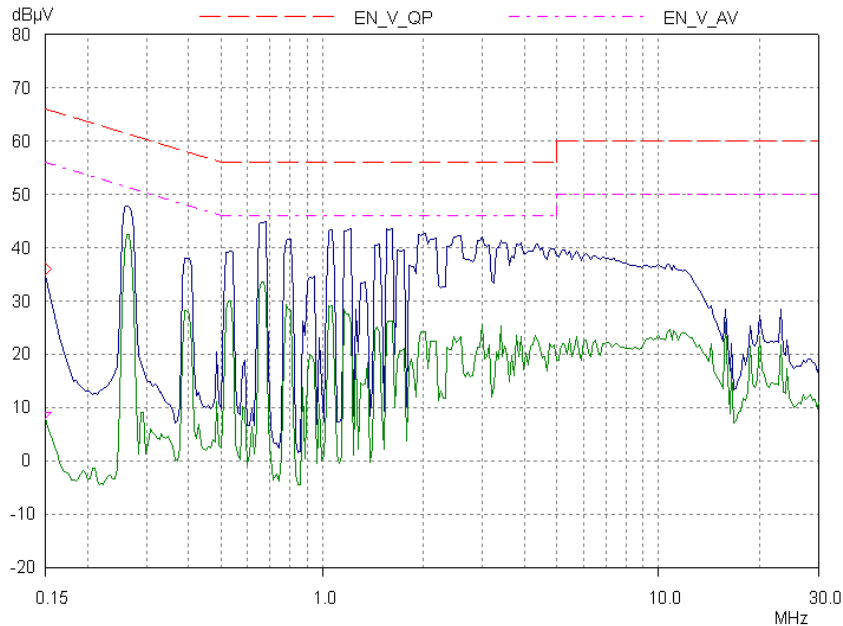

Figure 24 - EMI with Output Floating

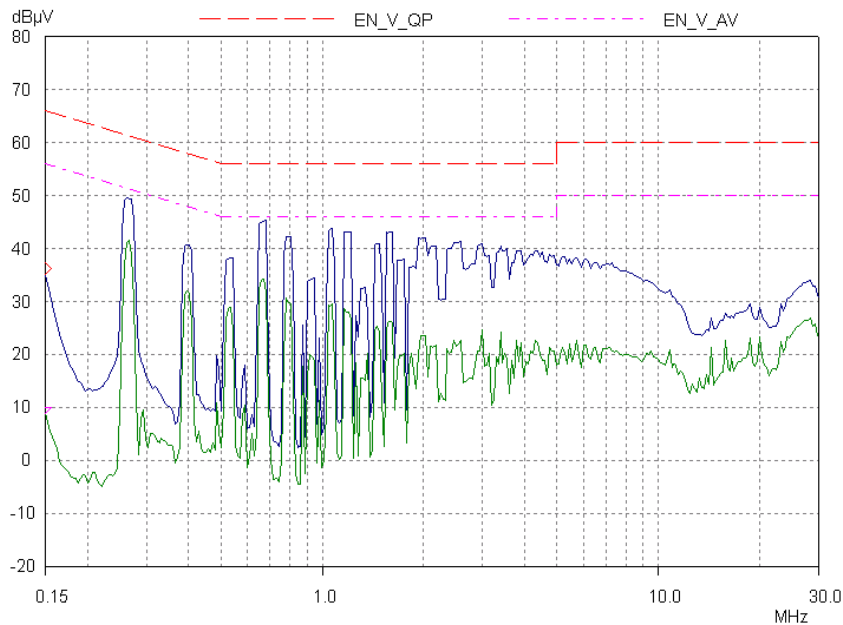

Figure 25 - EMI with Output Grounded to Protective Earth



9.2 Universal Mains Prototype Performance Measurements

The PCB was fitted with the components for Universal operation.

9.2.1 Efficiency

Efficiency was measured as a function of mains input voltage under the maximum loading conditions defined in Table 1. Figure 26 shows the overall conversion efficiency measured before and after the regulators for the 1V2 and 2V5 rails. The efficiency before the linear regulators is presented to give an indication of the PSU performance without the loss introduced by the linear regulator circuitry.

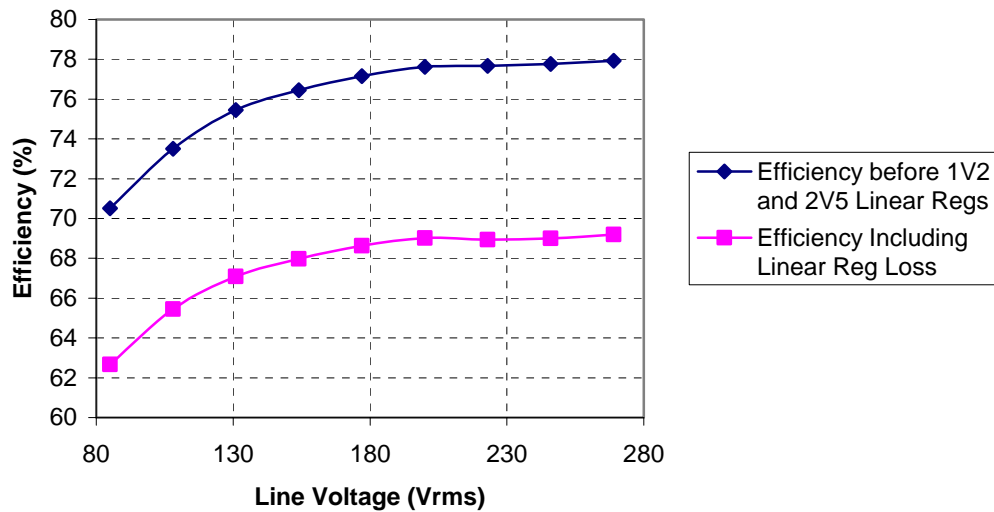

Figure 26 - Efficiency Variation with Line Voltage



9.2.2 Line Regulation

Regulation of the output was measured as a function of mains voltage under maximum loading conditions. Figure 27 gives the results, expressed as a function of nominal rail voltage (i.e. 0% is ideal output voltage).

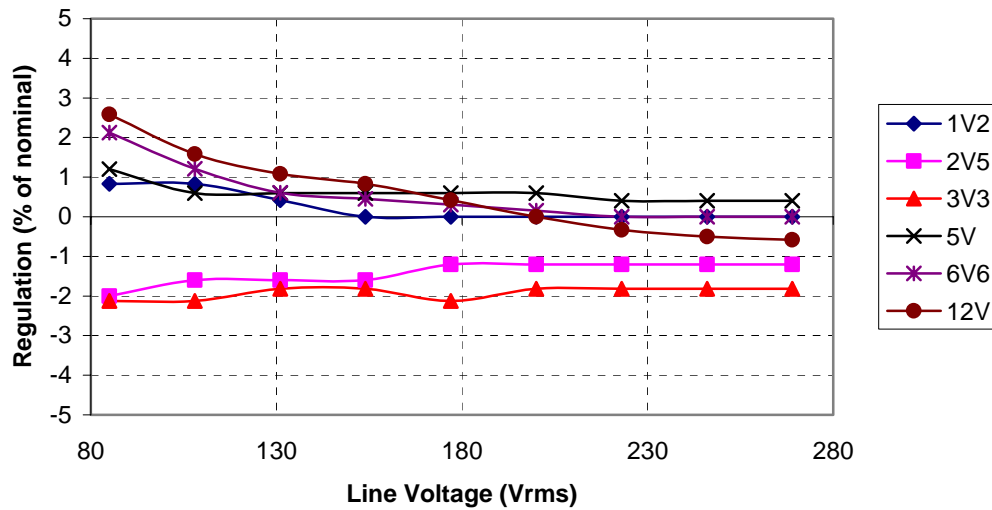

Figure 27 - Voltage Regulation Variation with Line Voltage

Under full load conditions, all rails are well within +/-5% of nominal values.



9.2.3 Cross Regulation

Cross-regulation was measured in the same manner as in section 9.1.3 using 115V as the mains input. Again, worst case loading has been assumed.

Rail Voltage (V)	1.2	2.5	3.3	5	6.6	12
Min Load (A) X	0.035	0.03	0.152	0.121	0.1	0.03
Max Load (A) M	0.759	0.215	0.428	0.985	0.668	0.055
XXXXXX	1.21	2.55	3.24	5.07	6.5	11.52
XXXXXM	1.22	2.54	3.25	5.06	6.48	11.1
XXXMX	1.2	2.56	3.24	5.04	6.27	11.58
XXMXX	1.22	2.6	3.29	4.87	6.66	12.03
XXMXX	1.22	2.52	3.22	5.14	6.61	11.78
XMXXX	1.23	2.44	3.23	5.12	6.58	11.71
MXXXX	1.23	2.49	3.19	5.23	6.75	12.07
MMMMX	1.2	2.46	3.23	5.05	6.68	12.46
MMMMXM	1.21	2.46	3.24	5.05	6.99	12.17
MMXMM	1.2	2.41	3.18	5.23	6.55	11.79
MMXMM	1.21	2.47	3.25	5.01	6.61	12.09
MXMMM	1.2	2.56	3.24	5.03	6.63	12.12
XMMMM	1.21	2.49	3.26	4.95	6.52	11.84
MMMMM	1.21	2.46	3.24	5.04	6.66	12.16
Min	1.2	2.41	3.18	4.87	6.27	11.1
Max	1.23	2.6	3.29	5.23	6.99	12.46

Figure 28 - Cross Regulation at 115V input

Cross-Regulation measurements at 230V are assumed to be the same as those measured on the 230V only prototype.



9.2.4 Thermal Measurements

During the full power efficiency measurements of section 9.2.1, the temperature of a number of key power conversion components were measured using thermocouples attached with 'wiretak' adhesive. Figure 29 gives the temperature of the selected components as a function of input line voltage. Each data point was allowed 5 minutes to thermally stabilize before being recorded. The power supply was run for 15 minutes before the first data point was measured.

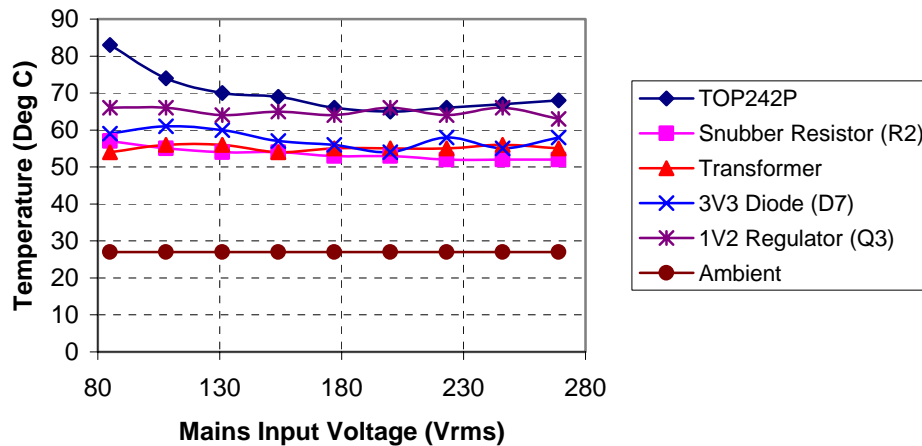

Figure 29 - Device Temperature Variation with Line Voltage



9.2.5 Universal Mains Prototype Waveform Measurements

9.2.5.1 Drain-Source Voltage and Drain Current at full Power

TOPSwitch Drain-Source voltage and Drain current under full power operation are shown in Figure 30 under low line and high line conditions.

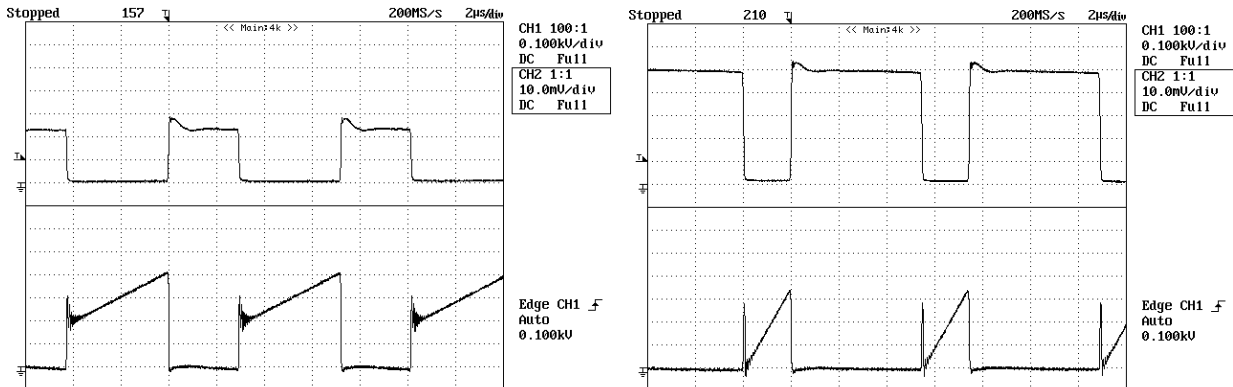

Figure 30 - Drain-Source Voltage (Upper at 100V/div) and Drain Current (Lower at 0.1A/div). Left Hand Side is 85V_{ac} input and Right Hand Side is 265V_{ac}. Timebase is 2µs/div

Both device voltage and current are within specifications.

9.2.6 Primary Side Start-up Waveforms

The waveforms given in Figure 31 show the soft-start action of the TOP243P. The plot also shows a zoom to give the actual switching waveforms at the highest point of device current during start-up.

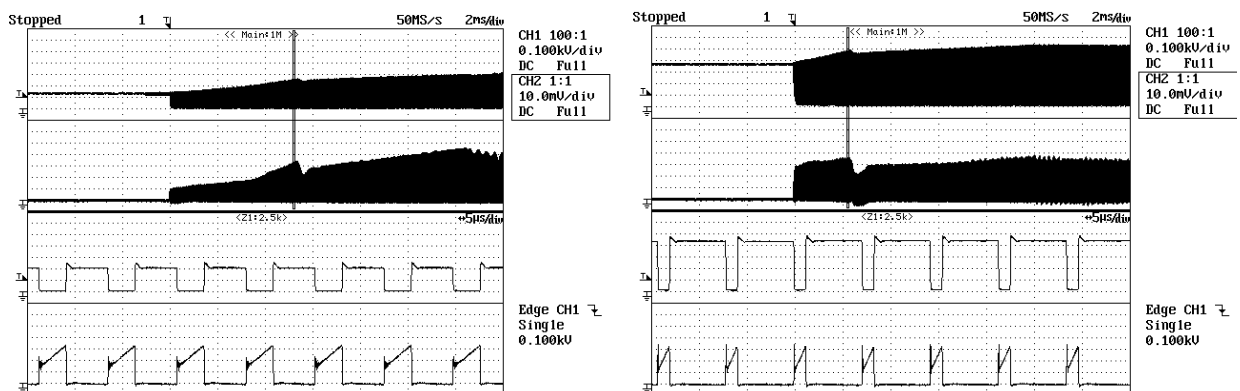

Figure 31 - Primary Side Start-up Behavior. (Upper is Drain-Source Voltage (100V/div) and Lower is Drain Current (0.1A/div)). Left Hand Side is 85V_{ac} input and Right Hand Side is 265V_{ac}. Timebase is 2ms/div



9.2.6.1 Output Voltage Start-up Behavior

The start-up behavior of each rail was measured using resistive loads on the outputs. Figure 32 shows the start-up behavior of the 1V2, 2V5, 3V3 and 5V rails whilst Figure 33 shows the 6V6 and 12V rails with the 1V2 start-up as a reference.

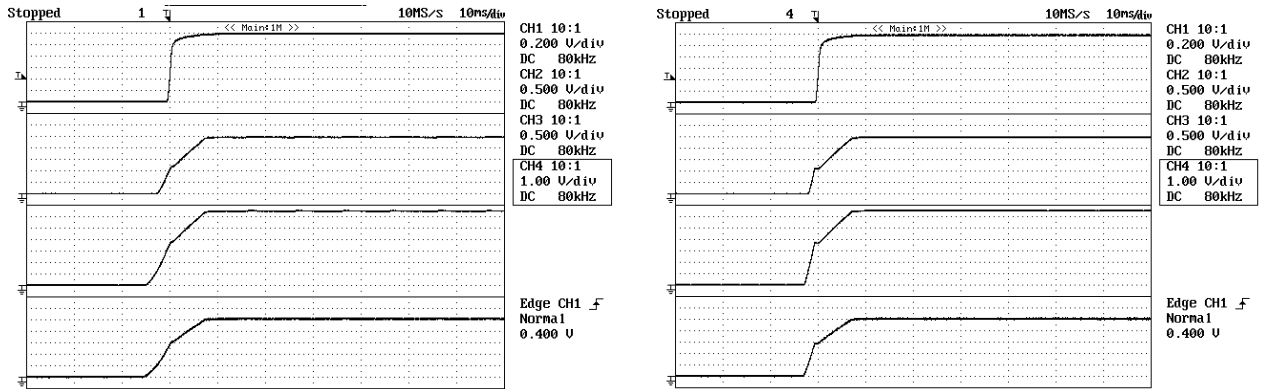

Figure 32 - Start-up Behavior of 1V2 (Top 0.2V/div), 2V5 (Second From Top 0.5V/div), 3V3 (Third from Top 0.5V/div), 5V (Bottom 1V/div). Left Hand Side is 85V_{ac} input and Right Hand Side is 265V_{ac}. Timebase is 10ms/div

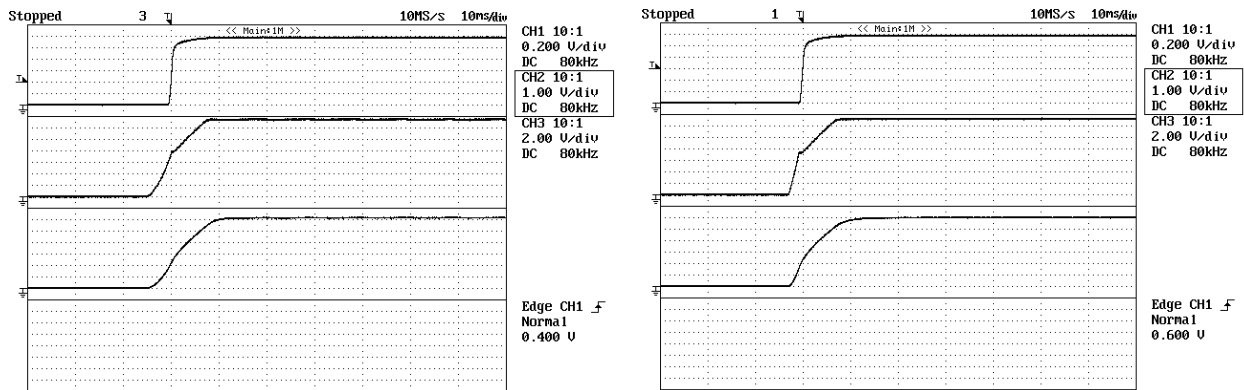

Figure 33 - Start-up Behavior of 1V2 (Top 0.2V/div), 6V6 (Second From Top 1V/div), 12V (Bottom 2V/div). Left Hand Side is 85V_{ac} input and Right Hand Side is 265V_{ac}. Timebase is 10ms/div

All rails start-up within 10ms and have zero voltage overshoot.



9.2.6.2 Measured Noise and Ripple

All waveforms were measured with 115V mains input and at full operating power. All results AC coupled.

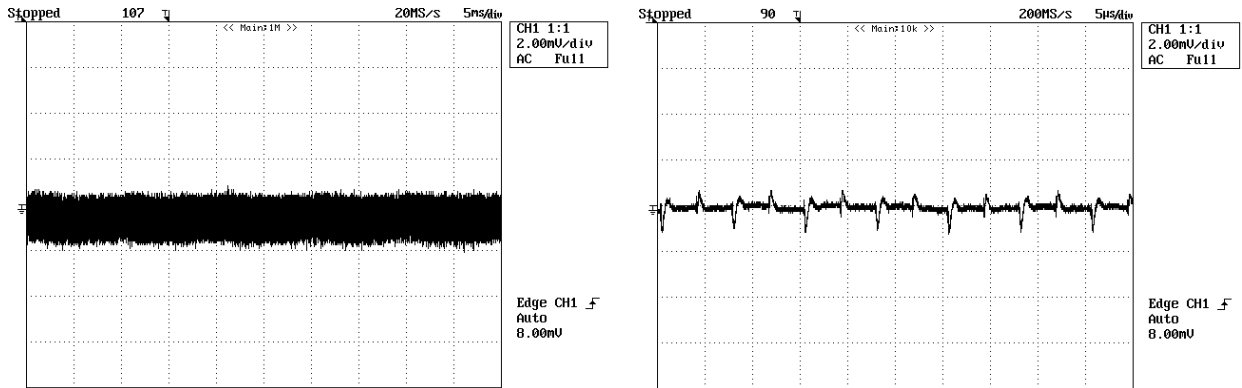

Figure 34 – 1V2 Rail. Output 100Hz ripple (LHS, 5ms/div and 2mV/div) and 132kHz noise (RHS, 5us/div and 2mV/div)

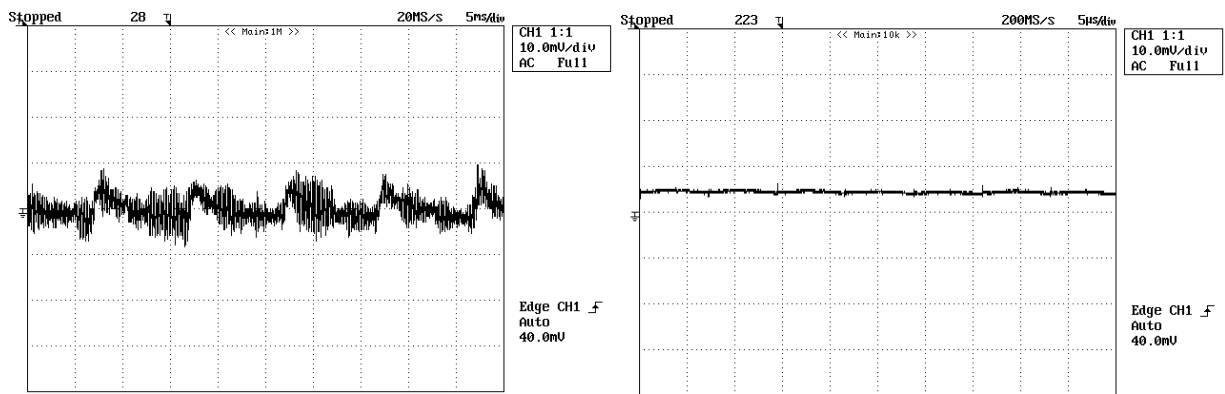

Figure 35 – 2V5 Rail. Output 100Hz ripple (LHS, 5ms/div and 10mV/div) and 132kHz noise (RHS, 5us/div and 10mV/div)

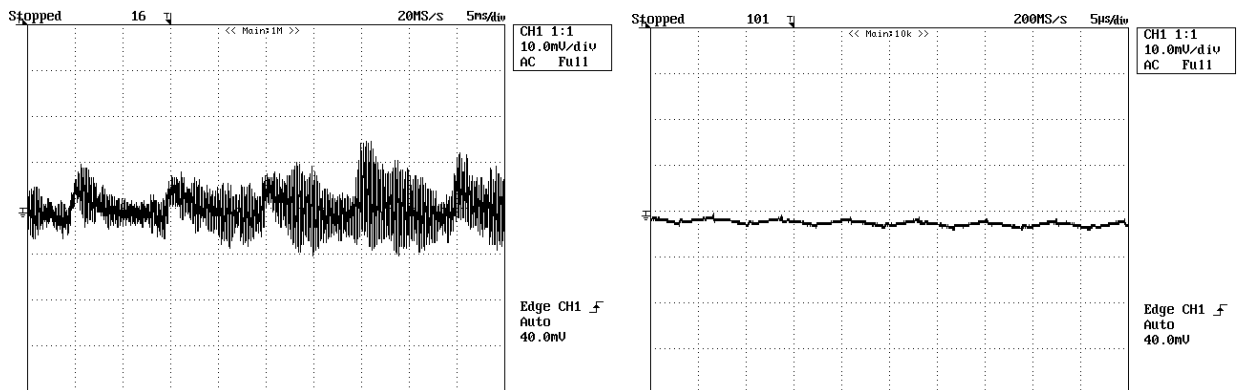

Figure 36 – 3V3 Rail. Output 100Hz ripple (LHS, 5ms/div and 10mV/div) and 132kHz noise (RHS, 5us/div and 10mV/div)



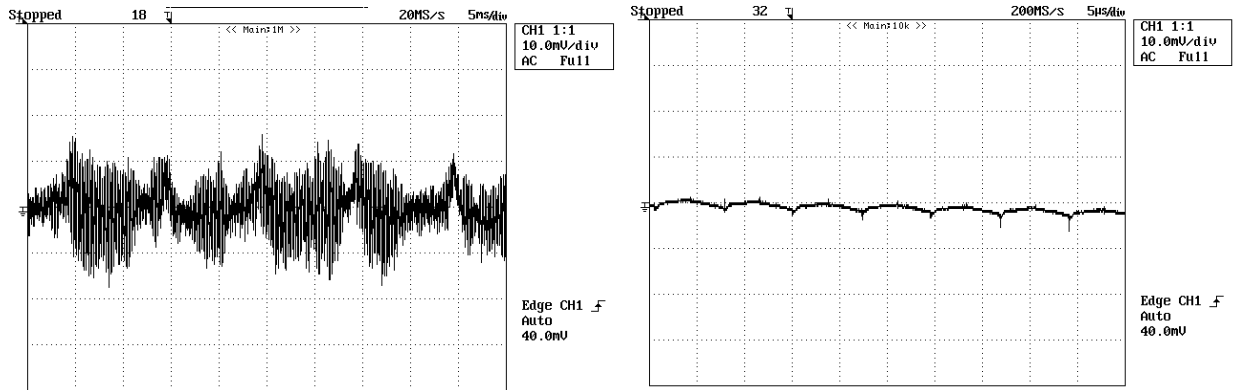

Figure 37 – 5V Rail. Output 100Hz ripple (LHS, 5ms/div and 10mV/div) and 132kHz noise (RHS, 5us/div and 10mV/div)

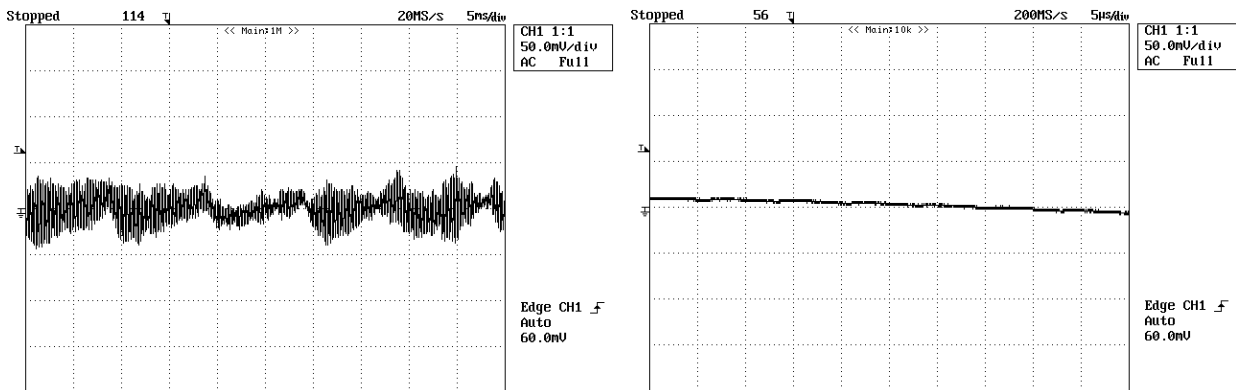

Figure 38 – 6V6 Rail. Output 100Hz ripple (LHS, 5ms/div and 50mV/div) and 132kHz noise (RHS, 5us/div and 50mV/div)

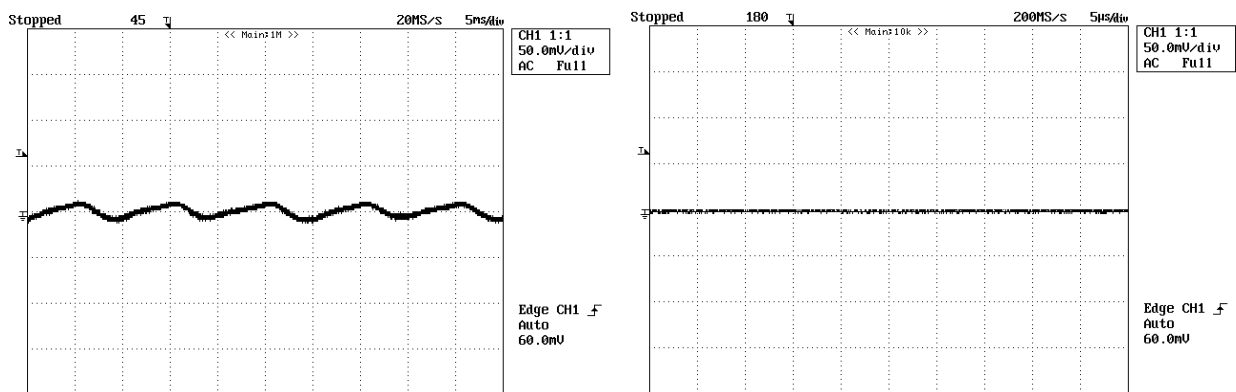

Figure 39 – 12V Rail. Output 100Hz ripple (LHS, 5ms/div and 50mV/div) and 132kHz noise (RHS, 5us/div and 50mV/div)



9.2.7 Conducted EMI Measurements

The measurements presented in this section are pre-compliance and should only be used for guidance. Measurements are performed with 115V input and full power output. Figure 41 gives the conducted EMI measurement with the output floating and Figure 42 with the output grounded to protective earth to simulate grounding through a SCART lead.

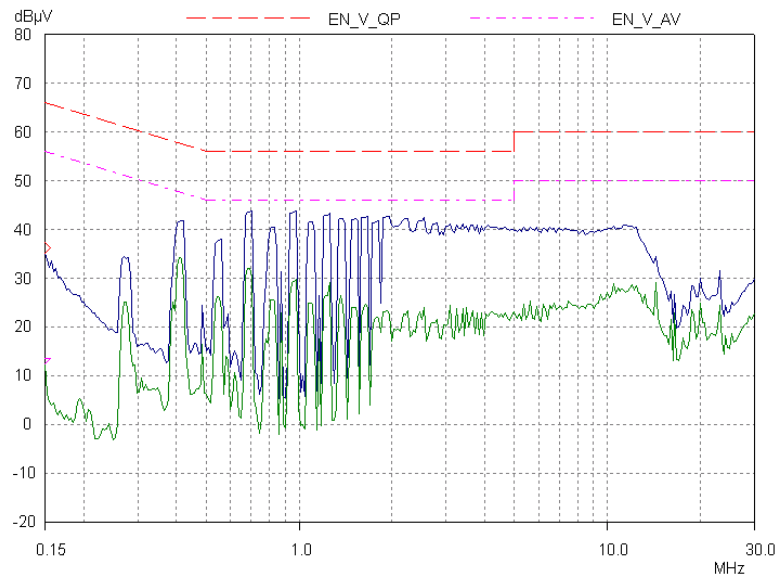

Figure 41 - EMI with Output Floating

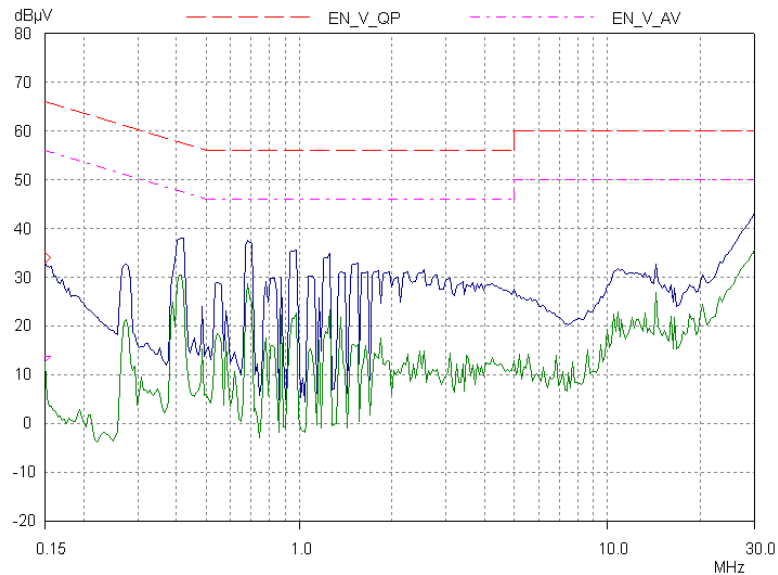

Figure 42 - EMI with Output Grounded to Protective Earth



10 Appendix A – Tolerance of Linear Regulated Outputs

10.1 2V5 Linear Regulated Output

The 2V5 output is provided via a diode drop from the 3V3 rail. The diode forward voltage will be a function of both diode current and temperature.

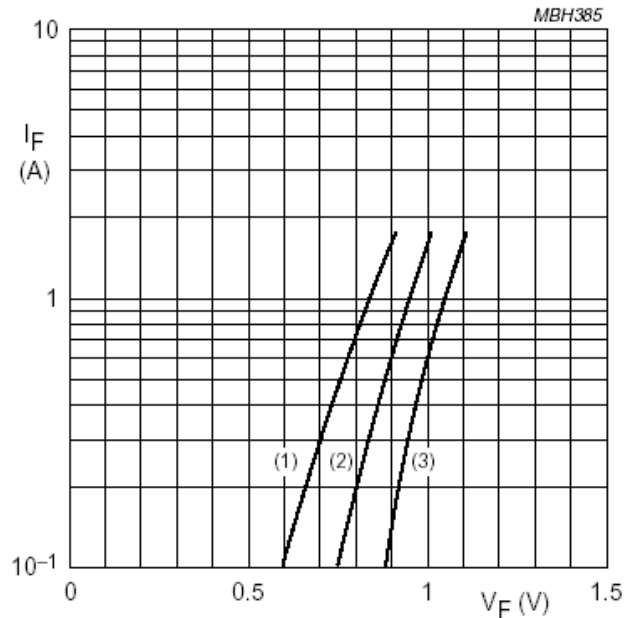

- (1) $T_{amb} = 100\text{ }^{\circ}\text{C}$.
- (2) $T_{amb} = 20\text{ }^{\circ}\text{C}$.
- (3) $T_{amb} = -50\text{ }^{\circ}\text{C}$.

Figure 43 – 1N4005 Diode Forward Voltage Behavior [Source - Philips Semiconductors]

The load current will vary from 30mA to 215mA and this will give a variation in diode drop of 0.7V to around 0.8V respectively. At 215mA and 20°C, the required 0.8V drop will be achieved giving 2.5V output.

With an operating ambient of 0-50°C, the likely diode temperature will be between 50°C and 100°C and therefore the voltage-current curve will lie between lines 1 and 2 on Figure 43.



10.2 1V2 Discrete Linear Regulator

The 1V2 linear regulator uses the circuit shown below to drop to 1.2V from 3.3V.

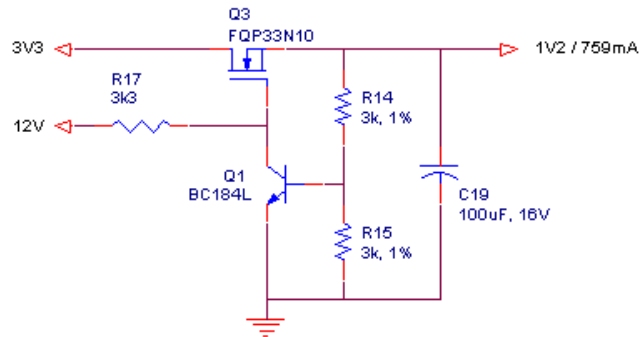

Figure 44 - 1V2 Discrete Linear Regulator

This circuit uses the base-emitter (V_{be}) voltage of Q1 to set the output voltage via R15 and R14. V_{be} is determined by the device temperature and the collector bias current. Pspice was used to simulate the variation of base-emitter voltage with collector current at 0, 25 and 50°C. The results are given in Figure 45 below.

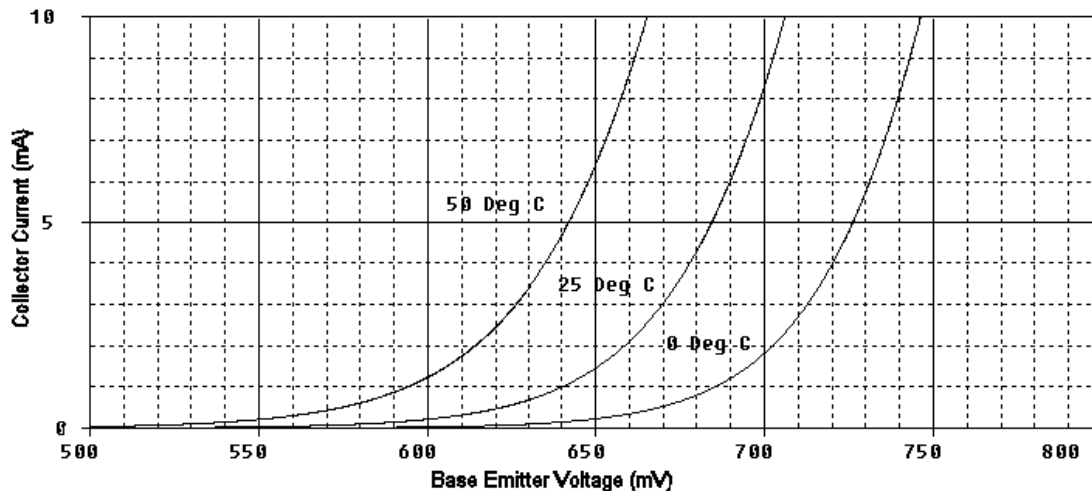

Figure 45 - Simulation of base-emitter voltage variation

Collector current in Q1 can be found from -
$$I_C = \frac{V_{Bias} - (V_{GS} + 1.2)}{R_{17}}$$

V_{BIAS} = Bias Voltage for Regulator (6.6V nominal here)

V_{GS} = Gate-Source voltage of Q3

Therefore, the collector current will vary with V_{BIAS} , V_{GS} and R_{17} . Differentiation of the I_C expression with respect to each of the three quantities will give the dependency.



$$\frac{dI_C}{dV_{BIAS}} = \frac{1}{R_{17}}, \quad \frac{dI_C}{dV_{GS}} = -\frac{1}{R_{17}} \quad \text{and} \quad \frac{dI_C}{dR_{17}} = \frac{-(V_{BIAS} - (V_{GS} + 1.2))}{(R_{17})^2}$$

With the values chosen,

$$\frac{dI_C}{dV_{BIAS}} = 0.3\text{mA/V}$$

$$\frac{dI_C}{dV_{GS}} = -0.3\text{mA/V}$$

$$\frac{dI_C}{dR_{17}} = -0.6\mu\text{A/V}$$

Thus, the two dominant mechanisms affecting the 1.2V output are variations in the regulator bias voltage (12V) and variations in the Gate-Source voltage of Q3. The bias voltage tolerance is 10% and this will give $\pm 0.36\text{mA}$ variation in collector current. The gate-source voltage behaviour of Q3 is shown below.

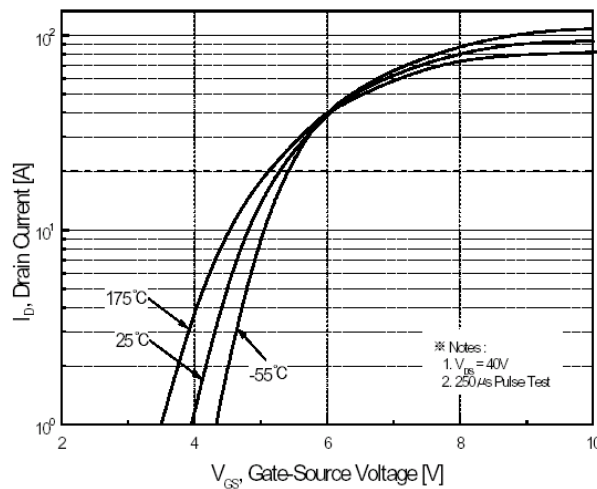

Figure 46 - Gate-Source Voltage Behaviour of QFP33N10

Figure 46 indicates that the gate-source voltage will vary by a maximum of around 0.5V over variations in temperature and drain current (0 to 1A). Thus, variations in the collector current of Q1 due to changes in the gate-source voltage of Q3 will be around $\pm 0.15\text{mA}$. The combined changes in collector current will be $\pm 0.45\text{mA}$ and this will have a very small effect on output voltage. Temperature changes will influence V_{BE} to a greater effect and Figure 45 shows V_{BE} changes from 715mV at 0°C and 2mA to 615mV at 50°C and 2mA. This gives an output voltage from the linear regulator circuit of 1.3V at 0°C and 1.12V at 50°C.



11 Revision History

Date	Author	Revision	Description & changes	Reviewed
March 30, 2004	IM	1.0	Initial release	VC / AM



For the latest updates, visit our Web site: www.powerint.com

Power Integrations reserves the right to make changes to its products at any time to improve reliability or manufacturability. Power Integrations does not assume any liability arising from the use of any device or circuit described herein, nor does it convey any license under its patent rights or the rights of others.

The products and applications illustrated herein (including circuits external to the products and transformer construction) may be covered by one or more U.S. and foreign patents or potentially by pending U.S. and foreign patent applications assigned to Power Integrations. A complete list of Power Integrations' patents may be found at www.powerint.com.

The PI Logo, **TOPSwitch**, **TinySwitch**, **LinkSwitch**, and **EcoSmart** are registered trademarks of Power Integrations. **PI Expert** and **DPA-Switch** are trademarks of Power Integrations.
© Copyright 2003, Power Integrations.

WORLD HEADQUARTERS

Power Integrations
5245 Hellyer Avenue,
San Jose, CA 95138, USA
Main: +1-408-414-9200
Customer Service:
Phone: +1-408-414-9665
Fax: +1-408-414-9765
e-mail:
usasales@powerint.com

AMERICAS

Power Integrations, Inc.
4335 South Lee Street,
Suite G,
Buford, GA 30518, USA
Phone: +1-678-714-6033
Fax: +1-678-714-6012
e-mail:
usasales@powerint.com

CHINA (SHANGHAI)

Power Integrations
International Holdings, Inc.
Rm 807, Pacheer,
Commercial Centre,
555 Nanjing West Road,
Shanghai, 200041, China
Phone: +86-21-6215-5548
Fax: +86-21-6215-2468
e-mail:
chinasales@powerint.com

APPLICATIONS HOTLINE

World Wide +1-408-414-9660

CHINA (SHENZHEN)

Power Integrations
International Holdings, Inc.
Rm# 1705, Bao Hua Bldg.
1016 Hua Qiang Bei Lu,
Shenzhen, Guangdong,
518031, China
Phone: +86-755-8367-5143
Fax: +86-755-8377-9610
e-mail: chinasales@powerint.com

GERMANY

Power Integrations, GmbH
Rueckerstrasse 3,
D-80336, Munich, Germany
Phone: +49-895-527-3910
Fax: +49-895-527-3920
e-mail: eurossales@powerint.com

INDIA (TECHNICAL SUPPORT)

Innovatech
261/A, Ground Floor
7th Main, 17th Cross,
Sadashivanagar
Bangalore, India, 560080
Phone: +91-80-5113-8020
Fax: +91-80-5113-8023
e-mail: indiasales@powerint.com

APPLICATIONS FAX

World Wide +1-408-414-9760

ITALY

Power Integrations s.r.l.
Via Vittorio Veneto 12,
Bresso, Milano,
20091, Italy
Phone: +39-028-928-6001
Fax: +39-028-928-6009
e-mail:
eurossales@powerint.com

JAPAN

Power Integrations, K.K.
Keihin-Tatemono 1st Bldg.
12-20 Shin-Yokohama,
2-Chome,
Kohoku-ku, Yokohama-shi,
Kanagawa 222-0033, Japan
Phone: +81-45-471-1021
Fax: +81-45-471-3717
e-mail:
japansales@powerint.com

KOREA

Power Integrations
International Holdings, Inc.
8th Floor, DongSung Bldg.
17-8 Yoido-dong,
Youngdeungpo-gu,
Seoul, 150-874, Korea
Phone: +82-2-782-2840
Fax: +82-2-782-4427
e-mail:
koreasales@powerint.com

SINGAPORE (ASIA PACIFIC HEADQUARTERS)

Power Integrations, Singapore
51 Newton Road,
#15-08/10 Goldhill Plaza,
Singapore, 308900
Phone: +65-6358-2160
Fax: +65-6358-2015
e-mail:
singaporesales@powerint.com

TAIWAN

Power Integrations
International Holdings, Inc.
17F-3, No. 510,
Chung Hsiao E. Rd., Sec. 5,
Taipei, Taiwan 110, R.O.C.
Phone: +886-2-2727-1221
Fax: +886-2-2727-1223
e-mail:
taiwansales@powerint.com

UK (EUROPE & AFRICA HEADQUARTERS)

1st Floor, St. James's House
East Street
Farnham, Surrey GU9 7TJ
United Kingdom
Phone: +44-1252-730-140
Fax: +44-1252-727-689
e-mail: eurossales@powerint.com

