



Design Example Report

Title	<i>9.1 W LED Driver Buck Converter Using LNK306PN</i>
Specification	108 VAC – 132 VAC Input, 70 V, 130 mA Output
Application	LED Arrays
Author	Applications Engineering Department
Document Number	DER-172
Date	April 28, 2008
Revision	1.4

Summary and Features

- Constant current (CC) supply ideal for driving LEDs
- Very high efficiency (>90%) throughout operating range
- Compact, lightweight, inexpensive, low part-count design
- Simple inductor design
- Meets EN55022B limits for conducted EMI with greater than 10 dB margin.

PATENT INFORMATION

The products and applications illustrated herein (including transformer construction and circuits external to the products) may be covered by one or more U.S. and foreign patents, or potentially by pending U.S. and foreign patent applications assigned to Power Integrations. A complete list of Power Integrations' patents may be found at www.powerint.com. Power Integrations grants its customers a license under certain patent rights as set forth at <http://www.powerint.com/ip.htm>.

Power Integrations

5245 Hellyer Avenue, San Jose, CA 95138 USA.

Tel: +1 408 414 9200 Fax: +1 408 414 9201

www.powerint.com

Table of Contents

1	Introduction.....	3
2	Power Supply Specification	4
3	Schematic.....	5
4	Circuit Description	6
4.1	Introduction.....	6
4.2	AC Input and EMI Filter	6
4.3	General Operation.....	6
4.4	Device Operation and Feedback Circuit.....	6
5	PCB Layout	7
6	Bill of Materials	8
7	Inductor Specification	9
7.1	Electrical Diagram	9
7.2	Electrical Specifications.....	9
7.3	Materials.....	9
7.4	Transformer Build Diagram	10
7.5	Transformer Construction.....	10
8	Design Spreadsheet	11
9	Performance Data	13
9.1	Output Characteristic.....	13
9.2	Efficiency.....	13
9.3	No-load Input Power.....	14
9.4	Regulation	14
9.4.1	Line	14
10	Thermal Performance	15
11	Waveforms.....	16
11.1	Drain Voltage and Current, Normal Operation.....	16
11.2	Output Voltage Start-up Profile.....	16
11.3	Drain Voltage and Current Start-up Profile	17
11.4	Output Ripple Measurements.....	18
11.4.1	Ripple Measurement Technique	18
11.4.2	Measurement Results	19
12	Conducted EMI	20
13	Revision History	21

Important Note:

Although this board is designed to satisfy safety isolation requirements, the engineering prototype has not been agency approved. Therefore, all testing should be performed using an isolation transformer to provide the AC input to the prototype board.



1 Introduction

This engineering report describes a power supply utilizing the LinkSwitch-TN device LNK306PN in a buck-converter topology.

This power supply operates using input voltages ranging from 108 to 132 VAC. This ensures a DC bus voltage large enough to support a 70 V output. In a buck topology the output voltage is always smaller than the input voltage. The output voltage is limited by the maximum duty cycle of the LinkSwitch-TN, requiring the input voltage to be sufficiently larger than the required output voltage.

This particular design requires a minimum of 108 VAC input. This circuit utilizes a 22 μ F DC bus filter capacitance which ensures the required output level given the constraints of the LNK306PN's duty cycle. To use a truly universal input range (90 to 132 VAC) either reduce the output voltage to 60 V or change the value of the input capacitor C2 to 68 μ F.

This document contains the power supply specifications, schematic, bill of materials, inductor specifications, printed circuit layout, and performance data for the design.



Figure 1 – Populated Circuit Board Photograph.

2 Power Supply Specification

Description	Symbol	Min	Typ	Max	Units	Comment
Input						
Voltage	V_{IN}	108	115	132	VAC	2 Wire – no P.E.
Frequency	f_{LINE}	50	60	64	Hz	
No-load Input Power (132 VAC)				1	W	
Output						
Output Current 1	I_{OUT1}		130		mA	20 MHz bandwidth Overvoltage Protection
Output Ripple Voltage 1	$V_{RIPPLE1}$			375	mV	
Output Voltage 1	V_{OUT1}		70	85	V	
Total Output Power						
Continuous Output Power	P_{OUT}		9.1		W	
Efficiency						
Full Load	η	92			%	Measured at P_{OUT} 25 °C
Environmental						
Conducted EMI		Meets CISPR22B / EN55022B				
Safety		Designed to meet IEC950 / UL1950 Class II				
Ambient Temperature	T_{AMB}	0		50	°C	Free convection, sea level



3 Schematic

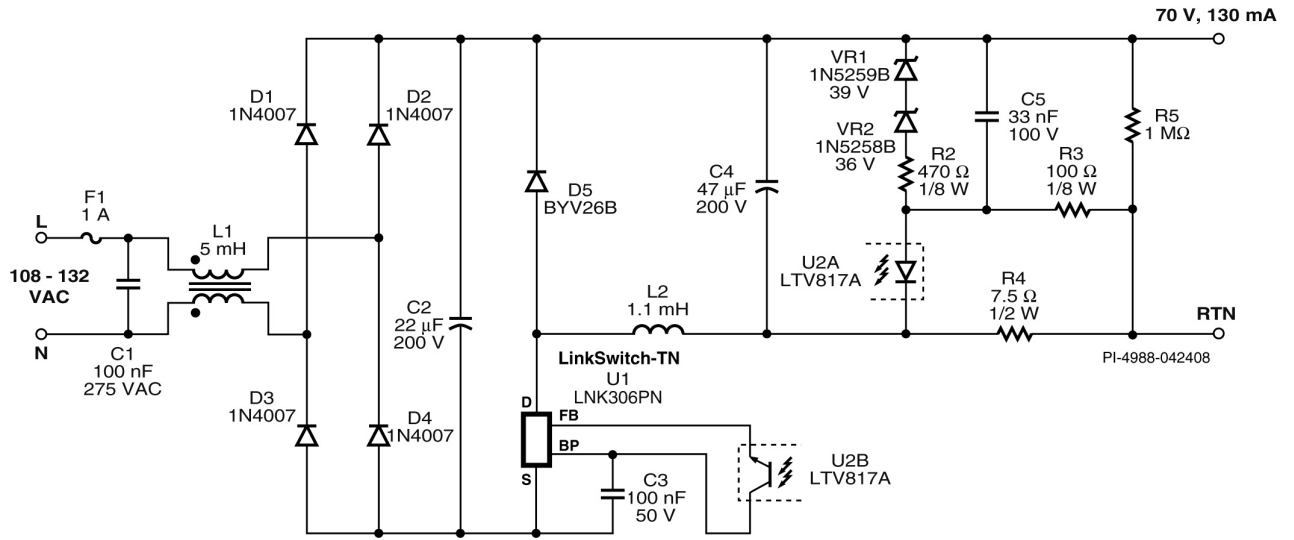

Figure 2 – Schematic.



4 Circuit Description

4.1 Introduction

The power supply shown in Figure 2 uses the LNK306PN (U1) in a low-side buck configuration to deliver a constant 130 mA current at a voltage of 70 VDC. The supply is optimal for driving LEDs, which should always be driven with a constant current (CC) rather than a constant voltage (CV) source.

4.2 AC Input and EMI Filter

Fuse F1 provides short circuit protection against catastrophic failures. Capacitor C1 and common-mode choke L1 reduce conducted EMI. Diodes D1 through D4 provide full wave rectification while high-voltage capacitor C2 maintains a steady DC bus voltage.

4.3 General Operation

During U1's on time, current flows through capacitor C4, the load (a 70 V LED string), and inductor L2. This current flow results in energy stored in L2 as well as energy delivered to the load.

During U1's off time, the polarity of L2 reverses in an attempt to maintain the current flow. This polarity reversal forward biases the freewheeling diode D5, allowing current to flow through inductor L2, and energy to be continually delivered to C4 and the load.

4.4 Device Operation and Feedback Circuit

Output regulation is maintained by U1's On/Off control scheme whereby switching cycles are enabled and disabled (skipped) in response to changing line and load conditions. The transistor of optocoupler U2 delivers current to U1's feedback (FB) pin. This current is sampled during each clock cycle, on the rising edge of the internal clock of U1. If the current is greater than 49 μ A an entire switching cycle is skipped. C3 is the bypass capacitor for U1.

Resistor R4 acts as a current-sensing resistor. The voltage across R4 appears across resistor R3 and optocoupler diode U2A. R3 sets the DC gain of the feedback loop. Zener diodes VR1 and VR2 clamp the output voltage to a maximum of approximately 75 V. Capacitor C5 reduces noise sensitivity and improves response time of the feedback loop. Resistor R5 acts as a bleed resistor to high-voltage output capacitor C4 (needed when the LED load is removed).



5 PCB Layout

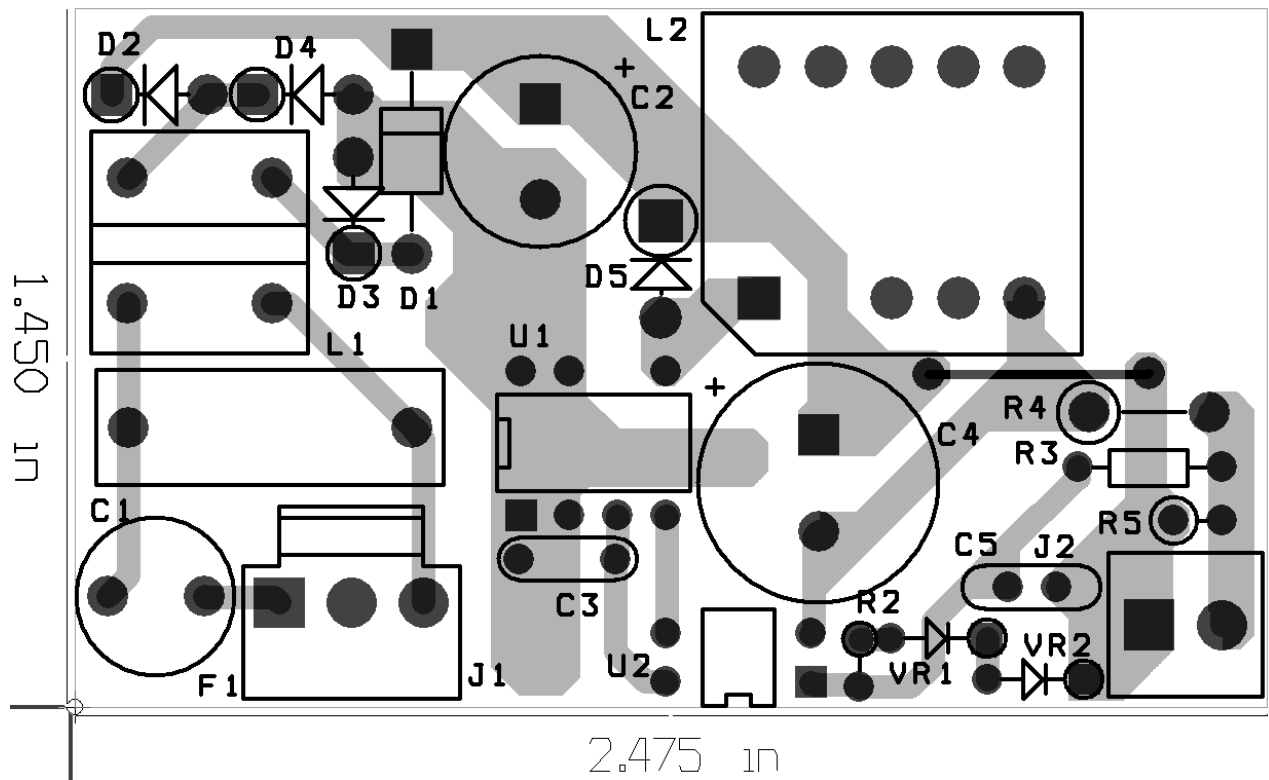

Figure 3 – Printed Circuit Layout.



6 Bill of Materials

Item	Qty	Ref.	Description	P/N	Manufacturer
1	1	C1	100 nF, 275 VAC, Film, X2	ECQ-U2A104ML	Panasonic
2	1	C2	22 μ F, 200 V, Electrolytic, High Ripple, (10 x 20)	EEUEB2D220	Panasonic
3	1	C3	100 nF, 50 V, Ceramic, Z5U, .2Lead Space	C317C104M5U5TA	Kemet
4	1	C4	47 μ F, 200 V, Electrolytic, High Ripple, (12.5 x 20)	EEUEB2D470	Panasonic
5	1	C5	33 nF, 100 V, Ceramic, X7R	B37987M1333K000	Epcos
6	4	D1 D2 D3 D4	1000 V, 1 A, Rectifier, DO-41	1N4007	Vishay
7	1	D5	400 V, 1 A, Ultrafast Recovery, 30 ns, SOD57	BYV26B	Philips
8	1	F1	1 A, 250V, Slow, TR5	3721100041	Wickman
9	1	J1	3 Position (1 x 3) header, 0.156 pitch, Vertical	26-48-1031	Molex
10	1	J2	2 Position (1 x 2) header, 0.156 pitch, Vertical	26-48-1021	Molex
11	1	L1	5 mH, 0.3 A, Common Mode Choke	SU9V-03050	Token
12	1	L2	1.1 mH, wound on a EE19 bobbin		Custom
13	1	R2	470 Ω , 5%, 1/8 W, Carbon Film	CFR-12JB-470R	Yageo
14	1	R3	100 Ω , 5%, 1/8 W, Carbon Film	CFR-12JB-100R	Yageo
15	1	R4	7.5 Ω , 5%, 1/2 W, Carbon Film	CFR-50JB-7R5	Yageo
16	1	R5	1 M Ω , 5%, 1/4 W, Carbon Film	CFR-25JB-1M0	Yageo
17	1	U1	LinkSwitch-TN, LNK306PN, DIP-8B	LNK306PN	Power Integrations
18	1	U2	Opto coupler, 35 V, CTR 80-160%, 4-DIP	LTV-817A	Liteon
19	1	VR1	39 V, 5%, 500 mW, DO-35	1N5259B	Microsemi
20	1	VR2	36 V, 5%, 500 mW, DO-35	1N5258B	Microsemi



7 Inductor Specification

7.1 Electrical Diagram



Figure 4 – Inductor Electrical Diagram.

7.2 Electrical Specifications

Electrical Strength	1 second, 60 Hz, from Pin 1 to Pin 5	3000 VAC
Primary Inductance	Pins 1-5, all other windings open, measured at 100 kHz, 0.4 VRMS.	1.1 mH, $\pm 10\%$

7.3 Materials

Item	Description
[1]	Core: TDK PC40EE19-Z, or equivalent Gap for AL of 107.8 nH/T ² .
[2]	Bobbin: EE19 Vertical 10 pin Yih Hwa YW-047 or equivalent.
[3]	Magnet Wire: #27 AWG, Solderable, double-coated.
[4]	Tape: Polyester Film, 3M 1298 or Equivalent, 9.0 mm wide.

7.4 Inductor Build Diagram

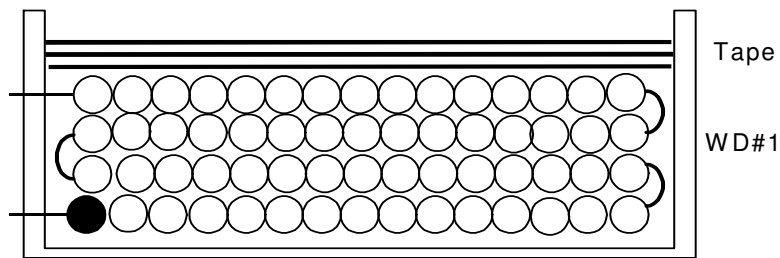

Figure 5 – Inductor Build Diagram.

7.5 Inductor Construction

Bobbin Preparation	Pull Pin 2 on bobbin [2]. Bobbin pinout is shown in layout.
Primary	Start at Pin 5. Wind 110 turns of item [3]. Finish the winding on Pin 1.
Insulation	Use three layers of item [4] for safety insulation.
Final Assembly	Gap core to achieve an inductance of 1.1 mH \pm 10 %. Assemble and secure core halves.



8 Design Spreadsheet

The PIXIs tool was used to help design this supply. Results are shown below.

ACDC_LinkSwitch-TN_041607; Rev.2.6; Copyright Power Integrations 2007	INPUT	INFO	OUTPUT	UNIT	LinkSwitch-TN_Rev_2-6.xls: LinkSwitch-TN Design Spreadsheet
INPUT VARIABLES					Customer
VACMIN	108			Volts	Minimum AC Input Voltage
VACMAX	132			Volts	Maximum AC Input Voltage
FL	50			Hertz	Line Frequency
VO	70.00			Volts	Output Voltage
IO	0.130			Amps	Output Current
EFFICIENCY (User Estimate)	0.92				Overall Efficiency Estimate (Adjust to match Calculated, or enter Measured Efficiency)
EFFICIENCY (Calculated Estimate)			0.93		Calculated % Efficiency Estimate
CIN	22.00		22.00	uF	Input Filter Capacitor
Input Stage Resistance			0.00	ohms	Input Stage Resistance, Fuse & Filtering
Ambient Temperature			50	deg C	Operating Ambient Temperature (deg Celsius)
Switching Topology			Buck		Type of Switching topology
Input Rectification Type	F		F		Choose H for Half Wave Rectifier and F for Full Wave Rectification
DC INPUT VARIABLES					
VMIN			130.5	Volts	Minimum DC Bus Voltage
VMAX			186.7	Volts	Maximum DC Bus Voltage
LinkSwitch-TN					
LinkSwitch-TN	LNK306		LNK306		Selected LinkSwitch-TN. Ordering info - Suffix P/G indicates DIP 8 package; suffix D indicates SO8 package; second suffix N indicates lead free RoHS compliance
ILIMIT			0.482	Amps	Typical Current Limit
ILIMIT_MIN			0.450	Amps	Minimum Current Limit
ILIMIT_MAX			0.515	Amps	Maximum Current Limit
FSMIN			62000	Hertz	Minimum Switching Frequency
VDS			6.2	Volts	Maximum On-State Drain To Source Voltage drop
PLOSS_LNK			0.41	Watts	Estimated LinkSwitch-TN losses
DIODE					
VD			0.70	Volts	Freewheeling Diode Forward Voltage Drop
VRR			400	Volts	Recommended PIV rating of Freewheeling Diode
IF			1	Amps	Recommended Diode Continuous Current Rating
TRR			75	ns	Recommended Reverse Recovery Time
Diode Recommendation			UF4005		Suggested Freewheeling Diode
OUTPUT INDUCTOR					
L_TYP			880.2	uH	Required value of Inductance to deliver Output Power (Includes device and inductor tolerances) Choose next higher standard available value
L	1100		1100	uH	Output Inductor, Recommended Standard Value
L_R			2.0	Ohms	DC Resistance of Inductor
OPERATING MODE			MDCM		Mostly Discontinuous Conduction Mode (at VMIN)
KL_TOL	1.10		1.10		Inductor tolerance Factor. Accounts for basic (10% - 20%) Manufacturing Tolerances 1.1 < KL_TOL < 1.2 See AN-37 for detailed explanation
K_LOSS			0.947		Loss factor. Accounts for "off-state" power loss to be supplied by



					inductor Calculated efficiency < K_LOSS < 1. See AN-37 for detailed explanation
ILRMS		0.20	Amps		Estimated RMS inductor current (at VMAX)
OUTPUT CAPACITOR					
DELTA_V		0.70	Volts		Target Output Voltage Ripple
MAX_ESR		1556	m-Ohms		Maximum Capacitor ESR (milli-ohms)
I RIPPLE		0.45	Amps		Output Capacitor Ripple current
FEEDBACK COMPONENTS					
RBIAS		2.00	k-Ohms		Bias Resistor. Use closest standard 1% value
RFB		78.29	k-Ohms		Feedback Resistor. Use closest standard 1% value
CFB		10	uF		Feedback Capacitor
C_SOFT_START		1 - 10	uF		If the output Voltage is greater than 12 V, or total output and system capacitance is greater than 100 uF, a soft start capacitor between 1uF and 10 uF is recommended. See AN-37 for details



9 Performance Data

All measurements performed at room temperature, 60 Hz input frequency.

9.1 Output Characteristic

The output characteristic was obtained by removing one LED at a time from the series string (which acted as the load).

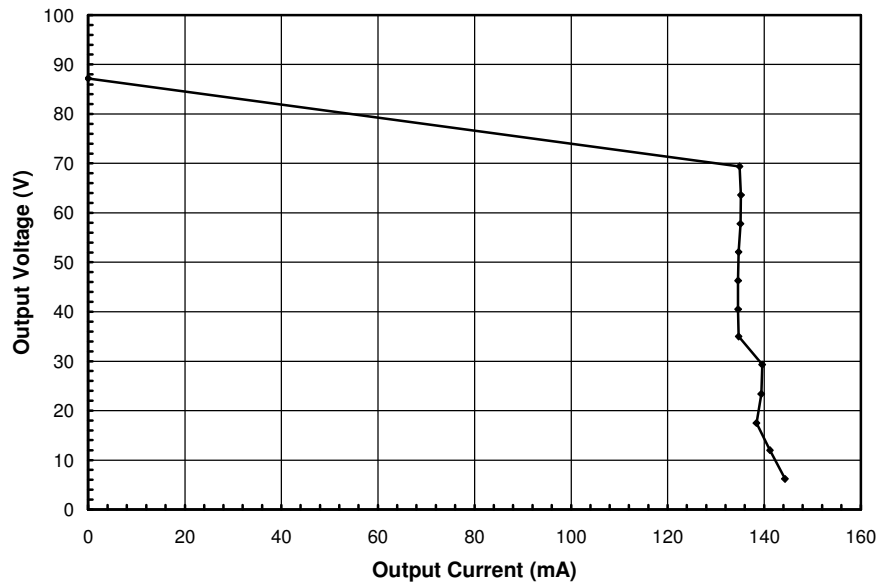

Figure 6 – Output characteristic, 115 VAC.

9.2 Efficiency

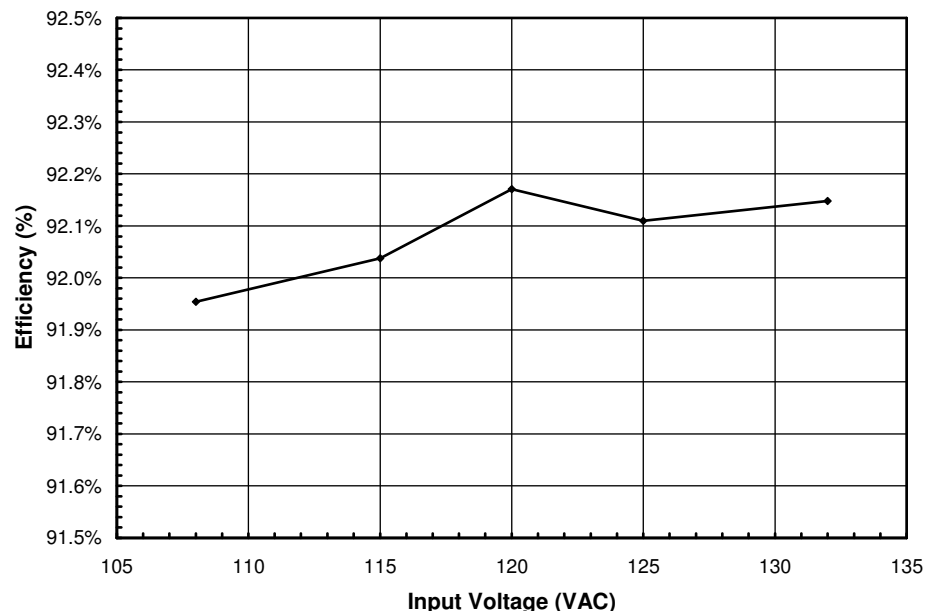

Figure 7 – Efficiency vs. Input Voltage.



9.3 No-load Input Power

The no-load input power is high due to the fact that the OVP circuit formed by VR1 and VR2 consumes close to 400 mW of biasing power.

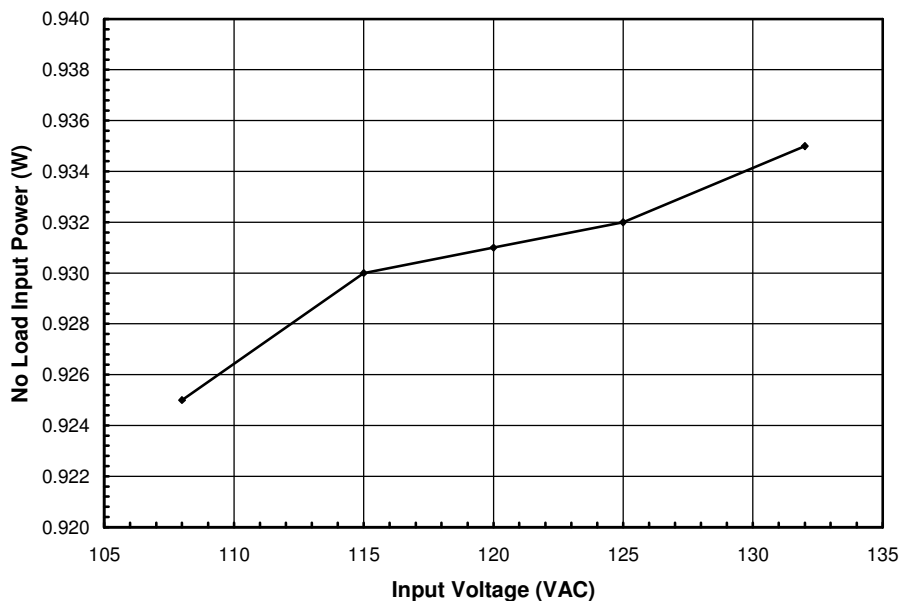

Figure 8 – Zero Load Input Power vs. Input Line Voltage.

9.4 Regulation

9.4.1 Line

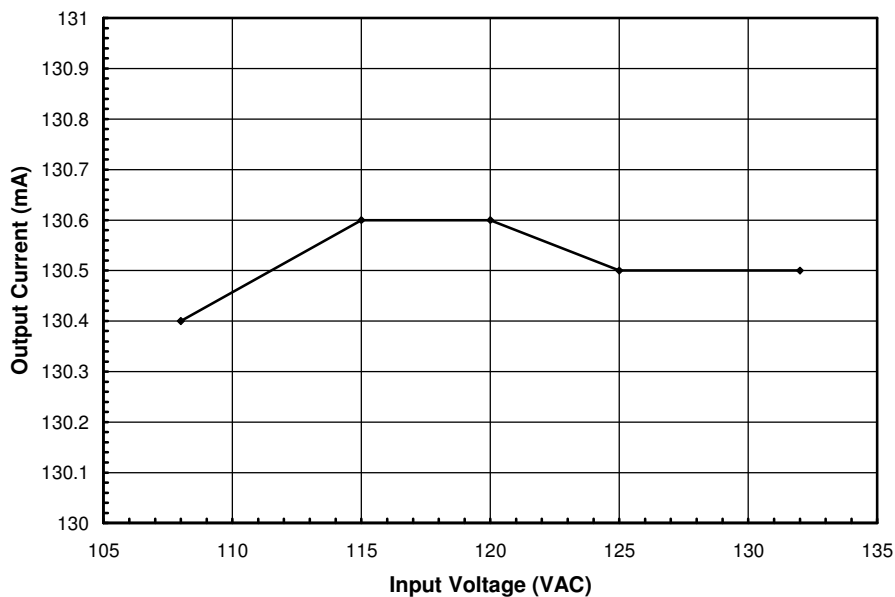

Figure 9 – Line Regulation, Room Temperature, Full Load.



10 Thermal Performance

The temperatures of four components were measured at room temperature, using separate thermocouples on each, to ensure acceptable thermal performance. The supply was placed in a cardboard box to prevent convective cooling by air currents in the room. A T-type thermocouple was soldered to U1's source pin, near its plastic casing, to measure its temperature. The temperature of D5 was measured by soldering a T-type thermocouple to the anode lead near its case. The transformer (T1) winding temperature was measured with a T-type thermocouple taped to the outermost tape layer of the transformer windings. The temperature of C2 was measured at the top of its case.

Item	Temperature (°C)
	108 VAC
Ambient	29
LNK306PN (U1)	41
Freewheeling Diode (D5)	40
Transformer Windings (T1)	35
Top of Input Capacitor (C2)	35



11 Waveforms

All waveforms were taken at room temperature, 60 Hz line frequency with a series LED load.

11.1 Drain Voltage and Current, Normal Operation

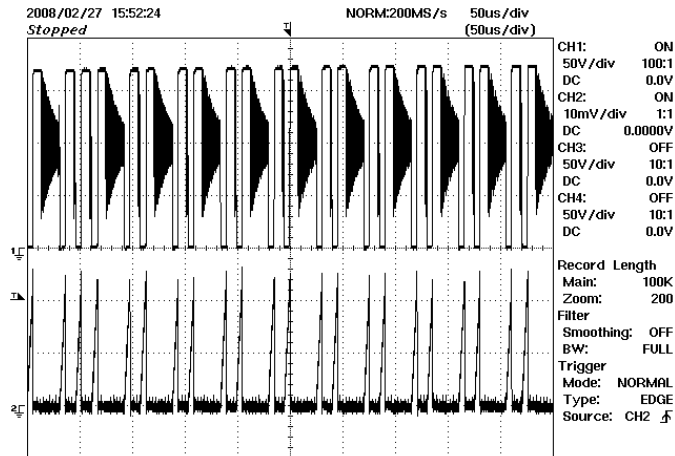

Figure 10 – 108 VAC, Full Load.

Upper: V_{DRAIN} , 50 V, 50 μ s / div.
Lower: I_{DRAIN} , 0.2 A / div.

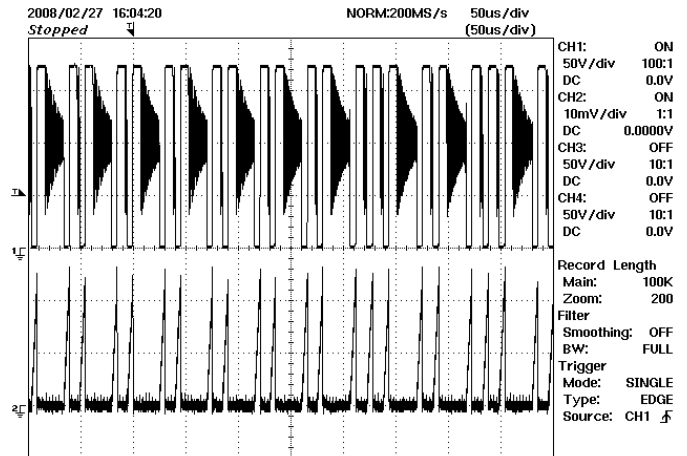

Figure 11 – 132 VAC, Full Load.

Upper: V_{DRAIN} , 50 V, 50 μ s / div.
Lower: I_{DRAIN} , 0.2 A / div.

11.2 Output Voltage Start-up Profile

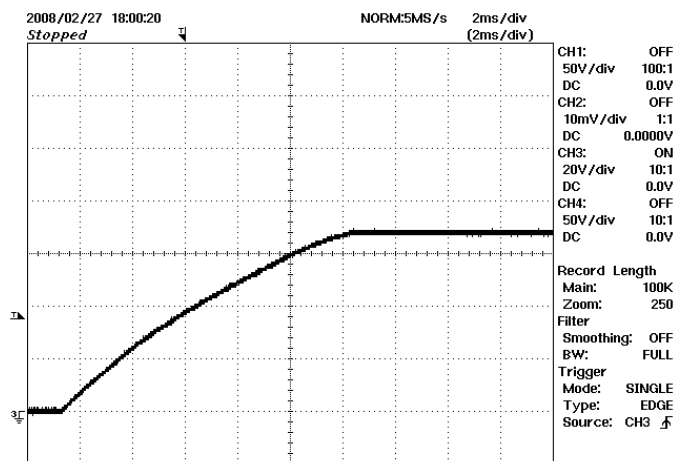

Figure 12 – 108 VAC Start-up Profile
20 V / div, 2 ms / div.

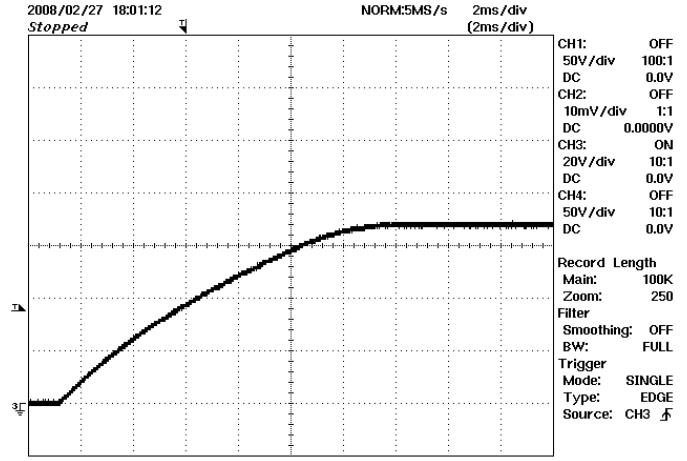

Figure 13 – 132 VAC Start-up Profile
20 V, 2 ms / div.



11.3 Drain Voltage and Current Start-up Profile

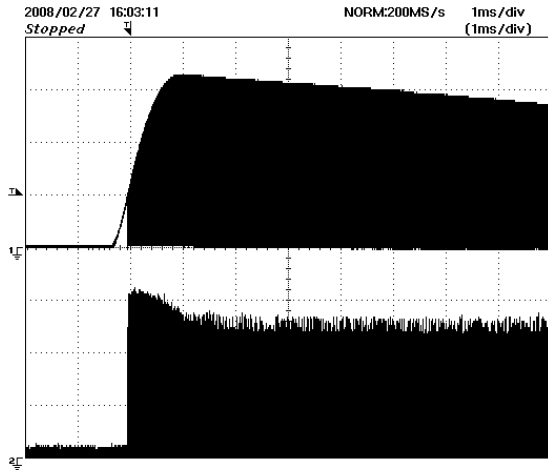

Figure 14 – 108 VAC Input and Maximum Load.
Upper: I_{DRAIN} , 0.2 A / div.
Lower: V_{DRAIN} , 50 V, 1 ms / div.

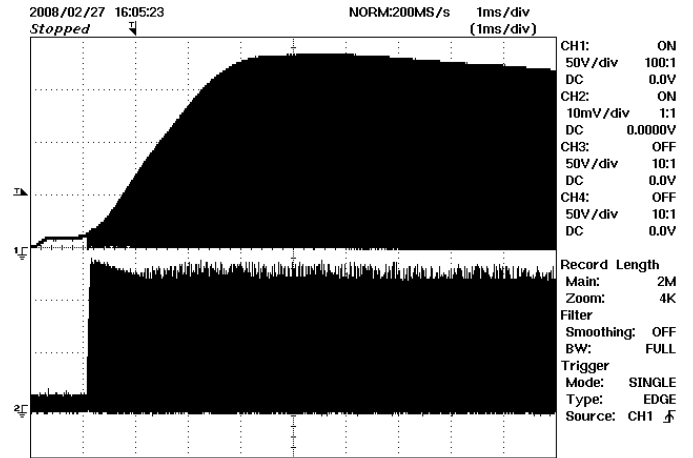

Figure 15 – 132 VAC Input and Maximum Load.
Upper: I_{DRAIN} , 0.2 A / div.
Lower: V_{DRAIN} , 50 V, 1 ms / div.



11.4 Output Ripple Measurements

11.4.1 Ripple Measurement Technique

For DC output ripple measurements, use a modified oscilloscope test probe to reduce spurious signals. Details of the probe modification are provided in figures below.

Tie two capacitors in parallel across the probe tip of the 4987BA probe adapter. The capacitors include a 0.1 μF / 50 V ceramic type and 1.0 μF / 50 V aluminum electrolytic. The aluminum-electrolytic capacitor is polarized, so always maintain proper polarity across DC outputs. (Refer to Figure 16 and Figure 17.)

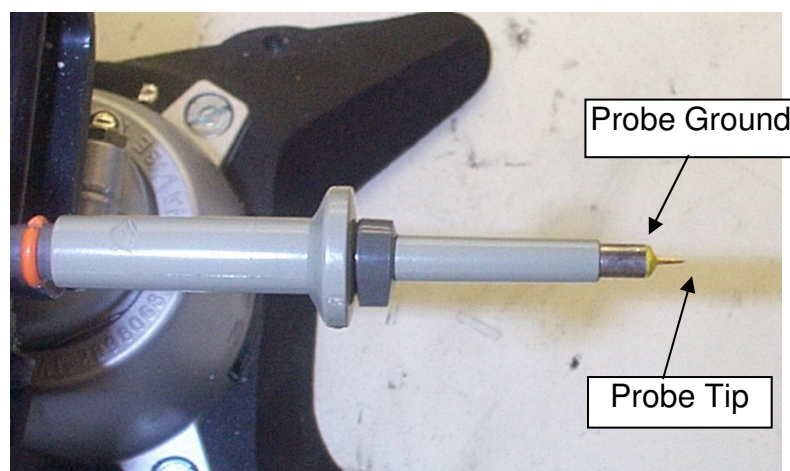

Figure 16 – Oscilloscope Probe Prepared for Ripple Measurement. (End Cap and Ground Lead Removed)

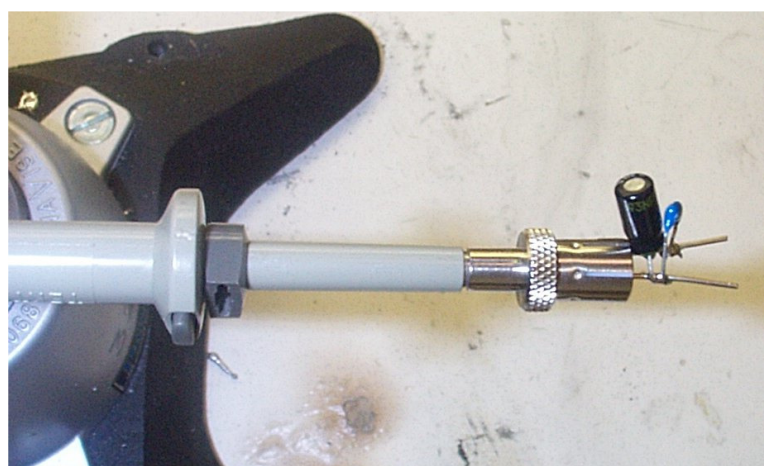

Figure 17 – Oscilloscope Probe with Probe Master (www.probemaster.com) 4987A BNC Adapter. (Modified with wires for ripple measurement, and two parallel decoupling capacitors added)

11.4.2 Measurement Results

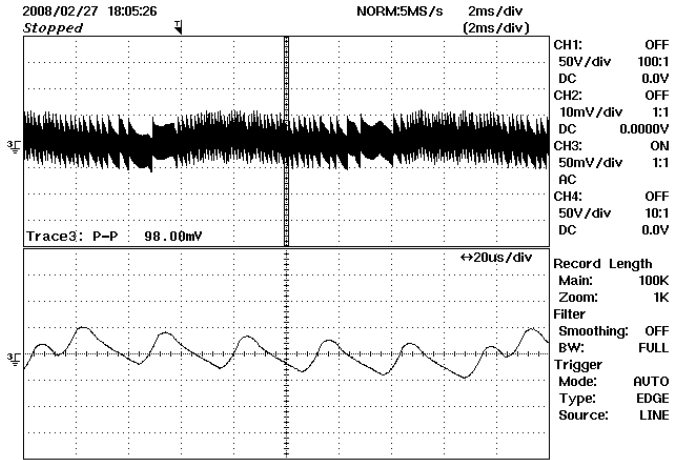

Figure 18 – Output Ripple, 108 VAC, Full Load.
2 ms, 50 mV / div.

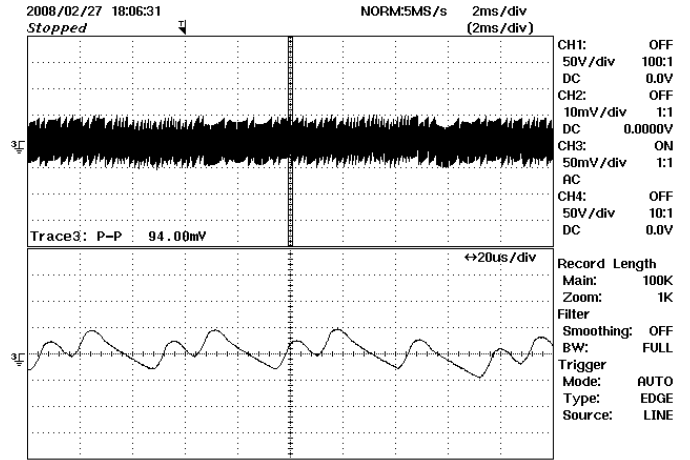

Figure 19 – Output Ripple, 132 VAC, Full Load.
2 ms, 50 mV / div.

12 Conducted EMI

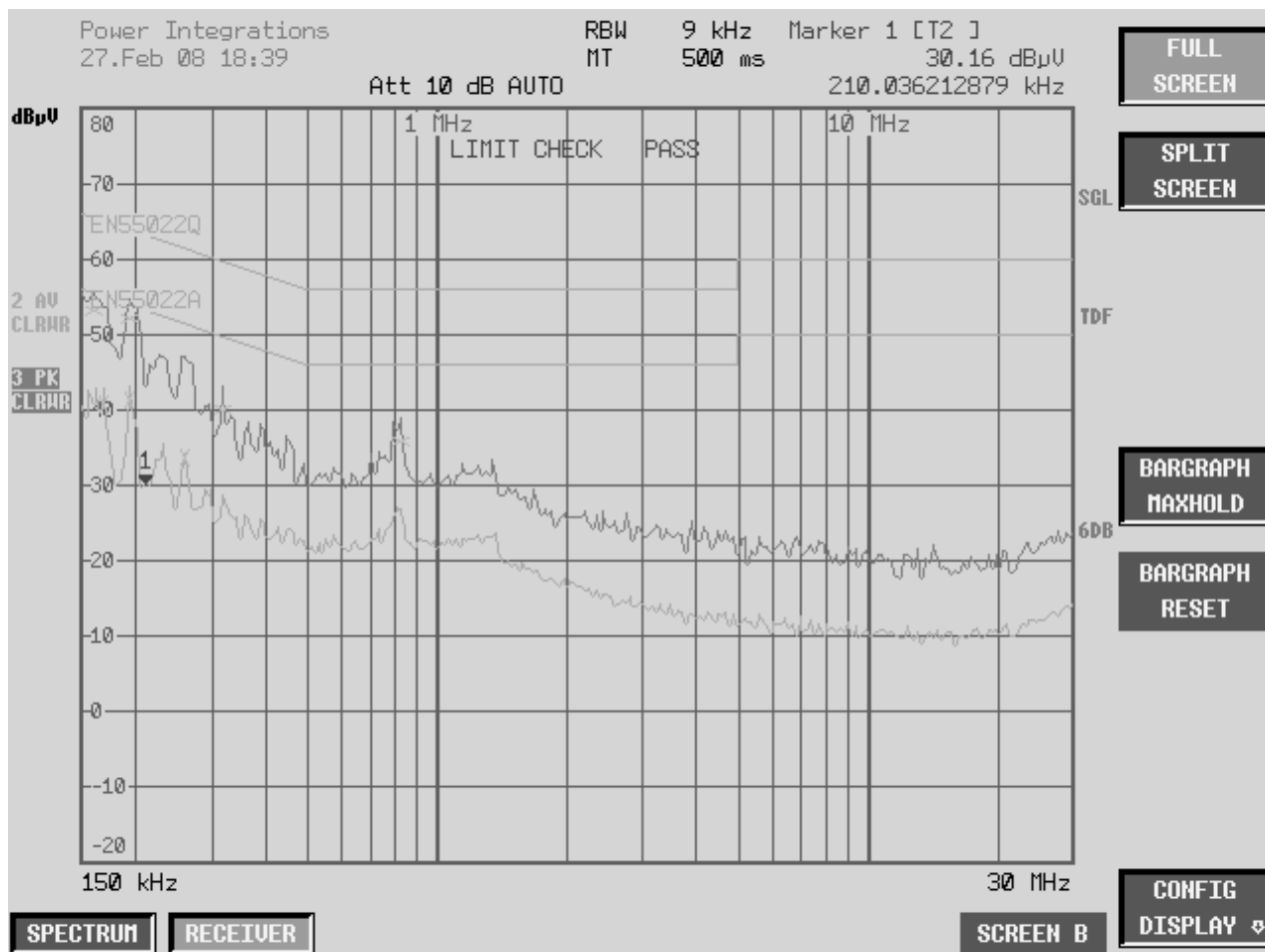

Figure 20 – Conducted EMI, Maximum Steady State Load, 115 VAC, 60 Hz, and EN55022 B Limits. Output Connected to Artificial Hand.

13 Revision History

Date	Author	Revision	Description & changes	Reviewed
28-Apr-08	SGK	1.4	Initial Release	JD



Notes



Notes



For the latest updates, visit our website: www.powerint.com

Power Integrations reserves the right to make changes to its products at any time to improve reliability or manufacturability. Power Integrations does not assume any liability arising from the use of any device or circuit described herein. POWER INTEGRATIONS MAKES NO WARRANTY HEREIN AND SPECIFICALLY DISCLAIMS ALL WARRANTIES INCLUDING, WITHOUT LIMITATION, THE IMPLIED WARRANTIES OF MERCHANTABILITY, FITNESS FOR A PARTICULAR PURPOSE, AND NON-INFRINGEMENT OF THIRD PARTY RIGHTS.

PATENT INFORMATION

The products and applications illustrated herein (including transformer construction and circuits external to the products) may be covered by one or more U.S. and foreign patents, or potentially by pending U.S. and foreign patent applications assigned to Power Integrations. A complete list of Power Integrations' patents may be found at www.powerint.com. Power Integrations grants its customers a license under certain patent rights as set forth at <http://www.powerint.com/ip.htm>.

The PI Logo, TOPSwitch, TinySwitch, LinkSwitch, DPA-Switch, PeakSwitch, EcoSmart, Clampless, E-Shield, Filterfuse, StackFET, PI Expert and PI FACTS are trademarks of Power Integrations, Inc. Other trademarks are property of their respective companies. ©Copyright 2008 Power Integrations, Inc.

Power Integrations Worldwide Sales Support Locations

WORLD HEADQUARTERS

5245 Hellyer Avenue
San Jose, CA 95138, USA.
Main: +1-408-414-9200
Customer Service:
Phone: +1-408-414-9665
Fax: +1-408-414-9765
e-mail: usasales@powerint.com

GERMANY

Rueckertstrasse 3
D-80336, Munich
Germany
Phone: +49-89-5527-3911
Fax: +49-89-5527-3920
e-mail: eurosales@powerint.com

JAPAN

Kosei Dai-3 Bldg.,
2-12-11, Shin-Yokohama,
Kohoku-ku, Yokohama-shi,
Kanagawa 222-0033
Phone: +81-45-471-1021
Fax: +81-45-471-3717
e-mail:
japansales@powerint.com

TAIWAN

5F, No. 318, Nei Hu Rd., Sec. 1
Nei Hu Dist.
Taipei, Taiwan 114, R.O.C.
Phone: +886-2-2659-4570
Fax: +886-2-2659-4550
e-mail:
taiwansales@powerint.com

CHINA (SHANGHAI)

Rm 1601/1610, Tower 1,
Kerry Everbright City
No. 218 Tianmu Road West,
Shanghai, P.R.C. 200070
Phone: +86-21-6354-6323
Fax: +86-21-6354-6325
e-mail:
chinasales@powerint.com

INDIA

#1, 14th Main Road
Vasanthanagar
Bangalore-560052 India
Phone: +91-80-41138020
Fax: +91-80-41138023
e-mail: indiasales@powerint.com

KOREA

RM 602, 6FL
Korea City Air Terminal B/D,
159-6
Samsung-Dong, Kangnam-
Gu,
Seoul, 135-728, Korea
Phone: +82-2-2016-6610
Fax: +82-2-2016-6630
e-mail:
koreasales@powerint.com

UNITED KINGDOM

1st Floor, St. James's House
East Street, Farnham
Surrey, GU9 7TJ
United Kingdom
Phone: +44 (0) 1252-730-141
Fax: +44 (0) 1252-727-689
e-mail:
eurosales@powerint.com

CHINA (SHENZHEN)

Rm A, B & C 4th Floor, Block C,
Electronics Science and
Technology Building, 2070
Shennan Zhong Rd,
Shenzhen, Guangdong,
China, 518031
Phone: +86-755-8379-3243
Fax: +86-755-8379-5828
e-mail:
chinasales@powerint.com

ITALY

Via De Amicis 2
20091 Bresso MI – Italy
Phone: +39-028-928-6000
Fax: +39-028-928-6009
e-mail: eurosales@powerint.com

SINGAPORE

51 Newton Road,
#15-08/10 Goldhill Plaza,
Singapore, 308900
Phone: +65-6358-2160
Fax: +65-6358-2015
e-mail:
singaporesales@powerint.com

APPLICATIONS HOTLINE

World Wide +1-408-414-9660

APPLICATIONS FAX

World Wide +1-408-414-9760

