



Design Example Report

Title	<i>1.5W Charger using LNK500P</i>
Specification	Input : 189 – 264 VAC Output : 7.5V / 200mA
Application	Cordless Phone Charger
Author	Power Integrations Applications Department
Document Number	DER-16
Date	February 4, 2004
Revision	1.0

Summary and Features

- Low Cost
- Low Parts Count
- No Optocoupler
- No Y-capacitor
- Meets EMI
- No load power consumption < 300 mW @ 230 Vac

The products and applications illustrated herein (including circuits external to the products and transformer construction) may be covered by one or more U.S. and foreign patents or potentially by pending U.S. and foreign patent applications assigned to Power Integrations. A complete list of Power Integrations' patents may be found at www.powerint.com

Table Of Contents

1	Introduction.....	3
2	Schematic.....	4
3	Power Supply Specifications.....	5
4	Power Supply Performance.....	6
4.1	Output Characteristic,	6
4.1.1	V-I curve without Z-R pre-load.....	6
4.1.2	At Light Load, with and without Z-R pre-load.....	7
4.2	Efficiency	7
4.2.1	Efficiency vs. Input voltage	7
4.2.2	Efficiency vs. output power	8
4.2.3	Efficiency vs. output power at light load.....	8
4.2.4	No load power consumption	9
4.3	Output Ripple.....	10
5	Conducted EMI Measurement.....	11
6	Transformer Design.....	12
6.1	Transformer Winding	12
6.2	Electrical Specifications	12
6.3	Transformer Construction	13
6.4	Winding Instructions.....	14
6.5	Materials	15
6.6	Design Notes:	15
7	Bill Of Material.....	15
8	Revision History	16

Important Notes:

Although this board is designed to satisfy safety isolation requirements, the engineering prototype has not been agency approved. Therefore, all testing should be performed using an isolation transformer to provide the AC input to the prototype board.

Design Reports contain a power supply design specification, schematic, bill of materials, and transformer documentation. Performance data and typical operation characteristics are included. Typically only a single prototype has been built.



1 Introduction.

This design example report shows the design of a 7.5V 200 mA cordless phone battery charger. The design is implemented using a LNK500 controller and an EE13 transformer.

Figure 1 shows VR1 and R3 as optional components, acting as a “Z-R pre-load”. They reduce the output no-load voltage from 10.6V to 9.6V. These components do not affect any other performance aspect of the power supply.

This report shows the power supply specifications, performance, transformer design, and bill of materials.



2 Schematic

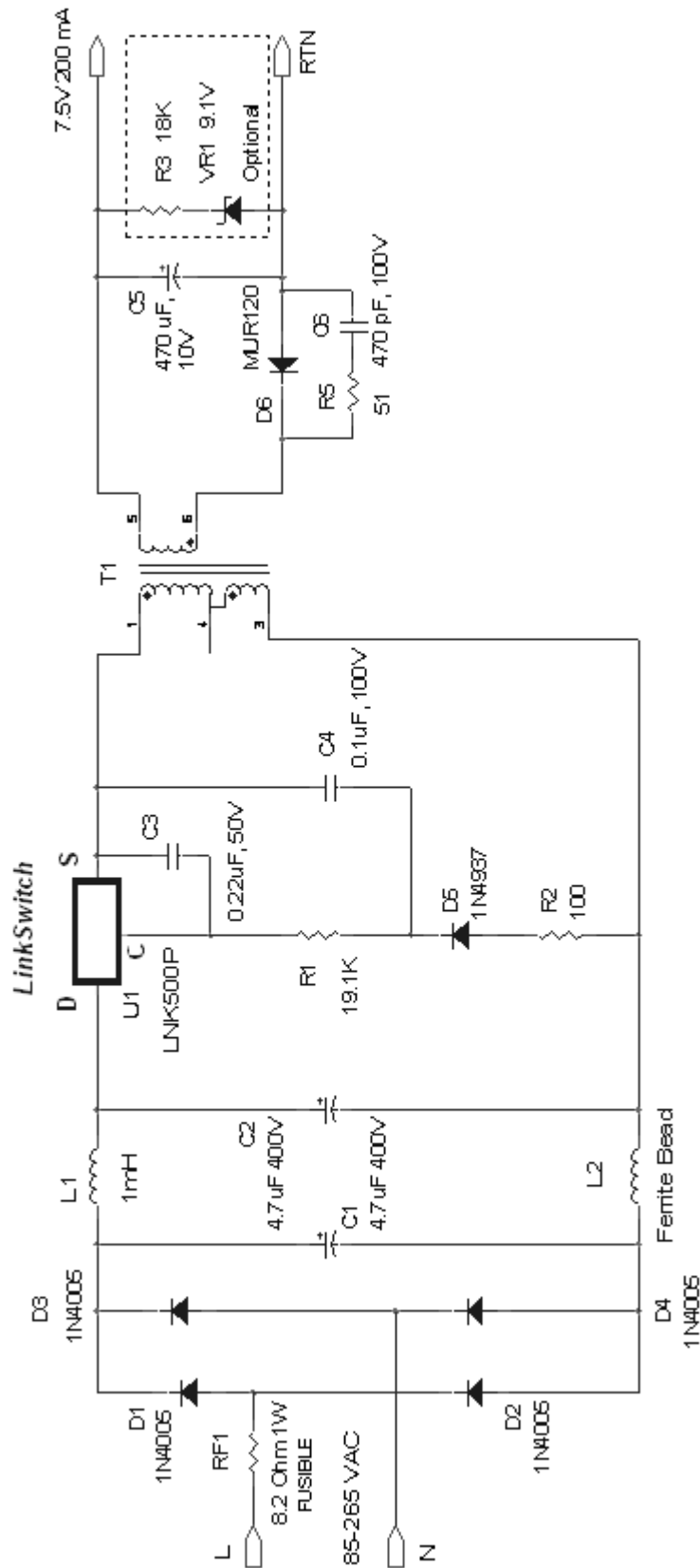

Figure 1 – Schematic. Components inside dashed box, the Z-R pre-load, are optional.



3 Power Supply Specifications.

The following table show the supply specifications.

	description		Comments
Input specification	Nominal input voltage	230V	
	Input voltage range	189VACto 264VAC	
	Nominal frequency	50Hz	
	Input frequency range	48Hz to 60Hz	
	No load power consumption @230V	< 300mW	
Output specification	Nominal output voltage	7,5V 200mA @230V	
See Power Output diagram	Nominal No load output voltage	8,5V @230V	
	Max output voltage	<10V @264V	
	Ripple max	300mV @189V	
	Output capacitor	470µF+/-20%10V	
Power supply protection	Short circuit protection	yes	
Environmental condition	Temperature range	Operating : -5 to +55° Storage : -40° to +70°	
	Relative humidity :	Operating : 10% to 80%° Storage : 10%° to 95%°	
Safety-specification	standard	IEC60950-1	untested
	Dielectric voltage	>3kVAC rms for 1min	untested
EMC specification	Noise suppressed	EN55022/B	> 10 dB margin
	Immunity to radiated electromagnetic field	EN 61000-4-3 80 to 1000MHz ; 80%AM 1kHz 3V/m & 1,4 to 2GHz	untested
	Immunity to fast electric transients	EN 61000-4-4 AC input 2kV	untested
	Surge Voltage	EN 61000-4-5 Common mode 1KV Differential mode 0,5KV	untested
	Immunity to conducted disturbances	EN 61000-4-6 0,15 to 80Mhz ; 80%AM 1khz 3Vrms	untested
ESD	Standard level	EN 61000-4 -2 Contact : +/-8kV Air/indirect : +/- 15kV	untested



4 Power Supply Performance.

The Z-R pre-load has no effect on the power supply performance except the output V-I characteristic (4.1 and 4.2).

Note: All measurements were made at the end of the output cable. Output cable resistance is 0.2 Ω.

4.1 Output Characteristic,

4.1.1 V-I curve without Z-R pre-load

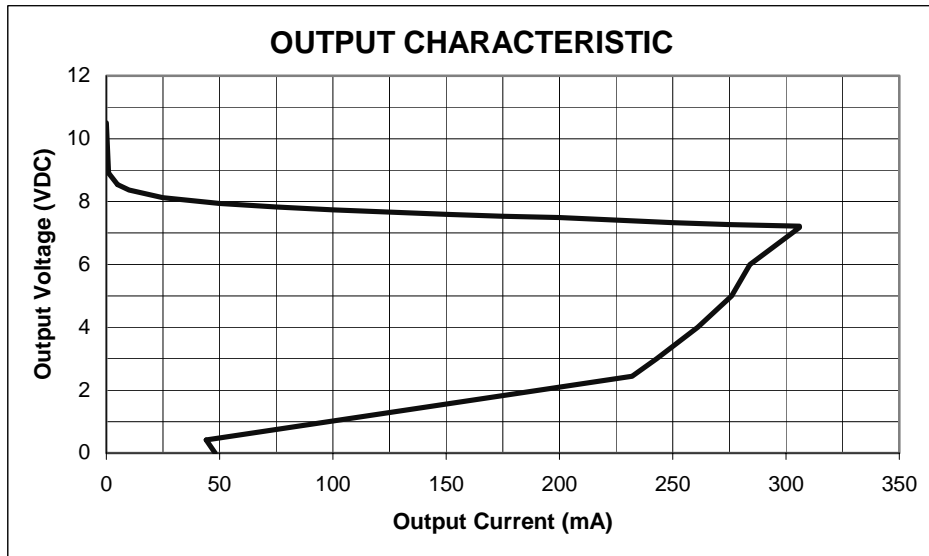

Figure 2 Typical Output Characteristic, without Z-R preload circuit, at 230 Vac



4.1.2 At Light Load, with and without Z-R pre-load

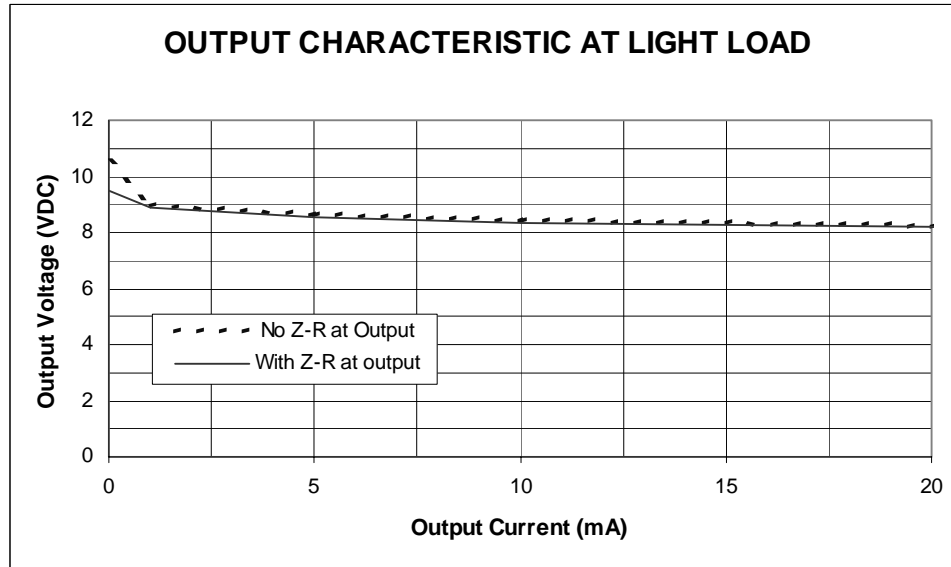

Figure 3 Output Characteristic at light load with and without Zener-Resistor pre-load.

4.2 Efficiency

4.2.1 Efficiency vs. Input voltage

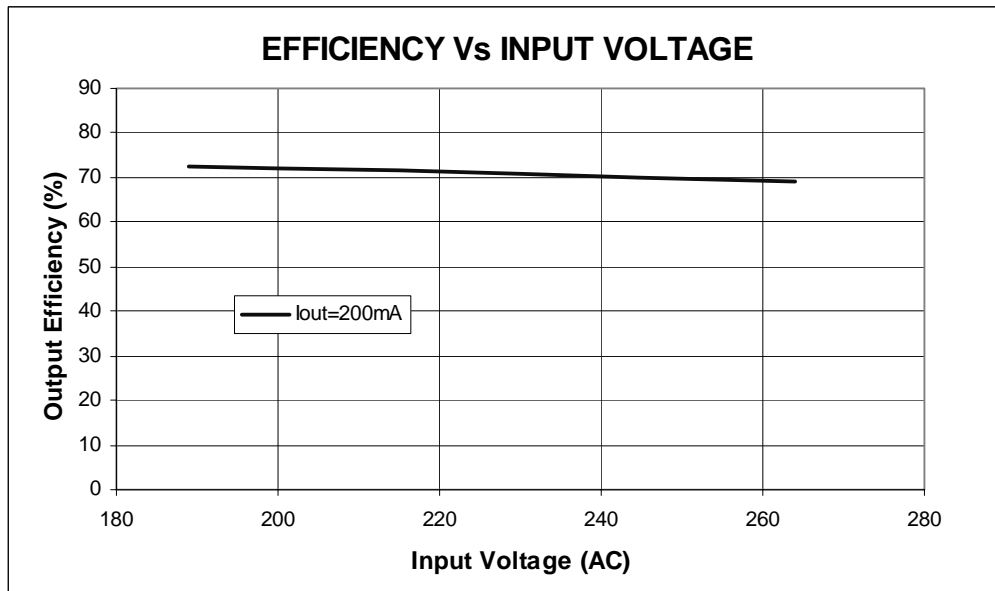

Figure 4 Efficiency vs. Input Voltage



4.2.2 Efficiency vs. output power

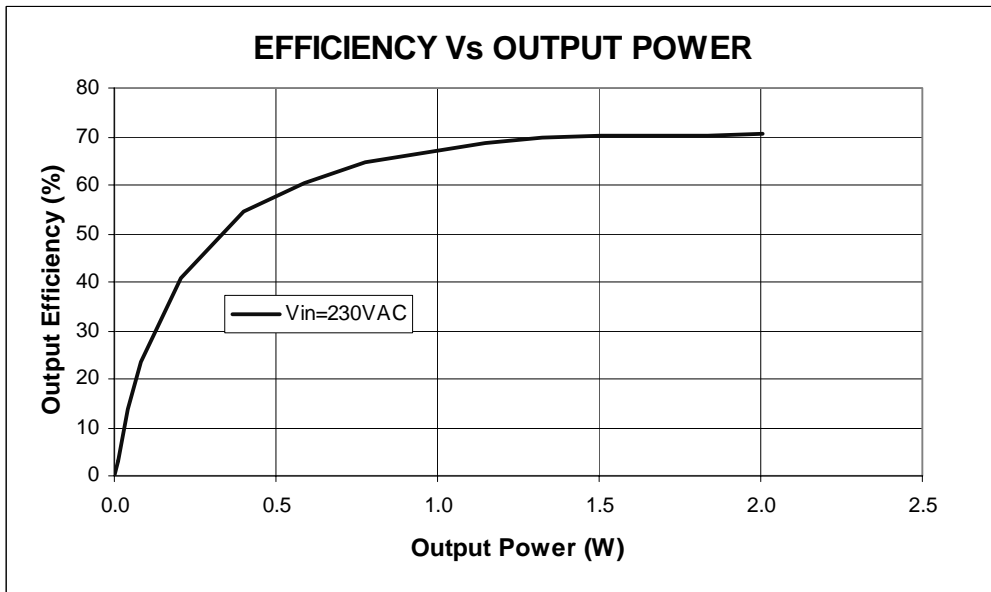

Figure 5 Efficiency vs. Output Power, at 230 Vac

4.2.3 Efficiency vs. output power at light load

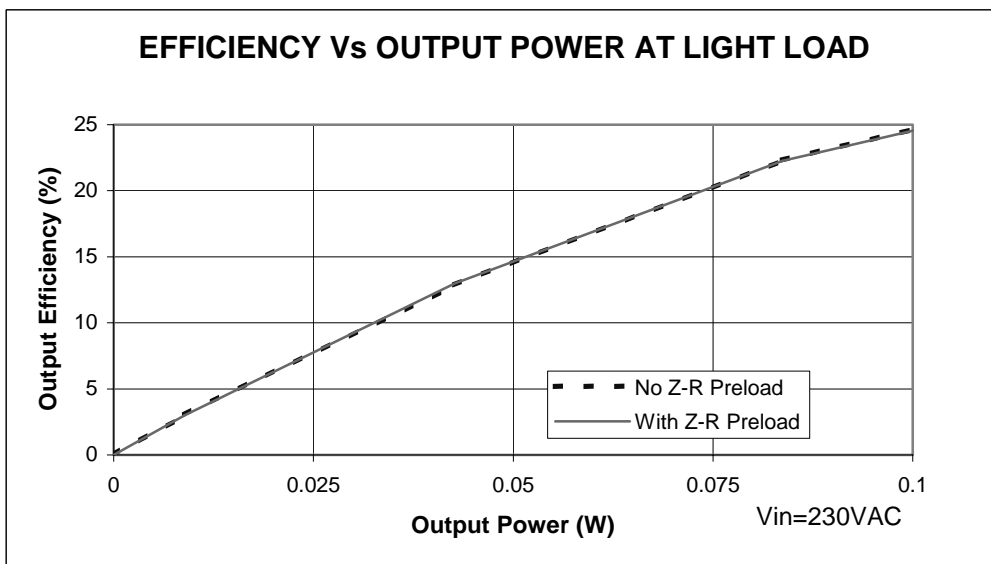

Figure 6 Efficiency vs. Output Power at Light Load, at 230 Vac



4.2.4 No load power consumption

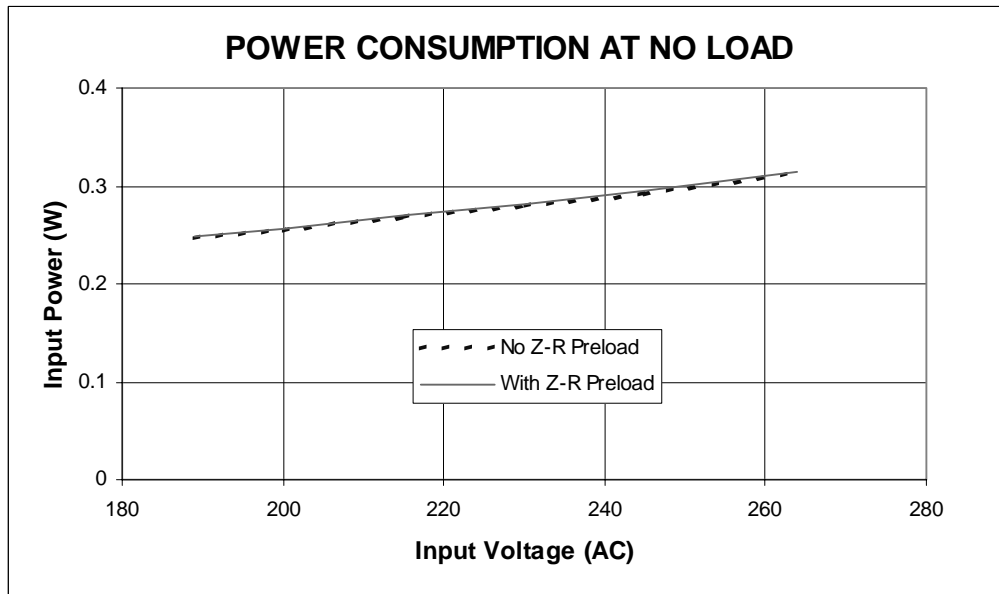

Figure 7 No Load Power Consumption



4.3 Output Ripple.

13-Mar-03
15:10:45

3
2 ms
200 mV

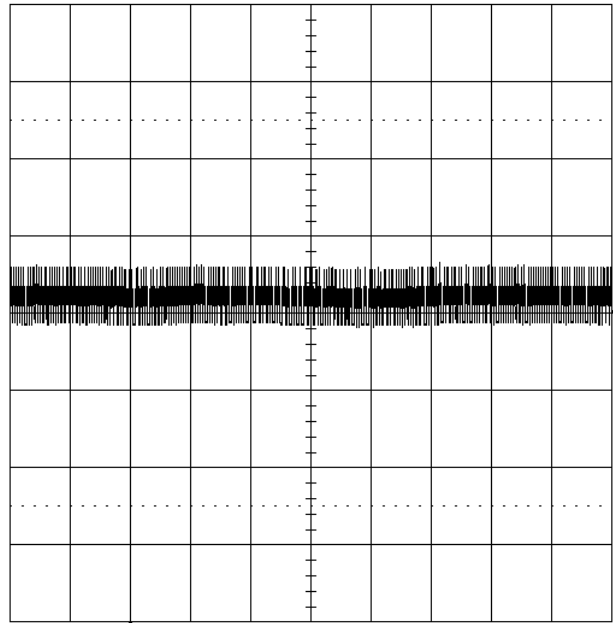

2 ms BWL

- 1 10 mV 50Ω
- 2 .2 V DC
- 3 20 mV AC $\times \frac{1}{10}$
- 4 2 V DC $\times \frac{1}{100}$



1 DC 29.0 mV

2.5 MS/s

□ SINGLE

Figure 8 Output Ripple. V_{in} 189VAC. V_{out} 7.3V at 200mA Resistive Load.



5 Conducted EMI Measurement.

Figure below shows the conducted EMI measured under worst case conditions. Output common is connected to "Artificial Hand" plug of the LISN.

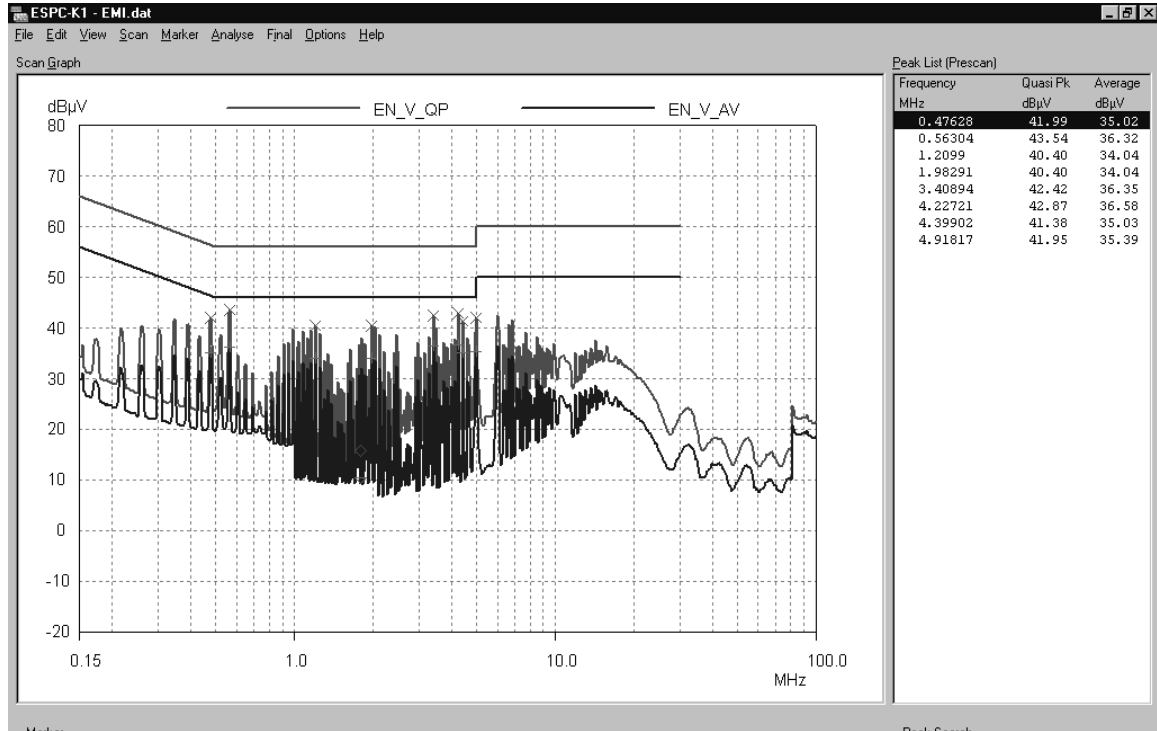

Figure 9 - Measured Conducted EMI. Input 230V; Output 7.3V at 200mA; Detection Mode: Quasi-Peak and Average; Phase: Line.

6 Transformer Design

6.1 Transformer Winding

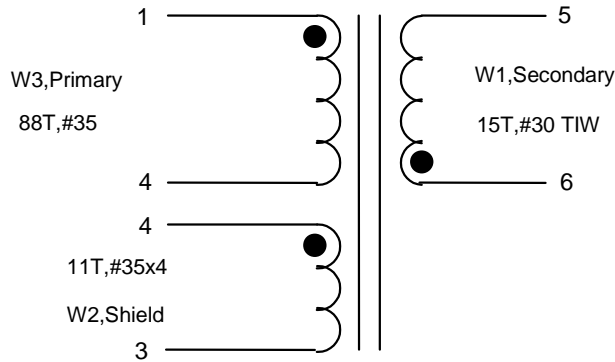

Figure 10 – Transformer Winding

6.2 Electrical Specifications

Electrical Strength	60Hz 1minute, from Pins 1-4 to Pins 5-6	3 kV for 1 minute
Primary Inductance (Pin 1 to Pin 3)	All windings open	1.73 mH \pm 7 % @42KHz
Resonant Frequency	All windings open	300 kHz min.
Primary Leakage Inductance	L_{13} with pins 5-6 shorted	35 μ H max.



6.3 Transformer Construction

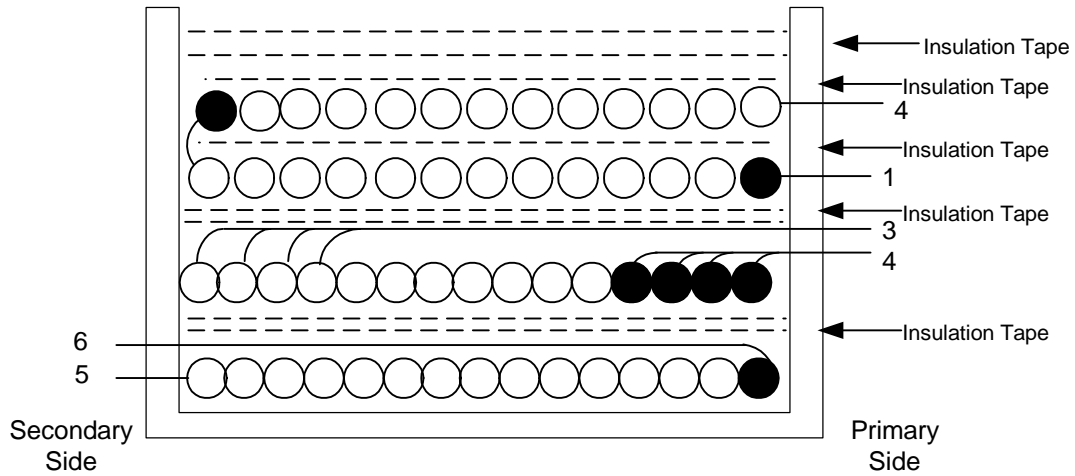

Figure 11 – Transformer construction (does not show flux band)

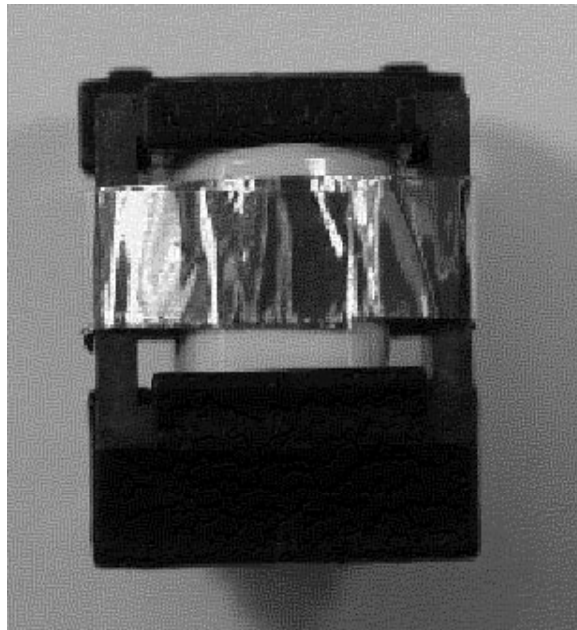

Figure 12 – Flux Band position (does not show connection to pin 3)





Figure 13 - Tape Insulator over flux band (after connecting flux band to pin 3)

6.4 Winding Instructions

Bobbin orientation	Place the bobbin on the winding machine with pins 1-4 oriented to the right side.
W1 (Secondary Winding)	Wind 15 turns with # 30 triple insulated wire from right to left starting temporarily from 1 and finishing at 5. Move the starting end from pin 1 to pin 6.
Basic Insulation	2 layers of tape for insulation.
W2 (Shield)	Wind 11 turns with #35 x 4 (quad-filar) magnet wire from right to left starting from 4 and finishing at 3. Wind evenly across the width of the bobbin without any gaps at the sides.
Basic Insulation	2 layers of tape for insulation.
W3 (Primary Winding)	Wind 88 turns in 2 layers with # 35 AWG magnet wire – first layer 44T from right to left starting from pin 1 – then wind one layer of insulation tape – then second layer 44T from left to right, finishing at pin 4.
Basic Insulation	3 layers of tape for insulation.
Core Assembly	Assemble and secure core halves with tape.
Flux Band	Affix flux band around assembled core and bobbin, solder the ends together. Connect the flux band to pin 3 with a piece of #35 AWG magnet wire.
Outer Insulation	2 layers of tape for insulation.
Final Assembly	Solder the transformer pins and impregnate transformer uniformly with varnish.



6.5 Materials

Item	Description
[1]	Core: EE13, PC40EE13, TDK Gapped for AL = $176.5 \text{ nH/T}^2 \pm 7 \%$
[2]	Bobbin: Horizontal 8 pins
[3]	Magnet Wire: #35 AWG
[4]	Triple Insulated wire: # 30 AWG
[5]	Copper foil, 0.2 inch x 2 mils
[6]	Tape: 3M 1298 Polyester Film (white) 0.29" x 2 mils
[7]	Varnish

6.6 Design Notes:

Power Integrations Device	LNK500P
Frequency of Operation	42 KHz
Mode	discontinuous
Peak Current	0.25 A
Reflected Output Voltage (Secondary to Primary)	57 V
Maximum AC Input Voltage	264 V
Minimum AC Input Voltage	189 V

7 Bill of Material.

Item	Quantity	Reference	Part Description.
1	2	C1,C2	4.7uF 400V, Electrolytic
2	1	C3	0.22uF, 50V, Ceramic
3	1	C4	0.1uF, 100V, Metal Film
4	1	C5	470uF 10V, Low ESR
5	1	C6	470 pF, 100V, Ceramic
6	4	D1,D2,D3,D4	1N4005, 1Amp, 600V
7	1	D5	1N4937, 1A, 600V, Fast Rectifier.
8	1	D6	MUR120, 1Amp, 200V, UFR
9	1	L1	1mH, Inductor
10	1	L2	Ferrite Bead
11	1	RF1	8.2 Ohm 1W, Fusible Resistor
12	1	R1	19.1K, 1/4W, 1%
13	1	R2	100, 1/8W, 5%
14	1	R5	51, 1/8W, 5%.
15	1	T1	Custom Transformer
16	1	U1	LNK500P
17	1	R3	18K, 1/8W, 5% (Optional)
18	1	VR1	Zener, 9.1V 500mW (Optional)



8 Revision History

Date	Author	Revision	Description & changes	Reviewed
February 4, 2004	VC/JC	1.0	Initial release	AM/VC



Notes



For the latest updates, visit our Web site: www.powerint.com

Power Integrations reserves the right to make changes to its products at any time to improve reliability or manufacturability. Power Integrations does not assume any liability arising from the use of any device or circuit described herein, nor does it convey any license under its patent rights or the rights of others.

The products and applications illustrated herein (including circuits external to the products and transformer construction) may be covered by one or more U.S. and foreign patents or potentially by pending U.S. and foreign patent applications assigned to Power Integrations. A complete list of Power Integrations' patents may be found at www.powerint.com.

The PI Logo, **TOPSwitch**, **TinySwitch**, **LinkSwitch**, and **EcoSmart** are registered trademarks of Power Integrations, Inc. **PI Expert** and **DPA-Switch** are trademarks of Power Integrations, Inc.
© Copyright 2003, Power Integrations, Inc.

WORLD HEADQUARTERS

AMERICAS

Power Integrations
5245 Hellyer Avenue
San Jose, CA 95138 USA.
Main: +1-408-414-9200
Customer Service:
Phone: +1-408-414-9665
Fax: +1-408-414-9765
E-Mail:
usasales@powerint.com

CHINA

Power Integrations
International Holdings, Inc.
Rm# 1705, Bao Hua Bldg.
1016 Hua Qiang Bei Lu
Shenzhen Guangdong,
518031, China
Phone: +86-755-8367-5143
Fax: +86-755-8377-9610
E-Mail:
chinasales@powerint.com
APPLICATIONS HOTLINE
World Wide +1-408-414-9660

EUROPE & AFRICA

Power Integrations (Europe) Ltd.
Centennial Court
Easthampstead Road
Bracknell
Berkshire RG12 1YQ,
United Kingdom
Phone: +44-1344-462-300
Fax: +44-1344-311-732
E-Mail:
eurosales@powerint.com

m

KOREA

Power Integrations
International Holdings, Inc.
Rm# 402, Handuk Building,
649-4 Yeoksam-Dong, Kangnam-Gu
Seoul, Korea
Phone: +82-2-568-7520
Fax: +82-2-568-7474
E-Mail:
koreasales@powerint.com
om
APPLICATIONS FAX
World Wide +1-408-414-9760

SINGAPORE

Power Integrations, Singapore
51 Goldhill Plaza #16-05
Republic of Singapore 308900
Phone: +65-6358-2160
Fax: +65-6358-2015
E-Mail:
singaporesales@powerint.com

JAPAN

Power Integrations, K.K.
Keihin-Tatemono 1st Bldg.
12-20 Shin-Yokohama
2-Chome,
Kohoku-ku, Yokohama-shi,
Kanagawa 222-0033, Japan
Phone: +81-45-471-1021
Fax: +81-45-471-3717
E-Mail:
Japansales@powerint.com

TAIWAN

Power Integrations
International Holdings, Inc.
17F-3, No. 510,
Chung Hsiao E. Rd., Sec. 5,
Taipei, Taiwan 110, R.O.C.
Phone: +886-2-2727-1221
Fax: +886-2-2727-1223
E-Mail:
taiwansales@powerint.com

INDIA (Technical Support)

Innovatech
#1, 8th Main Road
Vasanthnagar
Bangalore, India 560052
Phone: +91-80-226-6023
Fax: +91-80-228-9727
E-Mail:
indiasales@powerint.com

