

Application Note AN-37

LinkSwitch-TN Family



Design Guide

Introduction

LinkSwitch-TN combines a high voltage power MOSFET switch with an ON/OFF controller in one device. It is completely self-powered from the DRAIN pin, has a jittered switching frequency for low EMI and is fully fault protected. Auto-restart limits device and circuit dissipation during overload and output short circuit (LNK304-306) while over temperature protection disables the internal MOSFET during thermal faults. The high thermal shutdown threshold is ideal for applications where the ambient temperature is high while the large hysteresis protects the PCB and surrounding components from high average temperatures.

LinkSwitch-TN is designed for any application where a non-isolated supply is required such as appliances (coffee machines, rice cookers, dishwashers, microwave ovens etc.), nightlights, emergency exit signs and LED drivers. LinkSwitch-TN can be configured in all common topologies to give a line or neutral referenced output and an inverted or non-inverted output voltage – ideal for applications using triacs for AC load control. Using a switching power supply rather than a passive dropper (capacitive or resistive) gives a number of advantages, some of which are listed below.

- Universal input – the same power supply/product can be used worldwide
- High power density – smaller size, no μF 's of X class capacitance needed

- High efficiency – full load efficiencies >75% typical for 12 V output
- Excellent line and load regulation
- High efficiency at light load – ON/OFF control maintains high efficiency even at light load
- Extremely energy efficient – input power <100 mW at no load
- Entirely manufacturable in SMD
- More robust to drop test mechanical shock
- Fully fault protected (overload, short circuit and thermal faults)
- Scalable – LinkSwitch-TN family allows the same basic design to be used from <50 mA to 360 mA

Scope

This application note is for engineers designing a non-isolated power supply using the LinkSwitch-TN family of devices. This document describes the design procedure for buck and buck-boost converters using the LinkSwitch-TN family of integrated off-line switchers. The objective of this document is to provide power supply engineers with guidelines in order to enable them to quickly build efficient and low cost buck or buck-boost converter based power supplies using low cost off-the-shelf inductors. Complete design equations are provided for the selection of the converter's key components. Since the power MOSFET and controller are integrated into a single IC the design process is greatly simplified, the circuit configuration has few parts and no transformer is required. Therefore a quick start section is provided that allows off-the-shelf components to be selected for common output voltages and currents.

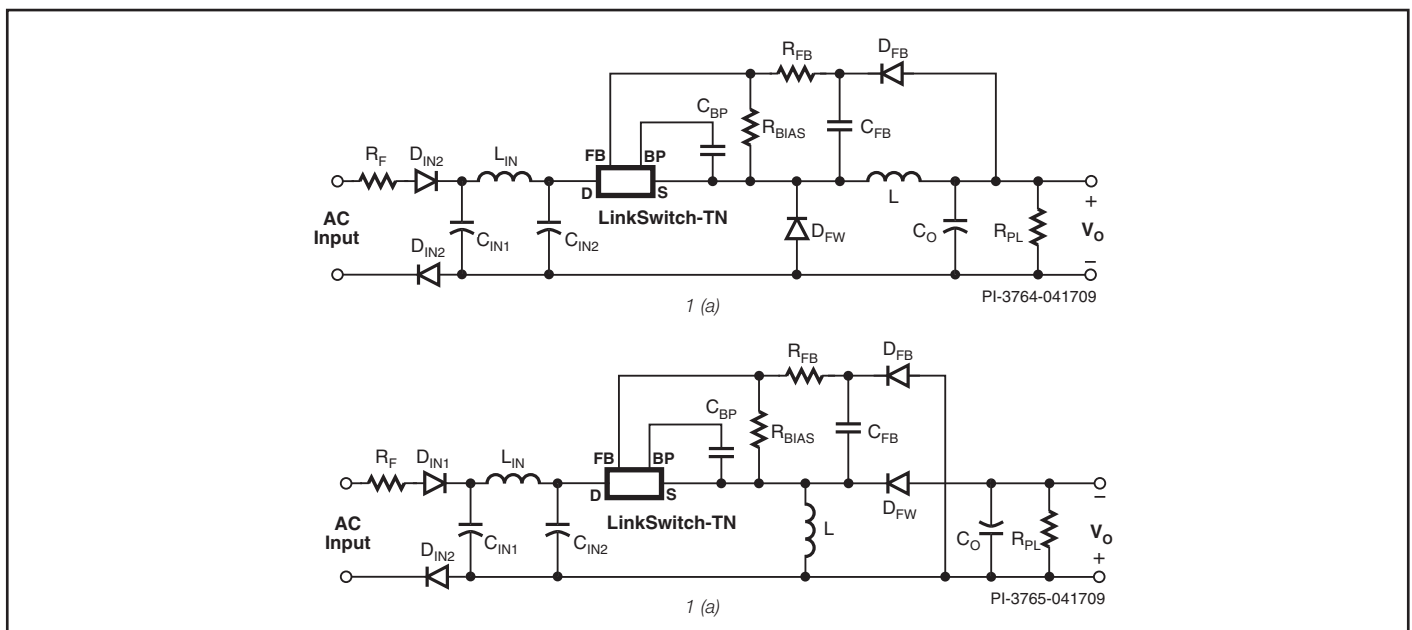

Figure 1 (a). Basic Configuration using LinkSwitch-TN in a Buck Converter. Figure 1 (b) Basic Configuration using LinkSwitch-TN in a Buck-Boost Converter.

In addition to this application note a design spreadsheet is available within the PIXIs tool in the PI Expert design software suite. The reader may also find the LinkSwitch-TN DAK engineering prototype board useful as an example of a working supply. Further details of support tools and updates to this document can be found at www.powerint.com.

Quick Start

Readers wanting to start immediately can use the following information to quickly select the components for a new design, using Figure 1 and Tables 1 and 2 as references.

1. For AC input designs select the input stage (Table 9).

2. Select the topology (Tables 1 and 2).
 - If better than $\pm 10\%$ output regulation is required, then use optocoupler feedback with suitable reference.
3. Select the LinkSwitch-TN device, L , R_{FB} or V_Z , R_{BIAS} , C_{FB} , R_Z and the reverse recovery time for D_{FW} (Table 4: Buck, Table 5: Buck-Boost).
4. Select freewheeling diode to meet t_{rr} determined in Step 3 (Table 3).
5. For direct feedback designs, if the minimum load < 3 mA then calculate $R_{PL} = V_O / 3$ mA.
6. Select C_O as $100 \mu\text{F}$, $1.25 \times V_O$, low ESR type.
7. Construct prototype and verify design.

Topology	Basic Circuit Schematic	Key Features
High-Side Buck – Direct Feedback		<ol style="list-style-type: none"> 1. Output referenced to input 2. Positive output (V_O) with respect to $-V_{IN}$ 3. Step down – $V_O < V_{IN}$ 4. Low cost direct feedback ($\pm 10\%$ typ.) 5. Requires an output load to maintain regulation (Note2)
High-Side Buck-Boost – Direct Feedback		<ol style="list-style-type: none"> 1. Output referenced to input 2. Negative output (V_O) with respect to $-V_{IN}$ 3. Step down – $V_O > V_{IN}$ or $V_O < V_{IN}$ 4. Low cost direct feedback ($\pm 10\%$ typ.) 5. Fail-safe – output is not subjected to input voltage if the internal MOSFET fails 6. Ideal for driving LEDs – better accuracy and temperature stability than low-side buck constant current LED driver 7. Requires an output load to maintain regulation (Note 2)

Notes:

1. Low Cost, directly sensed feedback typically achieves overall regulation tolerance of $\pm 10\%$.
2. To ensure output regulation, a pre-load may be required to maintain a minimum load current of 3 mA (buck and buck-boost only).
3. Boost topology (step up) also possible but not shown.

Table 1. LinkSwitch-TN Circuit Configurations Using Directly Sensed Feedback.

V _{OUT}	I _{OUT(MAX)}	Inductor			LNK30X	Mode	Diode t _{rr}	R _{FB} *	V _Z	
		μH I _{RMS} (mA)	Token	Coilcraft						
5	≤65	1200	70	-	RFB0807-122	LNK302	MDCM CCM	≤75 ns	3.84 kΩ	3.9 V
	80	1200	80	-	RFB0807-122	LNK304	MDCM CCM	≤75 ns		
	120	680	220	SBC2-681-211	RFB0807-681		MDCM CCM	≤75 ns		
	160	680	230	SBC2-681-211	RFB0807-681	LNK305	MDCM CCM	≤75 ns		
	175	680	320	SBC3-681-211	RFB0810-681		MDCM CCM	≤75 ns		
	225	680	340	SBC4-681-211	RFB0810-681	LNK306	MDCM CCM	≤75 ns		
	280	680	440	SBC4-681-211	RFB0810-681		MDCM CCM	≤75 ns		
12	≤60	1800	70	-	RFB0807-222	LNK302	MDCM CCM	≤75 ns	11.86 kΩ	11 V
	80	2700	80	-	RFB0807-272	LNK304	MDCM MDCM CCM	≤75 ns		
	85	680	180	SBC2-681-211	RFB0807-681		MDCM CCM	≤75 ns		
	120	1000	230	SBC3-102-281	RFB0807-102	LNK305	MDCM CCM	≤75 ns		
	160	1500	320	SBC3-152-251	RFB0810-152		MDCM CCM	≤75 ns		
	175	680	340	SBC3-681-361	RFB0810-681	LNK306	MDCM CCM	≤75 ns		
	225	1000	440	SBC4-102-291	RFB0810-102		MDCM CCM	≤75 ns		
	280	680	430	SBC4-681-431	RFB0810-681	MDCM CCM	≤35 ns			
15	≤65	2200	70	SBC3-222-191	RFB0807-222	LNK302	MDCM CCM	≤75 ns	15.29 kΩ	13 V
	80	3300	80	SBC3-332-151	RFB0807-332	LNK304	MDCM MDCM CCM	≤75 ns		
	70	680	160	SBC2-681-211	RFB0807-681		MDCM CCM	≤75 ns		
	120	1200	210	-	RFB0807-122	LNK305	MDCM CCM	≤75 ns		
	160	1800	210	-	RFB0810-182		MDCM CCM	≤75 ns		
	175	820	310	-	RFB0810-821	LNK306	MDCM CCM	≤75 ns		
	225	1200	310	-	RFB1010-122		MDCM CCM	≤75 ns		
	280	820	390	SBC6-152-451	RFB1010-821	MDCM CCM	≤35 ns			
24	≤65	3300	70	SBC3-332-151	RFB0807-332	LNK302	MDCM CCM	≤75 ns	25.6 kΩ	22 V
	80	4700	80	SBC3-472-181	RFB0807-472	LNK304	MDCM MDCM CCM	≤75 ns		
	50	680	130	SBC2-681-211	RFB0807-681		MDCM CCM	≤75 ns		
	120	1500	190	SBC4-152-221	RFB0810-152	LNK305	MDCM CCM	≤75 ns		
	160	2200	180	SBC4-222-211	RFB0810-222		MDCM CCM	≤75 ns		
	175	1200	280	-	RFB0810-122	LNK306	MDCM CCM	≤75 ns		
	225	1500	280	SBC6-152-451	RFB1010-152		MDCM CCM	≤75 ns		
	280	1200	350	-	RFB1010-122	MDCM CCM	≤35 ns			

Other Standard Components

- R_{BIAS}: 2 kΩ, 1%, 1/8 W
- C_{BP}: 0.1 μF, 50 V Ceramic
- C_{FB}: 10 μF, 1.25 · V_O
- D_{FB}: 1N4005GP
- R_Z: 470 Ω to 2 kΩ, 1/8 W, 5%

Table 4. Components Quick Select for Buck Converters. *Select nearest standard or combination of standard values.

V _{OUT}	I _{OUT(MAX)}	Inductor				LNK30X	Mode	Diode t _{rr}	R _{FB} [*]	V _Z
		μH I _{RMS} (mA)		Tokin	Coilcraft					
5	≤65	1200	70	-	-	LNK302	MDCM CCM	≤75 ns	3.84 kΩ	3.9 V
	80	1500	80	SBC3-152-251	RFB0807-122	LNK304	MDCM CCM	≤75 ns		
	120	680	220	SBC2-681-211	RFB0807-152		MDCM CCM	≤75 ns		
	160	680	230	SBC2-681-211	RFB0807-681	LNK305	MDCM CCM	≤75 ns		
	175	680	340	SBC3-681-361	RFB0807-681		MDCM CCM	≤75 ns		
	225	680	320	SBC4-681-431	RFB0810-681	LNK306	MDCM CCM	≤75 ns		
	280	680	440	SBC4-681-431	RFB0810-681		MDCM CCM	≤75 ns		
12	≤60	2200	70	SBC3-222-191	RFB0807-222	LNK302	MDCM CCM	≤75 ns	11.86 kΩ	11 V
	80	3300	90	SBC3-332-151	RFB0807-332	LNK304	MDCM CCM	≤75 ns		
	85	680	180	SBC2-681-211	RFB0807-681		MDCM CCM	≤75 ns		
	120	1200	220	-	RFB1010-122	LNK305	MDCM CCM	≤75 ns		
	160	1800	210	-	RFB0807-182		MDCM CCM	≤75 ns		
	175	820	320	-	RFB0807-821	LNK306	MDCM CCM	≤75 ns		
	225	1200	310	-	RFB0810-122		MDCM CCM	≤75 ns		
	280	820	410	-	RFB0810-821	MDCM CCM	≤35 ns			
15	≤65	2200	70	SBC3-222-191	RFB0807-222	LNK302	MDCM CCM	≤75 ns	15.29 kΩ	13 V
	80	3900	90	-	RFB0807-392	LNK304	MDCM CCM	≤75 ns		
	70	680	180	SBC2-681-211	RFB0807-681		MDCM CCM	≤75 ns		
	120	1500	220	SBC3-152-251	RFB0807-152	LNK305	MDCM CCM	≤75 ns		
	160	2200	220	SBC4-222-211	RFB0810-222		MDCM CCM	≤75 ns		
	175	1000	320	SBC4-102-291	RFB0810-102	LNK306	MDCM CCM	≤75 ns		
	225	1500	320	SBC4-152-251	RFB0810-152		MDCM CCM	≤75 ns		
280	1200	400	-	RFB0810-122	MDCM CCM	≤35 ns				
24	≤65	3300	70	SBC3-332-151	RFB0807-332	LNK302	MDCM CCM	≤75 ns	25.6 kΩ	22 V
	80	6800	100	SBC3-682-111	RFB0807-682	LNK304	MDCM CCM	≤75 ns		
	50	680	180	SBC2-681-211	RFB0807-681		MDCM CCM	≤75 ns		
	120	2200	210	SBC3-222-191	RFB0810-222	LNK305	MDCM CCM	≤75 ns		
	160	3300	210	SBC4-332-161	RFB0810-332		MDCM CCM	≤75 ns		
	175	1800	300	-	RFB0810-182	LNK306	MDCM CCM	≤75 ns		
	225	2200	290	SBC4-222-211	RFB1010-222		MDCM CCM	≤75 ns		
	280	1800	370	-	RFB1010-182	MDCM CCM	≤35 ns			

Other Standard Components

R_{BIAS}: 2 kΩ, 1%, 1/8 WC_{BP}: 0.1 μF, 50 V CeramicC_{FB}: 10 μF, 1.25 • V_oD_{FB}: 1N4005GPR_Z: 470 Ω to 2 kΩ, 1/8 W, 5%

Table 5. Components Quick Select for Buck-Boost Converters. *Select nearest standard or combination of standard values.

LinkSwitch-TN Circuit Design

LinkSwitch-TN Operation

The basic circuit configuration for a buck converter using LinkSwitch-TN is shown in Figure 1(a).

To regulate the output, an ON/OFF control scheme is used as illustrated in Table 6. As the decision to switch is made on a cycle-by-cycle basis, the resultant power supply has extremely good transient response and removes the need for control loop compensation components. If no feedback is received for 50 ms, then the supply enters auto-restart (LNK304-306 only).

<p>Reference Schematic And Key</p>	<p style="text-align: right;">PI-3784-041709</p>	
<p>Normal Operation</p>	<p style="text-align: right;">PI-3767-121903</p>	<p>At the beginning of each cycle, the FEEDBACK (FB) pin is sampled.</p> <ul style="list-style-type: none"> • If $I_{FB} < 49 \mu A$ then next cycle occurs • If $I_{FB} > 49 \mu A$ then next switching cycle is skipped <p>High load – few cycles skipped</p> <p>Low load – many cycles skipped</p>
<p>Auto-Restart (LNK304-306 only)</p>	<p style="text-align: center;">$I_{FB} < 49 \mu A, > 50 \text{ ms}$ = Auto-Restart</p> <p style="text-align: center;">Auto-Restart = 50 ms ON / 800 ms OFF</p> <p style="text-align: right;">PI-3768-083004</p>	<p>If no feedback ($I_{FB} < 49 \mu A$) for $> 50 \text{ ms}$, then output switching is disabled for approximately 800 ms.</p>

Table 6. LinkSwitch-TN Operation.

To allow direct sensing of the output voltage without the need for a reference (Zener diode or reference IC), the FB pin voltage is tightly toleranced over the entire operating temperature range. For example, this allows a 12 V design with an overall output tolerance of $\pm 10\%$. For higher performance, an optocoupler can be used with a reference as shown in Table 2. Since the optocoupler just provides level shifting, it does not need to be safety rated or approved. The use of an optocoupler also allows flexibility in the location of the device, for example it allows a buck converter configuration with the LinkSwitch-TN in the low-side return rail, reducing EMI as the SOURCE pins and connected components are no longer part of the switching node.

Selecting the Topology

If possible, use the buck topology. The buck topology maximizes the available output power from a given LinkSwitch-TN and inductor value. Also, the voltage stress on the power switch

and freewheeling diode and the average current through the output inductor are slightly lower in the buck topology as compared to the buck-boost topology.

Selecting the Operating Mode – MDCM and CCM Operation

At the start of a design, select between mostly discontinuous conduction mode (MDCM) and continuous conduction mode (CCM) as this decides the selection of the LinkSwitch-TN device, freewheeling diode and inductor. For maximum output current select CCM, for all other cases MDCM is recommended. Over-all, select the operating mode and components to give the lowest overall solution cost. Table 7 summarizes the trade-offs between the two operating modes.

Additional differences between CCM and MDCM include better transient response for DCM and lower output ripple (for same capacitor ESR) for CCM. However these differences, at the low

Comparison of CCM and MDCM Operating Modes

Operating Mode	MDCM	CCM
Operating Description	 <p style="text-align: right;">PI-3769-121803</p> <p>Inductor current falls to zero during t_{OFF}. borderline between MDCM and CCM when $t_{IDLE} = 0$.</p>	 <p style="text-align: right;">PI-3770-121503</p> <p>Current flows continuously in the inductor for the entire duration of a switching cycle.</p>
Inductor	Lower Cost Lower value, smaller size.	Higher Cost Higher value, larger size.
Freewheeling Diode	Lower Cost 75 ns ultra-fast reverse recovery type (≤ 35 ns for ambient >70 °C).	Higher Cost 35 ns ultra-fast recovery type required.
LinkSwitch-TN	Potentially Higher Cost May require larger device to deliver required output current—depends on required output current.	Potentially Lowest Cost May allow smaller device to deliver required output current—depends on required output current.
Efficiency	Higher Efficiency Lower switching losses.	Lower Efficiency Higher switching losses.
Overall		Typically Higher Cost

Table 7. Comparison of Mostly Discontinuous Conduction (MDCM) and Continuous Conduction (CCM) Modes of Operation.

output currents of LinkSwitch-TN applications, are normally not significant.

The conduction mode CCM or MDCM of a buck or buck-boost converter primarily depends on input voltage, output voltage, output current and device current limit. The input voltage, output voltage and output current are fixed design parameters, therefore the LinkSwitch-TN (current limit) is the only design parameter that sets the conduction mode.

The phrase “mostly discontinuous” is used as with on-off control, since a few switching cycles may exhibit continuous inductor current, the majority of the switching cycles will be in the discontinuous conduction mode. A design can be made fully discontinuous but that will limit the available output current, making the design less cost effective.

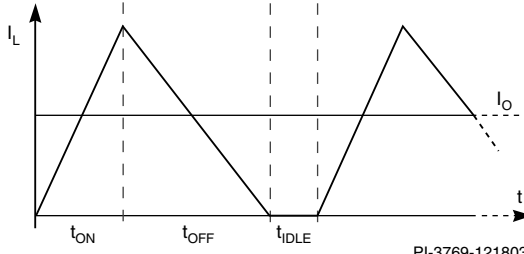
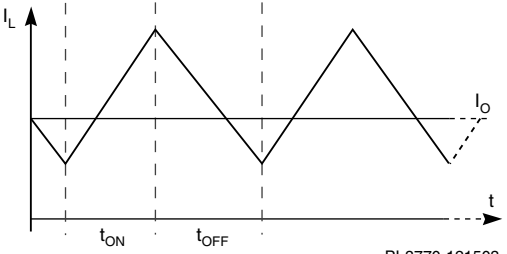
Step-by-Step Design Procedure

Step 1. Determine System Requirements V_{AC_MIN} , V_{AC_MAX} , P_o , V_o , f_L , η

Determine the input voltage range from Table 8.

Input (VAC)	V_{AC_MIN}	V_{AC_MAX}
100/115	85	132
230	195	265
Universal	85	265

Table 8. Standard Worldwide Input Line Voltage Ranges.

Line Frequency, f_L : 50 or 60 Hz, for half-wave rectification use $f_L/2$.

Output Voltage, V_o : in Volts.

Output Power, P_o : in Watts.

Power supply efficiency, η : 0.7 for a 12 V output, 0.55 for a 5 V output if no better reference data available.

AC Input Voltage (VAC)	Total Capacitance $C_{IN(TOTAL)}$ $\mu F/P_{OUT} (C_{IN1} + C_{IN2})$	
	Half Wave Rectification	Full Wave Rectification
100/115	6-8	3-4
230	1-2	1
Universal	6-8	3-4

Table 10. Suggested Total Input Capacitance Values for Different Input Voltage Ranges.

Step 2. Determine AC Input Stage

The input stage comprises fusible resistor(s), input rectification diodes and line filter network. The fusible resistor should be chosen as flameproof and, depending on the differential line input surge requirements, a wire-wound type may be required. The fusible resistor(s) provides fuse safety, inrush current limiting and differential mode noise attenuation.

For designs ≤ 1 W, it is lower cost to use half-wave rectification; >1 W, full wave rectification (smaller input capacitors). The EMI performance of half-wave rectified designs is improved by adding a second diode in the lower return rail. This provides EMI gating (EMI currents only flow when the diode is conducting) and also doubles differential surge withstand as the surge voltage is shared across two diodes. Table 9 shows the recommended input stage based on output power for a universal input design while Table 10 shows how to adjust the input capacitance for other input voltage ranges.

POUT	≤ 0.25 W	0.25 - 1 W	>1 W
85 - 265 VAC Input Stage			
	R_{F1}, R_{F2} : 100-470 Ω , 0.5 W, Fusible C_{IN} : $\geq 2.2 \mu F$, 400 V D_{IN1}, D_{IN2} : 1N4007, 1 A, 1000 V	R_{F1} : 8.2 Ω , 1 W Fusible R_{F2} : 100 Ω , 0.5 W, Flameproof C_{IN1}, C_{IN2} : $\geq 3.3 \mu F$, 400 V each D_{IN1}, D_{IN2} : 1N4007, 1 A, 1000 V	R_{F1} : 8.2 Ω , 1 W Fusible L_{IN} : 470 μH -2.2 mH, 0.05 A-0.3 A C_{IN1}, C_{IN2} : $\geq 4 \mu F/W_{OUT}$, 400 V each D_{IN1}, D_{IN2} : 1N4007, 1 A, 1000 V
Comments	*Optional for improved EMI and line surge performance. Remove for designs requiring no impedance in return rail. **Increase value to meet required differential line surge performance.		

Table 9. Recommended AC Input Stages For Universal Input.

Step 3. Determine Minimum and Maximum DC Input Voltages V_{MIN} and V_{MAX} Based on AC Input Voltage

Calculate V_{MAX} as

$$V_{MAX} = \sqrt{2} \times V_{AXMAX} \quad (1)$$

Assuming that the value of input fusible resistor is small, the voltage drop across it can be ignored.

Assume bridge diode conduction time of $t_c = 3$ ms if no other data available.

Derive minimum input voltage V_{MIN}

$$V_{MIN} = \sqrt{(2 \times V_{ACMIN}^2) - \frac{2 \times P_o \left(\frac{1}{2 \times f_L} - t_c \right)}{\eta \times C_{IN(TOTAL)}}} \quad (2)$$

If V_{MIN} is ≤ 70 V then increase value of $C_{IN(TOTAL)}$.

Step 4. Select LinkSwitch-TN Device Based on Output Current and Current Limit

Decide on the operating mode - refer to Table 7.

For MDCM operation, the output current (I_o) should be less than or equal to half the value of the minimum current limit of the chosen device from the data sheet.

$$I_{LIMIT_MIN} > 2 \times I_o \quad (3)$$

For CCM operation, the device should be chosen such that the output current I_o , is more than 50%, but less than 80% of the minimum current limit I_{LIMIT_MIN} .

$$0.5 \times I_{LIMIT_MIN} < I_o < 0.8 \times I_{LIMIT_MIN} \quad (4)$$

Please see the data sheet for LinkSwitch-TN current limit values.

Step 5. Select the Output Inductor

Tables 4 and 5 provide inductor values and RMS current ratings for common output voltages and currents based on the calculations in the design spreadsheet. Select the next nearest higher voltage and/or current above the required output specification. Alternatively, the PIXIs spreadsheet tool in the PI Expert software design suite or Appendix A can be used to calculate the exact inductor value (Eq. A7) and RMS current rating (Eq. A21).

It is recommended that the value of inductor chosen should be closer to L_{TYP} rather than $1.5 \times L_{TYP}$ due to lower DC resistance and higher RMS rating. The lower limit of 680 μ H limits the maximum di/dt to prevent very high peak current values. Tables 3 and 4 provide reference part numbers for standard inductors from two suppliers.

$$680 \mu\text{H} < L_{TYP} < L < 1.5 \times L_{TYP} \quad (5)$$

For LinkSwitch-TN designs, the mode of operation is not dependent on the inductor value. The mode of operation is a function of load current and current limit of the chosen device. The inductor value merely sets the average switching frequency.

Figure 2 shows a typical standard inductor manufacturer's data sheet. The value of off-the-shelf "drum core / dog bone / I core" inductors will drop up to 20% in value as the current increases. The constant K_{L_TOL} in equation (A7) and the design spreadsheet adjusts for both this drop and the initial inductance value tolerance.

For example if a 680 μ H, 360 mA inductor is required, referring to Figure 2, the tolerance is 10% and an estimated 9.5% for the reduction in inductance at the operating current (approximately $[0.36/0.38] \times 10$). Therefore the value of $K_{L_TOL} = 1.195$ (19.5%). If no data is available, assume a K_{L_TOL} of 1.15 (15%).

Model	Inductance L(mH/ at 10 kHz)	Rdc (Ω) max.	Current Rating		Current (Reference Value) (A) L change rate -10%
			for 20 °C Rise $\Delta T = 20 \text{ }^\circ\text{C}$	for 40 °C Rise $\Delta T = 40 \text{ }^\circ\text{C}$	
681-361	680 \pm 10%	1.62	0.36	0.50	0.38
102-281	1000 \pm 10%	2.37	0.28	0.39	0.31
152-251	1500 \pm 10%	3.64	0.25	0.35	0.26
222-191	2200 \pm 10%	5.62	0.19	0.26	0.21
332-151	3300 \pm 10%	7.66	0.15	0.21	0.17

Figure 2. Example of Standard Inductor Data Sheet.

PI-3783-121404

Not all the energy stored in the inductor is delivered to the load, due to losses in the inductor itself. To compensate for this, a loss factor K_{LOSS} is used. This has a recommended value of between 50% and 66% of the total supply losses as given by Equation 6. For example, a design with an overall efficiency (η) of 0.75 would have a K_{LOSS} value of between 0.875 and 0.833.

$$K_{LOSS} = 1 - \left(\frac{1 - \eta}{2}\right) t_o 1 - \left(\frac{2(1 - \eta)}{3}\right) \quad (6)$$

Step 6. Select Freewheeling Diode

For MDCM operation at $t_{AMB} \leq 70^\circ\text{C}$, select an ultra-fast diode with $t_{rr} \leq 75$ ns. At $t_{AMB} > 70^\circ\text{C}$, $t_{rr} \leq 35$ ns.

For CCM operation, select an ultra-fast diode with $t_{rr} \leq 35$ ns. Allowing 25% design margin for the freewheeling diode,

$$V_{PIV} > 1.25 \times V_{MAX} \quad (7)$$

The diode must be able to conduct the full load current. Thus

$$I_F > 1.25 \times I_O \quad (8)$$

Table 3 lists common freewheeling diode choices.

Step 7. Select Output Capacitor

The output capacitor should be chosen based on the output voltage ripple requirement. Typically the output voltage ripple is dominated by the capacitor ESR and can be estimated as:

$$ESR_{MAX} = \frac{V_{RIPPLE}}{I_{LIMIT}} \quad (9)$$

where V_{RIPPLE} is the maximum output ripple specification and I_{LIMIT} is the LinkSwitch-TN current limit. The capacitor ESR value should be specified approximately at the switching frequency of 66 kHz.

Capacitor values above 100 μF are not recommended as they can prevent the output voltage from reaching regulation during the 50 ms period prior to auto-restart. If more capacitance is required, then a soft-start capacitor should be added (see Other Information section).

Step 8. Select the Feedback Resistors

The values of R_{FB} and R_{BIAS} are selected such that, at the regulated output voltage, the voltage on the FEEDBACK pin (V_{FB}) is 1.65 V. This voltage is specified for a FEEDBACK pin current (I_{FB}) of 49 μA .

Let the value of $R_{BIAS} = 2 \text{ k}\Omega$; this biases the feedback network at a current of $\sim 0.8 \text{ mA}$. Hence the value of R_{FB} is given by

$$R_{FB} = \frac{V_O - V_{FB}}{\frac{V_{FB}}{R_{BIAS}} + I_{FB}} = \frac{(V_O - V_{FB}) \times R_{BIAS}}{V_{FB} + (I_{FB} \times R_{BIAS})} = \frac{(V_O - 1.65 \text{ V}) \times 2 \text{ k}\Omega}{1.748 \text{ V}} \quad (10)$$

Step 9. Select the Feedback Diode and Capacitor

For the feedback capacitor, use a 10 μF general purpose electrolytic capacitor with a voltage rating $\geq 1.25 \times V_O$.

For the feedback diode, use a glass passivated 1N4005GP or 1N4937GP device with a voltage rating of $\geq 1.25 \times V_{MAX}$.

Step 10. Select Bypass Capacitor

Use 0.1 μF , 50 V ceramic capacitor.

Step 11. Select Pre-load Resistor

For direct feedback designs, if the minimum load $< 3 \text{ mA}$, then calculate $R_{PL} = V_O / 3 \text{ mA}$.

Other information

Startup Into Non-Resistive Loads

If the total system capacitance is $> 100 \mu\text{F}$ or the output voltage is $> 12 \text{ V}$, then during startup the output may fail to reach regulation within 50 ms, triggering auto-restart operation. This may also be true when the load is not resistive, for example, the output is supplying a motor or fan. This is not applicable for the LNK302 as it does not have the auto-restart function.

To increase the startup time, a soft-start capacitor can be added across the feedback resistor, as shown in Figure 3. The value of this soft-start capacitor is typically in the range of 0.47 μF to 47 μF with a voltage rating of $1.25 \times V_O$. Figure 4 shows the effect of C_{SS} used on a 12 V, 150 mA design driving a motor load.

Generating Negative and Positive Outputs

In appliance applications there is often a requirement to generate both an AC line referenced positive and negative output. This can be accomplished using the circuit in Figure 5. The two Zener diodes have a voltage rating close to the required output voltage for each rail and ensure that regulation is maintained when one rail is lightly and the other heavily loaded. The LinkSwitch-TN circuit is designed as if it were a single output voltage with an output current equal to the sum of both outputs. The magnitude sum of the output voltages in this example being 12 V.

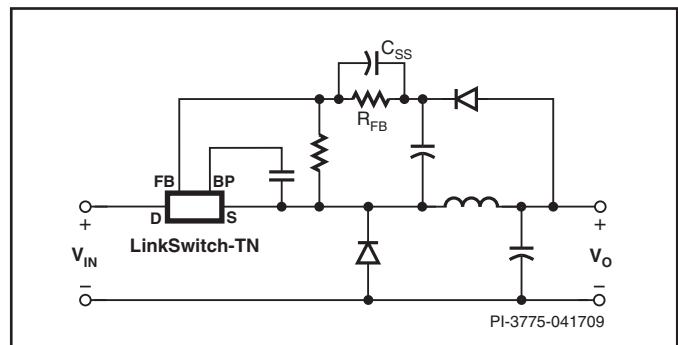

Figure 3. Example Schematic Showing Placement of Soft-Start Capacitor.

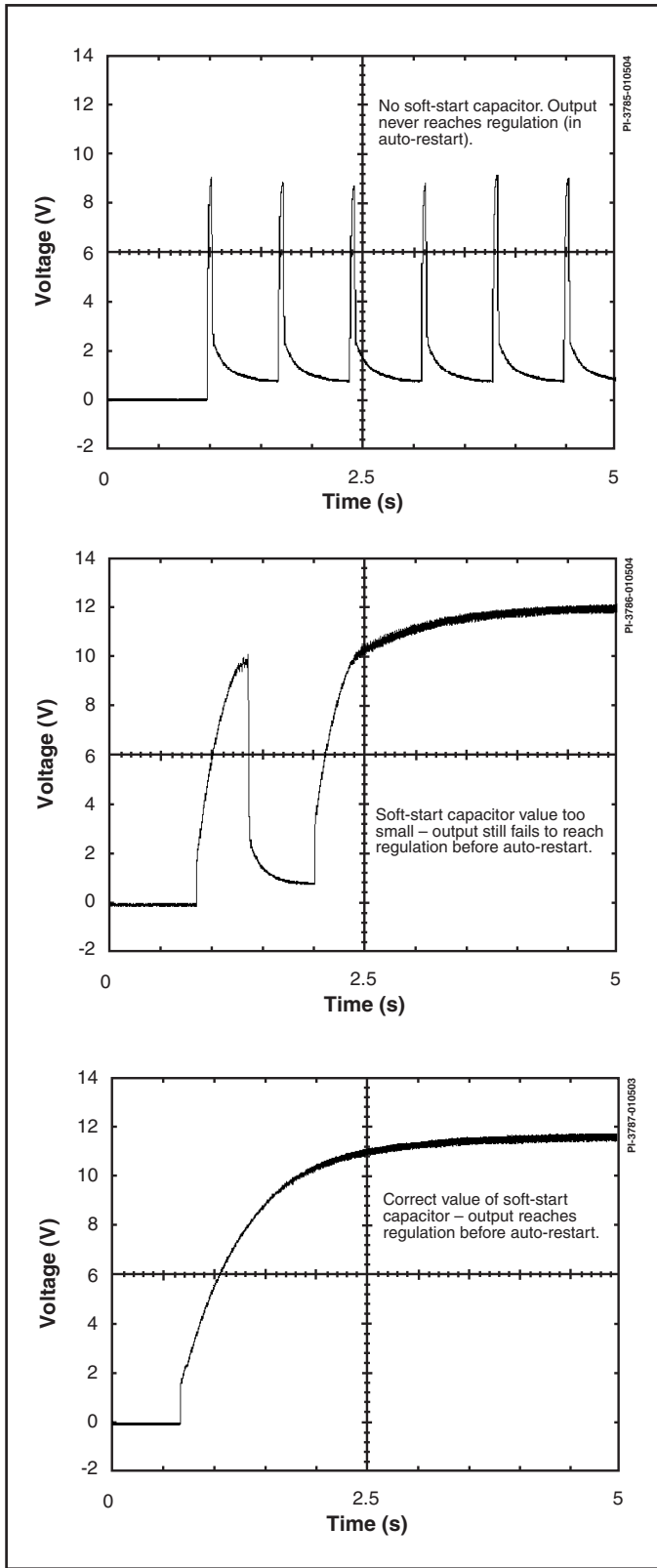

Figure 4. Example of Using a Soft-Start Capacitor to Enable Driving a 12 V, 0.15 A Motor Load. All Measurements Were Made at 85 VAC (Worst Case Condition).

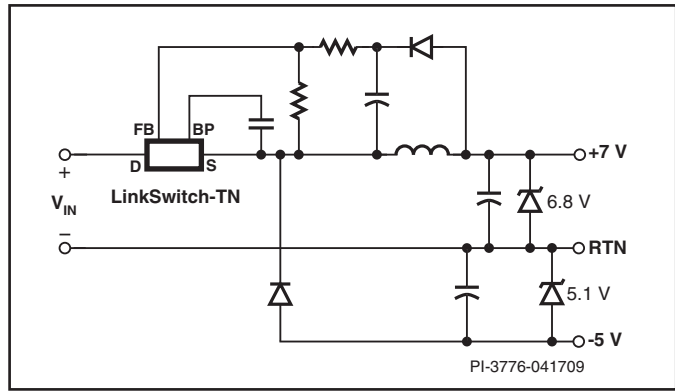

Figure 5. Example Circuit – Generating Dual Output Voltages.

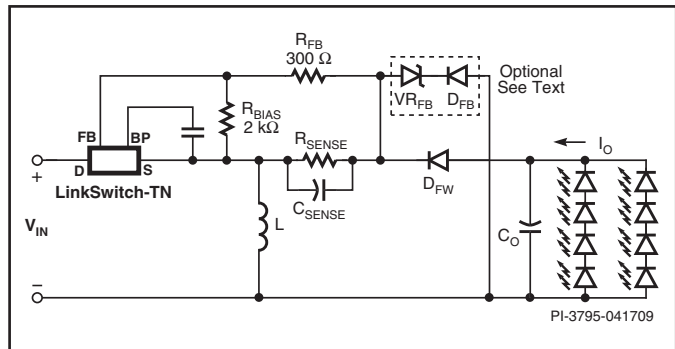

Figure 6. High-Side Buck-Boost Constant Current Output Configuration.

Constant Current Circuit Configuration (LED Driver)

The circuit shown in Figure 6 is ideal for driving constant current loads such as LEDs. It uses the tight tolerance and temperature stable FEEDBACK pin of LinkSwitch-TN as the reference to provide an accurate output current.

To generate a constant current output, the average output current is converted to a voltage by resistor R_{SENSE} and capacitor C_{SENSE} and fed into the FEEDBACK pin via R_{FB} and R_{BIAS} .

With the values of R_{BIAS} and R_{FB} as shown, the value of R_{SENSE} should be chosen to generate a voltage drop of 2 V at the required output current. Capacitor C_{SENSE} filters the voltage across R_{SENSE} , which is modulated by inductor ripple current. The value of C_{SENSE} should be large enough to minimize the ripple voltage, especially in MDCM designs. A value of C_{SENSE} is selected such that the time constant (t) of R_{SENSE} and C_{SENSE} is greater than 20 times that of the switching period (15 μ s). The peak voltage seen by C_{SENSE} is equal to $R_{SENSE} \times I_{LIMIT(MAX)}$.

The output capacitor is optional; however with no output capacitor the load will see the full peak current (I_{LIMIT}) of the selected LinkSwitch-TN. Increase the value of C_O (typically in the range of 100 nF to 10 μ F) to reduce the peak current to an acceptable level for the load.

If the load is disconnected, feedback is lost and the large output voltage which results may cause circuit failure. To prevent this, a second voltage control loop, D_{FB} and VR_{FB} , can be added as shown in Figure 6. This also requires that C_O is fitted. The voltage of the Zener is selected as the next standard value above the maximum voltage across the LED string when it is in constant current operation.

The same design equations / design spreadsheet can be used as for a standard buck-boost design, with the following additional considerations.

1. $V_O = LED V_F \times \text{Number of LEDs per string}$
2. $I_O = LED I_F \times \text{Number of strings}$
3. Lower efficiency estimate due to R_{SENSE} losses (enter R_{SENSE} into design spreadsheet as inductor resistance)
4. Set $R_{BIAS} = 2 \text{ k}\Omega$ and $R_{FB} = 300 \Omega$
5. $R_{SENSE} = 2/I_O$
6. $C_{SENSE} = 20 \times (15 \mu\text{s}/R_{SENSE})$
7. Select C_O based on acceptable output ripple current through the load
8. If the load can be disconnected or for additional fault protection, add voltage feedback components D_{FB} and VR_{FB} , in addition to C_O .

Thermal Environment

To ensure good thermal performance, the SOURCE pin temperature should be maintained below 100 °C, by providing adequate heatsinking.

For applications with high ambient temperature (>50 °C), it is recommended to build and test the power supply at the maximum operating ambient temperature and ensure that there is adequate thermal margin. The figures for maximum output current provided in the data sheet correspond to an ambient temperature of 50 °C and may need to be thermally derated. Also, it is recommended to use ultra-fast ($\leq 35 \text{ ns}$) low reverse recovery diodes at higher operating temperatures (>70 °C).

Recommended Layout Considerations

Traces carrying high currents should be as short in length and thick in width as possible. These are the traces which connect the input capacitor, LinkSwitch-TN, inductor, freewheeling diode, and the output capacitor.

Most off-the-shelf inductors are drum core inductors or dog-bone inductors. These inductors do not have a good closed magnetic path, and are a source of significant magnetic coupling. They are a source of differential mode noise and, for this reason, they should be placed as far away as possible from the AC input lines.

Appendix A

Calculations for Inductor Value for Buck and Buck-Boost Topologies

There is a minimum value of inductance that is required to deliver the specified output power, regardless of line voltage and operating mode.

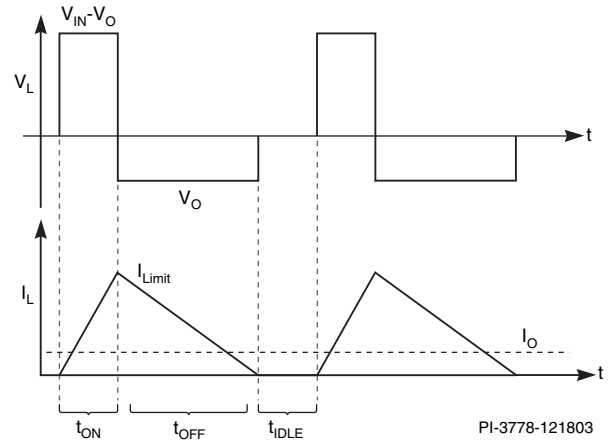

Table 7. Inductor Voltage and Inductor Current of a Buck Converter in DCM.

As a general case, Figure 7 shows the inductor current in discontinuous conduction mode (DCM). The following expressions are valid for both CCM as well as DCM operation. There are three unique intervals in DCM as can be seen from Figure 7. Interval t_{ON} is when the LinkSwitch-TN is ON and the freewheeling diode is OFF. Current ramps up in the inductor from an initial value of zero. The peak current is the current limit I_{LIMIT} of the device. Interval t_{OFF} is when the LinkSwitch-TN is OFF and the freewheeling diode is ON. Current ramps down to zero during this interval. Interval t_{IDLE} is when both the LinkSwitch-TN and freewheeling diode are OFF, and the inductor current is zero.

In CCM, this idle state does not exist and thus $t_{IDLE} = 0$.

Neglecting the forward voltage drop of the freewheeling diode, we can express the current swing at the end of interval t_{ON} in a buck converter as

$$\Delta I(t_{ON}) = I_{RIPPLE} = \frac{V_{MIN} - V_{DS} - V_O}{L_{MIN}} \times t_{ON}$$

$$I_{RIPPLE} = 2 \times (I_{LIMIT_MIN} - I_O) t_{IDLE} = 0 \text{ (for CCM)}$$

$$I_{RIPPLE} = I_{LIMIT_MIN}, \quad t_{IDLE} > 0 \text{ (for CCM)} \tag{A1}$$

where

- I_{RIPPLE} = Inductor ripple current
- I_{LIMIT_MIN} = Minimum current limit
- V_{MIN} = Minimum DC bus voltage
- V_{DS} = On state drain to source voltage drop
- V_O = Output voltage
- L_{MIN} = Minimum inductance

Similarly, we can express the current swing at the end of interval t_{OFF} as

$$\Delta I(t_{OFF}) = I_{RIPPLE} = \frac{V_O}{L_{MIN}} \times t_{OFF} \tag{A2}$$

The initial current through the inductor at the beginning of each switching cycle can be expressed as

$$I_{INITIAL} = I_{LIMIT_MIN} - I_{RIPPLE} \tag{A3}$$

The average current through the inductor over one switching cycle is equal to the output current I_O . This current can be expressed as

$$I_O = \frac{1}{T_{SW_MAX}} \left(\frac{1}{2} \times (I_{LIMIT_MIN} + I_{INITIAL}) \times t_{ON} + \frac{1}{2} \times (I_{LIMIT_MIN} + I_{INITIAL}) \times t_{OFF} + 0 \times t_{IDLE} \right) \quad (A4)$$

where

I_O = Output current.

T_{SW_MAX} = The switching interval corresponding to minimum switching frequency FS_{MIN} .

Substituting for t_{ON} and t_{OFF} from equations (A1) and (A2) we have

$$I_O = \frac{1}{T_{SW_MAX}} \left(\frac{1}{2} \times (I_{LIMIT_MIN} + I_{INITIAL}) \frac{I_{RIPPLE} \times L_{MIN}}{V_{MIN} - V_{DS} - V_O} + \frac{1}{2} \times (I_{LIMIT_MIN} + I_{INITIAL}) \frac{I_{RIPPLE} \times L_{MIN}}{V_O} \right) \quad (A5)$$

$$I_{LIM} = \frac{2 \times (V_O \times I_O) \times (V_{MIN} - V_{DS} - V_O)}{(I_{LIMIT_MIN}^2 - I_{INITIAL}^2) \times FS_{MIN} \times (V_{MIN} - V_{DS})} \quad (A6)$$

For output voltages greater than 20 V, use V_{MAX} for calculation of L_{MIN} (Equation A6). For output voltages less than 20 V, use V_{MIN} for calculation of L_{MIN} to compensate for current limit delay time overshoot.

This however does not account for the losses within the inductor (resistance of winding and core losses) and the freewheeling diode, which will limit the maximum power delivering capability and thus reduce the maximum output current. The minimum inductance must compensate for these losses in order to deliver specified full load power. An estimate of these losses can be made by estimating the total losses in the power supply, and then allocating part of these losses to the inductor and diode. This is done by the loss factor K_{LOSS} which increases the size of the inductor accordingly.

Furthermore, typical inductors for this type of application are bobbin core or dog bone chokes. The specified current rating refer to a temperature rise of 20 °C or 40 °C and to an inductance drop of 10%. We must incorporate an inductance tolerance factor K_{L_TOL} within the expression for minimum inductance, to account for this manufacturing tolerance. The typical inductance value thus can be expressed as

$$L_{TYP} = \frac{2 \times K_{L_TOL} \times \left(\frac{V_O \times I_O}{K_{LOSS}} \right) \times (V_{MIN} - V_{DS} - V_O)}{(I_{LIMIT_MIN}^2 - I_{INITIAL}^2) \times FS_{MIN} \times (V_{MIN} - V_{DS})} \quad (A7)$$

where

K_{LOSS} is a loss factor, which accounts for the off-state total losses of the inductor.

K_{L_TOL} is the inductor tolerance factor and can be between 1.1 and 1.2. A typical value is 1.15.

With this typical inductance we can express maximum output power as

$$P_{O_MAX} = \frac{1}{2} \times L_{TYP} \times (I_{LIMIT_MIN}^2 - I_{INITIAL}^2) \times FS_{MIN} \times \frac{V_{MIN} - V_{DS}}{V_{MIN} - V_{DS} - V_O} \times \frac{K_{LOSS}}{K_{L_TOL}} \quad (A8)$$

Similarly for buck-boost topology the expressions for L_{TYP} and P_{O_MAX} are

$$L_{TYP} = \frac{2 \times K_{L_TOL} \times \left(\frac{V_O \times I_O}{K_{LOSS}} \right)}{(I_{LIMIT_MIN}^2 - I_{INITIAL}^2) \times FS_{MIN}} \quad (A9)$$

$$P_{O_MAX} = \frac{1}{2} \times L_{TYP} \times (I_{LIMIT_MIN}^2 - I_{INITIAL}^2) \quad (A10)$$

Average Switching Frequency

Since LinkSwitch-TN uses an on-off type of control, the frequency of switching is non-uniform due to cycle skipping. We can average this switching frequency by substituting the maximum power as the output power in Equation A8. Simplifying, we have

$$FS_{AVG} = \frac{2 \times V_O \times I_O \times K_{L_TOL}}{L \times (I_{LIMIT}^2 - I_{INITIAL}^2) K_{LOSS}} \times \frac{V_{MIN} - V_{DS} - V_O}{V_{MIN} - V_{DS}} \quad (A11)$$

Similarly for buck-boost converter, simplifying Equation A9 we have

$$FS_{AVG} = \frac{2 \times V_O \times I_O}{L \times (I_{LIMIT}^2 - I_{INITIAL}^2) K_{LOSS}} \times \frac{K_{L_TOL}}{K_{LOSS}} \quad (A12)$$

Calculation of RMS Currents

The RMS current value through the inductor is mainly required to ensure that the inductor is appropriately sized and will not overheat. Also, RMS currents through the LinkSwitch-TN and freewheeling diode are required to estimate losses in the power supply.

Assuming CCM operation, the initial current in the inductor in steady state is given by

$$I_{INITIAL} = I_{LIMIT_MIN} - \frac{V_O}{L} \times t_{OFF} \quad (A13)$$

For DCM operation this initial current will be zero.

The current through the LinkSwitch-TN as a function of time is given by

$$i_{SW}(t) = I_{INITIAL} + \frac{V_{MIN} - V_{DS} - V_O}{L} \times t, 0 < t \leq t_{ON}$$

$$i_{SW}(t) = 0, t_{ON} < t \leq t_{ON} \quad (A14)$$

The current through the freewheeling diode as a function of time is given by

$$i_D(t) = 0, 0 < t \leq t_{ON}$$

$$i_D(t) = I_{LIMIT_MIN} - \frac{V_O}{L}, t_{ON} < t \leq t_{SW} \quad (A15)$$

$$i_D(t) = 0, I_{LIMIT_MIN} - \frac{V_O}{L} \times t < 0 \quad (A16)$$

And the current through the inductor as a function of time is given by

$$i_L(t) = i_{SW}(t) + i_D(t) \quad (A17)$$

From the definition of RMS currents we can express the RMS

currents through the switch, freewheeling diode and inductor as follows

$$i_{SW_RMS} = \sqrt{\frac{1}{T_{AVG}} \int_0^{t_{ON}} i_{SW}(t)^2 \times dt} \quad (A18)$$

$$i_{D_RMS} = \sqrt{\frac{1}{T_{AVG}} \int_{t_{ON}}^{t_{ON}+t_{OFF}} i_D(t)^2 \times dt} \quad (A19)$$

$$i_{L_RMS} = \sqrt{\frac{1}{T_{AVG}} \int_0^{T_{AVG}} (i_{SW}(t) + i_D(t))^2 \times dt} \quad (A20)$$

Since the switch and freewheeling diode currents fall to zero during the turn off and turn on intervals respectively, the RMS inductor current is simplified to

$$i_{L_RMS} = \sqrt{i_{SW_RMS}^2 + i_{D_RMS}^2} \quad (A21)$$

Table A1 lists the design equations for important parameters using the buck and buck-boost topologies.

Parameter	Buck	Buck-Boost
L_{TYP}	$L_{TYP} = \frac{2 \times K_L \times \left(\frac{V_O \times I_O}{K_{L_LOSS}}\right) \times (V_{MIN} - V_{DS} - V_O)}{(I_{LIMIT_MIN}^2 - I_{INITIAL}^2) \times FS_{MIN} \times (V_{MIN} - V_{DS})}$	$L_{TYP} = \frac{2 \times K_L \times \left(\frac{V_O \times I_O}{K_{L_LOSS}}\right)}{(I_{LIMIT_MIN}^2 - I_{INITIAL}^2) \times FS_{MIN}}$
F_{AVG}	$FS_{TYP} = \frac{2 \times V_O \times I_O \times K_L}{L \times (I_{LIMIT}^2 - I_{INITIAL}^2) \times K_{L_LOSS}} \times \frac{V_{MIN} - V_{DS} - V_O}{V_{MIN} - V_{DS}}$	$FS_{AVG} = \frac{2 \times V_O \times I_O}{L \times (I_{LIMIT}^2 - I_{INITIAL}^2)} \times \frac{K_L}{K_{L_LOSS}}$
$i_{SW}(t)$ LinkSwitch-TN Current	$i_{SW}(t) = i_{INT} + \frac{V_{MIN} - V_{DS} - V_O}{L} \times t, t \leq t_{ON}$ $i_{SW}(t) = 0, t > t_{ON}$	$i_{SW}(t) = I_{INT} + \frac{V_{MIN} - V_{DS}}{L} \times t, t \leq t_{ON}$ $i_{SW}(t) = 0, t > t_{ON}$
$i_D(t)$ Diode Forward Current	$i_D(t) = I_{LIMIT_MIN} - \frac{V_O}{L} \times t, t > t_{ON}$ $i_D(t) = 0, I_{LIMIT_MIN} - \frac{V_O}{L} \times t < 0$ $i_D(t) = 0, t \leq t_{ON}$	$i_D(t) = I_{LIMIT_MIN} - \frac{V_O}{L} \times t, t > t_{ON}$ $i_D(t) = 0, I_{LIMIT_MIN} - \frac{V_O}{L} \times t < 0$ $i_D(t) = 0, t \leq t_{ON}$
$i_L(t)$ Inductor Current	$i_L(t) = i_{SW}(t) + i_D(t)$	$i_L(t) = i_{SW}(t) + i_D(t)$
Max Drain Voltage	V_{MAX}	$V_{MAX} + V_O$

Table A1. Circuit Characteristics for Buck and Buck-Boost Topologies.

Revision	Notes	Date
A	Initial Release	01/04
B	Corrected Tables 3 and 4.	04/04
C	Added LNK302.	07/04
D	Added supplementary information to Tables 4 and 5.	12/04
E	Corrected equation 2.	05/05
F	Updated Key Features column in Table 1.	04/09

For the latest updates, visit our website: www.powerint.com

Power Integrations reserves the right to make changes to its products at any time to improve reliability or manufacturability. Power Integrations does not assume any liability arising from the use of any device or circuit described herein. POWER INTEGRATIONS MAKES NO WARRANTY HEREIN AND SPECIFICALLY DISCLAIMS ALL WARRANTIES INCLUDING, WITHOUT LIMITATION, THE IMPLIED WARRANTIES OF MERCHANTABILITY, FITNESS FOR A PARTICULAR PURPOSE, AND NON-INFRINGEMENT OF THIRD PARTY RIGHTS.

Patent Information

The products and applications illustrated herein (including transformer construction and circuits external to the products) may be covered by one or more U.S. and foreign patents, or potentially by pending U.S. and foreign patent applications assigned to Power Integrations. A complete list of Power Integrations patents may be found at www.powerint.com. Power Integrations grants its customers a license under certain patent rights as set forth at <http://www.powerint.com/ip.htm>.

Life Support Policy

POWER INTEGRATIONS PRODUCTS ARE NOT AUTHORIZED FOR USE AS CRITICAL COMPONENTS IN LIFE SUPPORT DEVICES OR SYSTEMS WITHOUT THE EXPRESS WRITTEN APPROVAL OF THE PRESIDENT OF POWER INTEGRATIONS. As used herein:

1. A Life support device or system is one which, (i) is intended for surgical implant into the body, or (ii) supports or sustains life, and (iii) whose failure to perform, when properly used in accordance with instructions for use, can be reasonably expected to result in significant injury or death to the user.
2. A critical component is any component of a life support device or system whose failure to perform can be reasonably expected to cause the failure of the life support device or system, or to affect its safety or effectiveness.

The PI logo, TOPSwitch, TinySwitch, LinkSwitch, DPA-Switch, PeakSwitch, EcoSmart, Clampless, E-Shield, Filterfuse, StakFET, PI Expert and PI FACTS are trademarks of Power Integrations, Inc. Other trademarks are property of their respective companies.

©2009, Power Integrations, Inc.

Power Integrations Worldwide Sales Support Locations

World Headquarters

5245 Hellyer Avenue
San Jose, CA 95138, USA.
Main: +1-408-414-9200
Customer Service:
Phone: +1-408-414-9665
Fax: +1-408-414-9765
e-mail: usasales@powerint.com

China (Shanghai)

Room 1601/1610, Tower 1
Kerry Everbright City
No. 218 Tianmu Road West
Shanghai, P.R.C. 200070
Phone: +86-21-6354-6323
Fax: +86-21-6354-6325
e-mail: chinasales@powerint.com

China (Shenzhen)

Rm A, B & C 4th Floor, Block C,
Electronics Science and
Technology Bldg., 2070
Shennan Zhong Rd,
Shenzhen, Guangdong,
China, 518031
Phone: +86-755-8379-3243
Fax: +86-755-8379-5828
e-mail: chinasales@powerint.com

Germany

Rüeckertstrasse 3
D-80336, Munich
Germany
Phone: +49-89-5527-3910
Fax: +49-89-5527-3920
e-mail: eurosales@powerint.com

India

#1, 14th Main Road
Vasanthanagar
Bangalore-560052 India
Phone: +91-80-4113-8020
Fax: +91-80-4113-8023
e-mail: indiasales@powerint.com

Italy

Via De Amicis 2
20091 Bresso MI
Italy
Phone: +39-028-928-6000
Fax: +39-028-928-6009
e-mail: eurosales@powerint.com

Japan

Kosei Dai-3 Bldg.
2-12-11, Shin-Yokomana,
Kohoku-ku
Yokohama-shi Kanagwan
222-0033 Japan
Phone: +81-45-471-1021
Fax: +81-45-471-3717
e-mail: japansales@powerint.com

Korea

RM 602, 6FL
Korea City Air Terminal B/D, 159-6
Samsung-Dong, Kangnam-Gu,
Seoul, 135-728, Korea
Phone: +82-2-2016-6610
Fax: +82-2-2016-6630
e-mail: koreasales@powerint.com

Singapore

51 Newton Road
#15-08/10 Goldhill Plaza
Singapore, 308900
Phone: +65-6358-2160
Fax: +65-6358-2015
e-mail: singaporesales@powerint.com

Taiwan

5F, No. 318, Nei Hu Rd., Sec. 1
Nei Hu Dist.
Taipei, Taiwan 114, R.O.C.
Phone: +886-2-2659-4570
Fax: +886-2-2659-4550
e-mail: taiwansales@powerint.com

Europe HQ

1st Floor, St. James's House
East Street, Farnham
Surrey GU9 7TJ
United Kingdom
Phone: +44 (0) 1252-730-141
Fax: +44 (0) 1252-727-689
e-mail: eurosales@powerint.com

Applications Hotline

World Wide +1-408-414-9660

Applications Fax

World Wide +1-408-414-9760
