

DI-18 Design Idea

LinkSwitch®

Low Cost 2.75 W CV/CC Charger or Adapter

Application	Device	Power Output	Input Voltage	Output Voltage	Topology
Charger/Adapter	LNK501PN	2.75 W	85 – 265 VAC	5.5 V	Flyback

Design Highlights

- Replaces a linear transformer based supply at the same or lower cost but with much higher performance
- <0.3 W consumption at zero load meets worldwide guidelines (EC's 0.3 W, USA's 1 W for example)
- Extremely simple circuit – only 17 components (14 with integrated bridge) for production-worthy design
- Primary based CV/CC output – no secondary sense components required
- ±10% output voltage and ±20% output current tolerances at peak power point
- Fully protected for thermal, short circuit and open loop faults
- >70% efficiency
- Meets CISPR22B/EN55022B and FCC B EMI limits
- Meets 2.5 kV EN61000-4-5 differential surge
- Ultra-low leakage current design <5 μA
- EE13 core for low cost and small size

Operation

The AC input is rectified and filtered by D1-D4, C1 and C2. Conducted EMI filtering is provided both by a π filter (C1, L1 and C2) and a differential filter (RF1 and C1). Together with a shield in

the transformer (formed from part of the primary) the design meets conducted EMI limits with no Y-capacitor between primary and secondary. Resistor RF1 also functions as a fuse.

LinkSwitch derives all feedback information from the primary. During output diode conduction, the output voltage transformed through the turns ratio is sampled and held by C4. The feedback voltage across C4 (V_{OR}) is converted into feedback current by R1 and fed into the CONTROL pin. This feedback current regulates the output by PWM control during CV operation, and by reducing the internal current limit during CC operation. Below an output voltage of ~2 V LinkSwitch enters auto-restart, limiting average output current to <50 mA. The nominal transition from CV to CC occurs at 5.5 V, 0.5 A. The output envelope characteristic and specification limits are shown in Figure 2.

Together with D5, C4 and R1 are also part of the primary clamp, limiting the peak drain to source voltage due to leakage inductance. Resistor R2 filters the leading edge leakage inductance spike, reducing the error in the feedback voltage. The CONTROL pin capacitor C3 provides energy storage for supply startup and sets auto-restart timing during fault conditions.

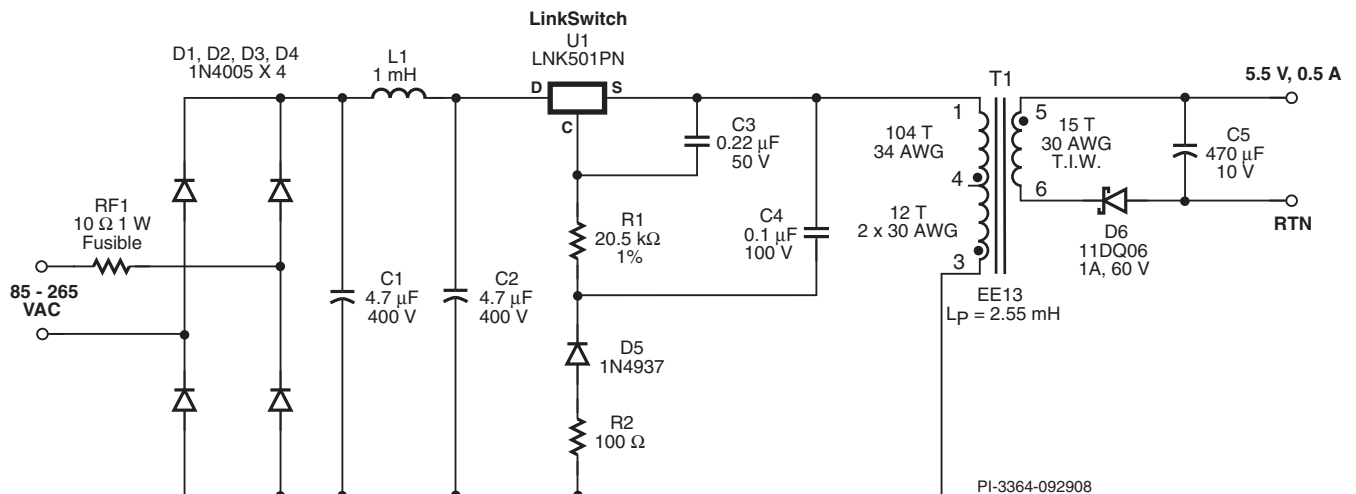

Figure 1. LinkSwitch 2.75 W Charger Power Supply.

Key Design Points

- Select transformer turns ratio to give a V_{OR} of 40-60 V. Lower values reduce power capability, higher values increase no-load consumption.
- R1 provides 2.3 mA into the CONTROL pin at the peak power point at 85 VAC. The value can be adjusted to center the output voltage.
- To maintain the $\pm 20\%$ CC tolerance the primary inductance tolerance should be tighter than $\pm 10\%$.
- Minimize zero load consumption by reducing drain node capacitance: Use double coated/grade 2 wire for primary and do not vacuum impregnate. Avoid using an RC snubber across the output diode.
- For resistive loads increase C3 to 1 μ F (electrolytic) to allow adequate time for start-up at full load.
- For battery loads an output π filter is typically not required but can be added for resistive loads to reduce switching ripple.
- L1 can be replaced with a 22 Ω to 100 Ω fusible resistor for lower cost but lower efficiency ($\sim 10\%$ reduction).
- Adding a 1 mA to 2 mA pre-load reduces zero load voltage by ~ 1 V but increases power consumption by ~ 10 mW.
- Diode D6 can be replaced with a PN diode for lower cost but reduced efficiency.
- See AN-35 and EPR-16 for more information.

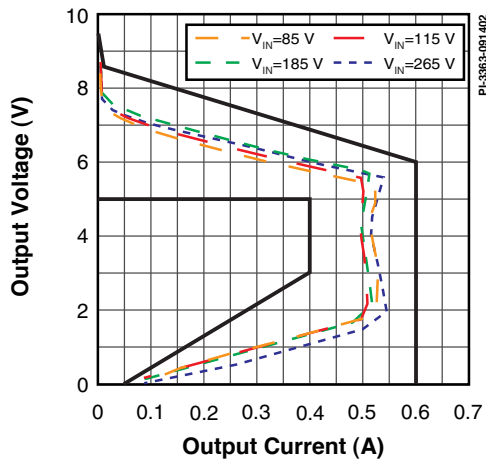

Figure 2. Load Regulation - CV/CC Characteristics with Limits.

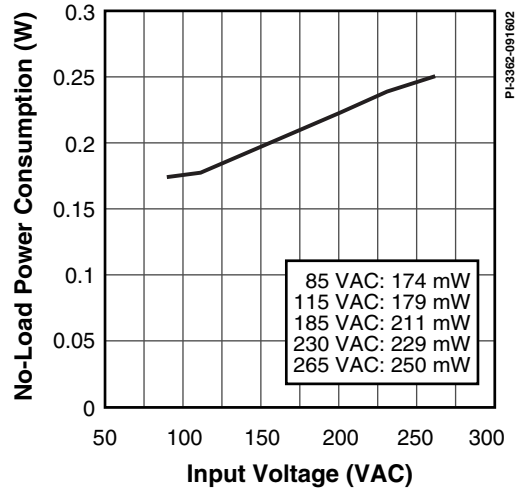

Figure 3. No-load Input Power Consumption.

Transformer Parameters

Core Material	TDK PC40 EE13, ALG = 190 nH/t ²
Bobbin	EE13 Horizontal 8 pin
Winding Details	Primary: 104T, 34 AWG Shield: 12T, 2 x 30 AWG Secondary: 15T, 30 AWG T.I.W. Flux Band: 1T, 6 mm Cu foil
Winding Order (pin numbers)	Secondary (5-6), tape, Shield (3-4), tape, Primary (4-1), tape, Flux band (3-NC)
Inductance	Primary: 2.55 mH, $\pm 10\%$ Leakage: 50 μ H (maximum)
Primary Resonant Frequency	300 kHz (minimum)

Table 1. Transformer Parameters. (AWG = American Wire Gauge, T.I.W. = Triple Insulated Wire, NC = No Connection)

Power Integrations
5245 Hellyer Avenue
San Jose, CA 95138, USA.
Main: +1 408-414-9200
Customer Service
Phone: +1-408-414-9665
Fax: +1-408-414-9765
Email: usasales@powerint.com

On the Web
www.powerint.com

Power Integrations reserves the right to make changes to its products at any time to improve reliability or manufacturability. Power Integrations does not assume any liability arising from the use of any device or circuit described herein. POWER INTEGRATIONS MAKES NO WARRANTY HEREIN AND SPECIFICALLY DISCLAIMS ALL WARRANTIES INCLUDING, WITHOUT LIMITATION, THE IMPLIED WARRANTIES OF MERCHANTABILITY, FITNESS FOR A PARTICULAR PURPOSE, AND NON-INFRINGEMENT OF THIRD PARTY RIGHTS. The products and applications illustrated herein (transformer construction and circuits external to the products) may be covered by one or more U.S. and foreign patents or potentially by pending U.S. and foreign patent applications assigned to Power Integrations. A complete list of Power Integrations' patents may be found at www.powerint.com. Power Integrations grants its customers a license under certain patent rights as set forth at <http://www.powerint.com/ip.htm>.

The PI logo, TOPSwitch, TinySwitch, LinkSwitch, DPA-Switch, PeakSwitch, EcoSmart, Clampless, E-Shield, Filterfuse, StackFET, PI Expert and PI FACTS are trademarks of Power Integrations, Inc. Other trademarks are property of their respective companies. ©2002, Power Integrations, Inc.