

DI-151 Design Idea PeakSwitch®

Audio Amplifier Power Supply

Application	Device	Power Output	Input Voltage	Output Voltage	Topology
Audio	PKS605PN	24 W, 36 W peak	90 – 265 VAC	12 V	Flyback

Design Highlights

- Universal input voltage range
- Efficiency meets CEC/ENERGY STAR requirements for 2008
 - Efficiency 80% (vs. 78% requirement)
 - Low no-load power consumption less than 150 mW
- Meets CISPR-22/EN55022 B conducted EMI limits with >10 dB μ V margin (see Figure 3)
- Integrated safety/reliability features:
 - Accurate, auto-recovering, hysteretic thermal shutdown function maintains safe PCB temperatures under all conditions
 - Auto-restart protects against output short circuits and open feedback loops

Operation

The isolated flyback converter in Figure 1 shows a universal input, 12 V, 2 A (24 W) power supply that is capable of delivering up to 36 W of peak power for short periods. Differential EMI filtering is provided by C1, C2, C10 and L1. Common mode EMI filtering is provided by L1, L2, C8 and C13.

Capacitor C3 decouples the BYPASS (BP) pin (which is the IC's internally regulated supply node) of U1. A bias winding on the transformer T1 (pins 4 and 5), D6, C5 and R3 is used to provide operating current to U1 after startup.

The clamp circuit is formed by D5, R2, R9, C4 and VR2. When the MOSFET turns off, the leakage inductance of the transformer induces a voltage spike on the drain node. The amplitude of the spike is limited by capacitor C4. Resistors R9 and VR3 conduct every cycle and discharge capacitor C4. The benefit of this arrangement is that during low frequency operation (light loads), the capacitor discharge is limited to the voltage of VR2, and the no-load efficiency is improved. Resistor R2 damps out excessive ringing due to resonance between leakage inductance of T1 and C4 when diode D5 conducts.

Optocoupler feedback using a simple, low-cost Zener reference diode provides output regulation. A feedback current proportional to the output voltage flows through the optocoupler diode (U2A). On the primary side, phototransistor (U2B) drives a small signal transistor Q2, which in turn pulls current out of the EN/UV pin. Just before the start of each cycle, the PeakSwitch controller checks this EN/UV pin current. If this current exceeds 240 μ A, switching cycle is disabled for that cycle.

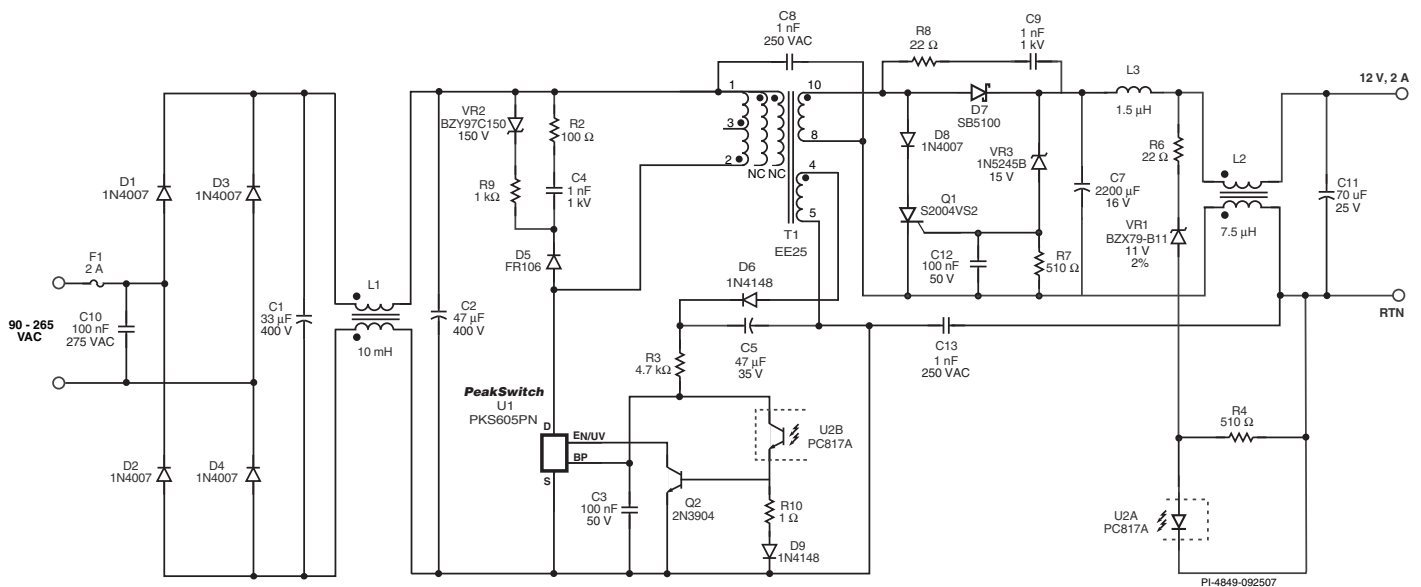

Figure 1. 24 W Continuous, 36 W Peak Audio Amplifier Power Supply, Designed Around a PKS605PN.

Key Design Points

- It is possible to design for higher peak output power with the same transformer core if the duration of peak power requirement is shorter.
- Output overvoltage protection (OVP) is provided by the crowbar circuit (D8, Q1, VR3, C12 and R7). Capacitor C12 and R7 provide a delay to prevent spurious turn-on of thyristor Q1.
- Transistor Q2 and associated circuitry (R10, D9) are used to increase the gain of the optocoupler and reduce grouping of consecutively enabled or disabled switching cycles.
- Use a fast blocking diode (D5) such as the FR106 or FR107 in the clamp circuit. Ensure that the diode has a reverse recovery time of 500 ns or less. These slower diodes can effectively recycle some of the clamp energy stored in C4, thus improving no-load efficiency.
- An external heatsink was used to reduce temperature rise on U1.
- The core size and the winding wire diameter sizes (see Table 1) were chosen based on the average of the peak and the continuous output power.
- The number of turns in the primary and secondary windings and the primary inductance values (see Table 1) was chosen based on the peak output power.

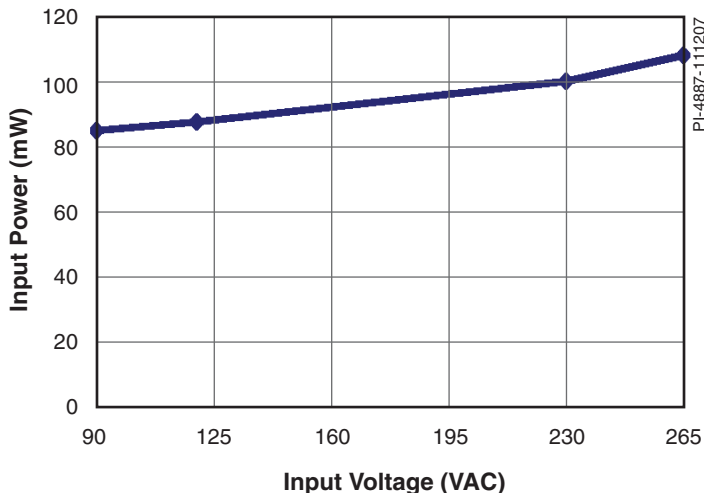

Figure 2. No-load Input Power vs AC Input Voltage.

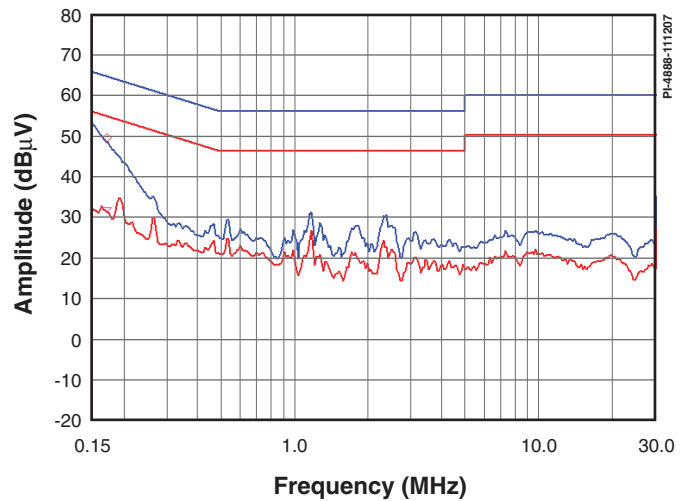

Figure 3. Worst Case Conducted EMI Measured at 230 VAC With Output Grounded.

Transformer Parameters

Core Material	EE25 NC-2H or equivalent, gapped for ALG of 148 nH/t ²
Bobbin	EE25, 10 pin, Vertical
Winding Details	Bias: 6T × 4, AWG28, tape ½ Primary: 20T × 1, AWG25, tape Shield: 1T Copper Foil 2 mils thick, 3 layers tape 32 V: 5T × 2, AWG23, TIW, 3 layers tape Shield: 1T Copper Foil 2 mils thick, tape ½ Primary: 20T × 1, AWG25, 2 layers tape
Winding Order	Bias (4–5), Primary (2–3), Shield (1-NC), 12 V (10-8), Shield (1-NC), Primary (3–1)
Primary Inductance	280 µH, ±5%
Primary Resonant Frequency	1.2 MHz (minimum)
Leakage Inductance	4.5 µH (maximum)

Table 1. Transformer Parameters. (TIW = Triple Insulated Wire, NC = No Connection)

Power Integrations
5245 Hellyer Avenue
San Jose, CA 95138, USA.
Main: +1 408-414-9200
Customer Service
Phone: +1-408-414-9665
Fax: +1-408-414-9765
Email: usasales@powerint.com

On the Web
www.powerint.com

Power Integrations reserves the right to make changes to its products at any time to improve reliability or manufacturability. Power Integrations does not assume any liability arising from the use of any device or circuit described herein. POWER INTEGRATIONS MAKES NO WARRANTY HEREIN AND SPECIFICALLY DISCLAIMS ALL WARRANTIES INCLUDING, WITHOUT LIMITATION, THE IMPLIED WARRANTIES OF MERCHANTABILITY, FITNESS FOR A PARTICULAR PURPOSE, AND NON-INFRINGEMENT OF THIRD PARTY RIGHTS. The products and applications illustrated herein (transformer construction and circuits external to the products) may be covered by one or more U.S. and foreign patents or potentially by pending U.S. and foreign patent applications assigned to Power Integrations. A complete list of Power Integrations' patents may be found at www.powerint.com. Power Integrations grants its customers a license under certain patent rights as set forth at <http://www.powerint.com/ip.htm>.

The PI logo, TOPSwitch, TinySwitch, LinkSwitch, DPA-Switch, PeakSwitch, EcoSmart, Clampless, E-Shield, Filterfuse, StackFET, PI Expert and PI FACTS are trademarks of Power Integrations, Inc. Other trademarks are property of their respective companies. ©2007, Power Integrations, Inc.