

DI-133 Design Idea

LinkSwitch-XT[®]

Non-Isolated Induction Cooktop Auxiliary Supply

Application	Device	Power Output	Input Voltage	Output Voltage	Topology
Induction Cooktop	LNK364PN	5.9 W	185 – 265 VAC	5 V, 100 mA / 18 V, 300 mA	Flyback

Design Highlights

- Low cost, low component count solution: only 17 parts
- Both outputs exhibit good cross regulation
- <130 mW no-load power consumption at 265 VAC
- Meets CEC active mode efficiency with good margin

Operation

The non-isolated flyback converter shown in Figure 1 was designed around a member of the LinkSwitch-XT IC family, the LNK364PN (U1). Its dual outputs (5 V for the display and 18 V for the fan and IGBT control circuit) can provide up to 5.9 W of power at the lowest input line voltage (185 VAC).

Since the cooktop has conducted EMI filtering for the induction heating converter, this auxiliary supply requires no fuse or filter components. Diode D1 half-wave rectifies the AC input and capacitor C1 filters it to produce the high-voltage DC bus that feeds transformer T1. An RCD clamp (C2, D3, R1 and R2) across the primary winding of T1 limits the amplitude of the leakage-inductance voltage spike that occurs each time the integrated power MOSFET within U1 switches off.

A high-voltage current source within U1 feeds current into bypass capacitor C3, during the MOSFET off-time. Capacitor C3 develops the operating voltage for the IC and supplies the normal operating current to the chip.

Due to the phasing of T1's windings and the locations and orientations of the output diodes (D4 and D5), no secondary current flows while the MOSFET is on and current is flowing through the primary winding of T1. Once the integrated controller within U1 switches off the MOSFET, the voltages across the windings of T1 reverse, D4 and D5 are forward biased, and secondary winding current flows into output capacitors C4 and C5.

Resistor divider R3 and R4 sense the 5 V output. The controller within U1 uses the current into the FEEDBACK (FB) pin to control MOSFET switching and regulate the 5 V output. The turns ratio between the 5 V and the 18 V windings provides adequate regulation of the 18 V output. An LC post filter (L1 and C6) on the 5 V output attenuates the switching ripple to <100 mV pk-pk.

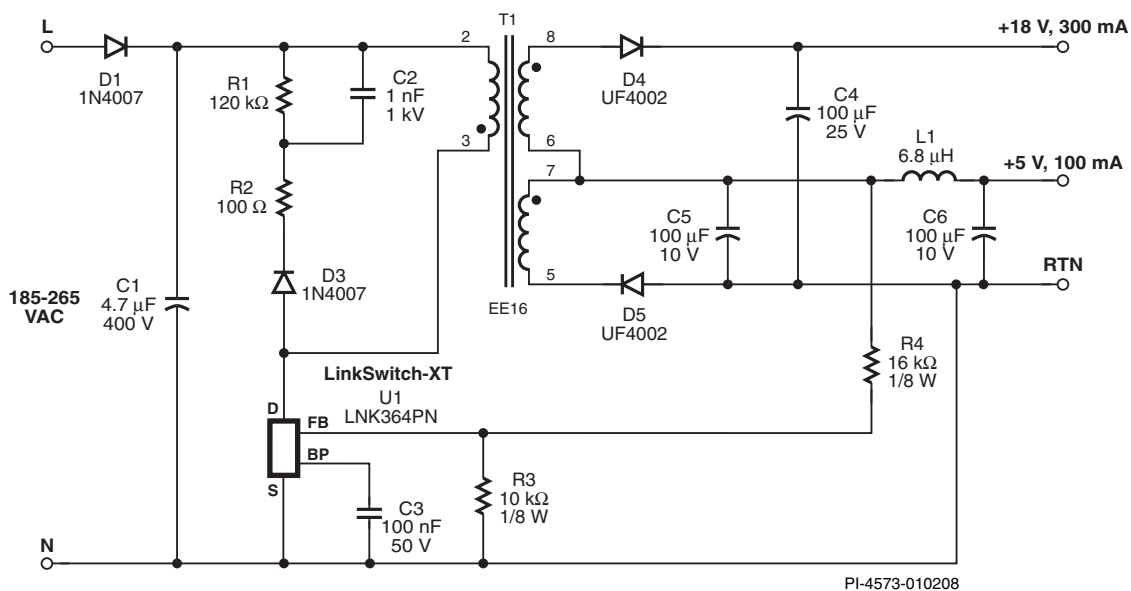

Figure 1. LinkSwitch-XT, 5.9 W Induction Cooktop, Auxiliary Power Supply.

Key Design Points

- Wind T1 for the lowest leakage inductance by choosing wire gauge sizes that completely fill each winding layer.
- The PI Xls spreadsheet tool can be used to modify this supply to allow operation over the universal AC input voltage range (85 – 265 VAC).

- Select the values of R3 and R4 so that when the 5 V output is in regulation, there is 1.63 V on the FB pin, with a current of 49 μ A flowing into the FB pin. Higher ohmic values for R3 and R4 will not improve efficiency and may degrade regulation accuracy.
- Feedback resistor R4 must be connected before the LC post (L1 and C6) filter in order to avoid groups of enabled and disabled switching cycles from occurring.

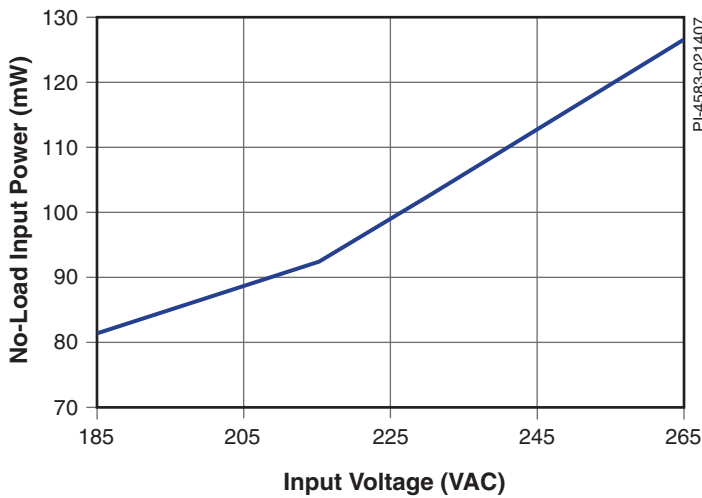

Figure 2. No-Load Input Power vs. Line Voltage.

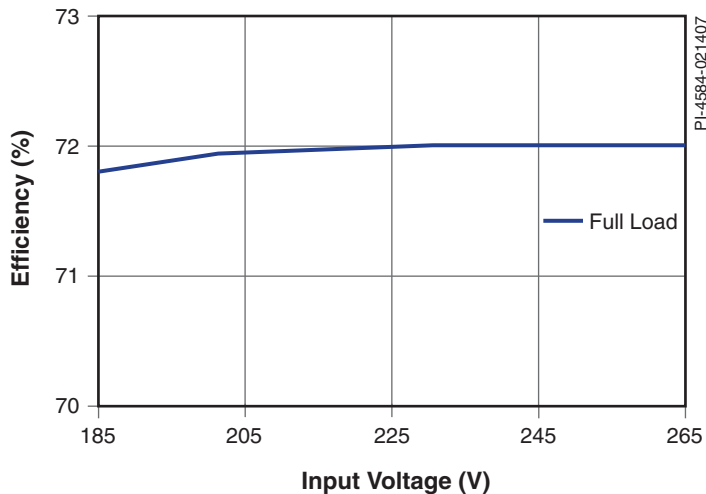

Figure 3. Efficiency vs. Input Voltage at Full Load.

Loading	5 V Output	18 V Output
100% on 5 V and 100% on 18 V	4.94	18.14
100% on 5 V and 10% on 18 V	5.01	19.46
10% on 5 V and 100% on 18 V	5.08	17.99
10% on 5 V and 10% on 18 V	5.14	18.51

Table 1. Output Cross Regulation at 265 VAC.

Transformer Parameters

Core Material	EE16 NC-2H or equivalent, gapped for A_{Lg} of 63 nH/t ²
Bobbin	EE16, 8 pin
Winding Details	Primary: 200T, 36 AWG, tape Secondary: 5 V, 11T, 29 AWG triple insulated, tape Secondary: 18 V: 26T, 30 AWG triple insulated, tape
Primary Inductance	2.77 mH, $\pm 10\%$
Primary Resonant Frequency	500 kHz (minimum)
Leakage Inductance	111 μ H (maximum)

Table 2. Transformer Parameters. (AWG = American Wire Gauge, TIW = Triple Insulated Wire)

Power Integrations
5245 Hellyer Avenue
San Jose, CA 95138, USA.
Main: +1 408-414-9200
Customer Service
Phone: +1-408-414-9665
Fax: +1-408-414-9765
Email: usasales@powerint.com

On the Web
www.powerint.com

Power Integrations reserves the right to make changes to its products at any time to improve reliability or manufacturability. Power Integrations does not assume any liability arising from the use of any device or circuit described herein. POWER INTEGRATIONS MAKES NO WARRANTY HEREIN AND SPECIFICALLY DISCLAIMS ALL WARRANTIES INCLUDING, WITHOUT LIMITATION, THE IMPLIED WARRANTIES OF MERCHANTABILITY, FITNESS FOR A PARTICULAR PURPOSE, AND NON-INFRINGEMENT OF THIRD PARTY RIGHTS. The products and applications illustrated herein (transformer construction and circuits external to the products) may be covered by one or more U.S. and foreign patents or potentially by pending U.S. and foreign patent applications assigned to Power Integrations. A complete list of Power Integrations' patents may be found at www.powerint.com. Power Integrations grants its customers a license under certain patent rights as set forth at <http://www.powerint.com/ip.htm>.

The PI logo, TOPSwitch, TinySwitch, LinkSwitch, DPA-Switch, PeakSwitch, EcoSmart, Clampless, E-Shield, Filterfuse, StackFET, PI Expert and PI FACTS are trademarks of Power Integrations, Inc. Other trademarks are property of their respective companies. ©2007, Power Integrations, Inc.